

Seismic Experiments on the Fracturing and Overturning of Columns.

BY

F. OMORI, D. Sc.,

Member of the Earthquake Investigation Committee.

I. INTRODUCTION.

1. *Object of the experiments.*—For the application of seismology to construction in earthquake countries, it is necessary, besides the observation of the damage due to actual earthquakes, to investigate experimentally the effects of artificial seismic movements on various models of construction, the ultimate object being the calculation of the seismic stability of given structures.

We must naturally begin with the simplest structures. Thus, for instance, in the case of a building, it would be convenient to investigate separately its parts or elements, such as columns, walls, arches, roofs, vaults, etc. In the present paper, which is to be regarded only as a preliminary report, I give the results of experiments on the fracturing and overturning of brick and other columns, carried on in the Tokyo Imperial University between March 1898 and March 1899.

The effects of earthquakes on buildings and works of construction are generally of a complex nature, but may conveniently be divided into two elementary phenomena—fracturing and overturning. The present experiments have accordingly been conducted in these two divisions.

2. *The shaking table.*—Artificial earthquake motion was produced by a *shaking table*,* which consisted of a stout wooden floor properly

* Designed by Professors Mano and Inokuchi.

mounted on strong supports, and which could be made to move with independent horizontal and vertical simple harmonic motions by means of steam engines. As the maximum ranges of motion of the table amounted to 150 and 90 mm. respectively in the horizontal and the vertical directions, and as the period* could be made as small as 0,2 second, movements much greater than those which took place at Nagoya or Gifu on the occasion of the great Mino-Owari earthquake of Oct. 28th, 1891, could easily be produced. (Fig. 1.)

The shaking table is described by Prof. Mano elsewhere in these volumes.

3. *The vertical motion.*—In ordinary cases, the vertical component of earthquake motion is much smaller than the horizontal. Thus, in the severe Tokyo earthquake of June 20th, 1894, the strong-motion seismograph in the Seismological Institute recorded a maximum horizontal motion of 73 mm. (period 1,8 seconds), while the maximum vertical motion was only 11 mm. In this case, therefore, the damage was essentially due to the horizontal motion, and generally the non-synchronizing in horizontal motion of the walls and roof is doubtless the principal cause of the destruction of brick buildings. Vertical motion, even when very great, seems unable by itself to produce any great damage. Referring to actual instances, we find that one-storied brick buildings are most damaged at the junction of the walls with the roof, and that two-storied ones are similarly most damaged at the junction of the upper walls with the roof, while the lower walls remain uninjured or very little affected. Hence, with respect to the destructive power of the earthquake motion, the vertical component is only of a secondary importance in comparison with the horizontal; in other words, the damage of brick structures may, excepting in cases

* The *period* in this paper always means the *complete period*.

of foundation sinking, be regarded as due to the horizontal motion. From these reasons, as well as for the sake of simplicity, I have limited myself in the present course of experiments to the consideration of the destructive effects of the horizontal motion.

I may here note that earthquake motion, though sometimes very violent, is continuous and does not consist of isolated jerks or shocks. The idea prevalent among certain engineers that in destructive earthquakes buildings are first uplifted by the vertical motion and then destroyed by being suddenly thrown downwards, is quite erroneous.

4. *The intensity of motion in destructive earthquakes.*—The maximum acceleration of the earth-particles in the Tokyo earthquake of 1894 was, calculating from the values of the range of motion and the period given in § 3, found to be 444 mm. per sec. per sec. In the great Mino-Owari earthquake of 1891, the maximum acceleration and range of motion at Nagoya were respectively 2600 mm. per sec. per sec. and about 233 mm., the corresponding quantities at Gifu and many other places in the meizoseismal area being still greater.*

The motion of the shaking table varied in the present experiments between 30 mm. and 112 mm., its range being thus comparable to that of strong and destructive earthquakes.

5. *Literature.*—The only work of reference is that written by Prof. J. Milne and myself, published in Vol. I of the Seismological Journal of Japan (1892), giving an account of experiment on the fracturing and overturning of columns by horizontally applied motion carried on in 1891 in the Work-shop of the Engineering College of Tokyo Imperial University. The method of experiment then adopted was nearly similar to that in the present instance.

* See the present author's Note on the Mino-Owari Earthquake of 1891.

II. FRACTURING OF BRICK COLUMNS.

6. *Method of experiment.*—The brick column was firmly fixed to the shaking table and then fractured by giving proper movements to the latter. By the arrangement described in § 7, the motion of the shaking table was mechanically registered in the form of a diagram, while the fracture of the column was carefully watched and its exact moment electrically recorded. The intensity of the motion, which caused the fracture was then calculated from the diagram and compared with the theoretical value of the seismic stability of the column.

7. *Diagram of motion of the shaking table.* (Fig. 2.)—For recording the motion of the shaking table, a pointer *b* is fixed to the latter at *a* and carries a steel pen hinged at its end. This pen writes in ink the motion of the table in its natural size on the white paper *c*, which is wrapped round two parallel cylindrical tubes *e*, whose axes are screw-cut, and which are turned by the clock-work *d*, the paper being displaced transversely 1 cm. per revolution.*

For gauging exactly the motion of the paper *c*, time ticks are marked by means of a small pendulum *f*, 148 mm. long (Fig. 3), which allows an electric current to pass through the coil *h* (Fig. 2) each time its index crosses the mercury pool *g*. The complete period of vibration of the pendulum was 0,77 sec.

The moment of fracture of the brick column was signalled by pressing a key, which caused an electric current to pass through the coil *i* (Fig. 2).

The amplitude and period of the shaking table which caused the fracture of the brick columns, can thus be exactly measured from the diagram. In a few cases the movements of the tops of these columns have likewise been recorded. For illustrations, see figs. 8-15.

* This record-receiver forms part of Professor Tanakadate's Seismograph.

8. *The brick columns.* (See Figs. 4 and 5.)—Twenty-four brick columns, numbered from 1 to 24, were used in the experiments, their details being given in table I. As, however, some of the columns were used several times over, the total number of the fracturing experiments amounted to forty-four. The columns were constructed between March 20th and May 22nd, 1898, and the fracturing experiments were carried on between Oct. 12th, 1898, and Feb. 15th, 1899.

The three columns Nos. 22, 23 and 24, were composed of ordinary bricks, while all the rest were composed of specially made small bricks. Thus the nine columns Nos. 1 to 9, and the remaining twelve Nos. 10 to 21, were composed of bricks, whose linear dimensions were respectively one-fifth, and one-half of that of the ordinary bricks.

The largest columns were Nos. 16-24, whose heights varied between 1580 and 1810 mm., and whose sectional areas between $\overline{230}^2$ and $\overline{233}^2$ sq. mm. Nos. 19, 20 and 21, were hollow, all the others being solid. As in experiments of this nature it is absolutely necessary that the bodies should be uniform in tensile strength, each column was constructed of bricks of one and the same quality.

TABLE I.—BRICK COLUMNS USED IN THE FRACTURING EXPERIMENTS

2 x = thickness of column ; 2 y = height of column.

No.	2 x. mm.	Sectional area. (sq. mm.)	2y. (mm.)	Remarks.	Quality of brick.	Date of construc- tion of the column.
1	96	96 × 120	720	½-bricks, 50 layers.	Ordinary 1st class.	April 6th, 1898.
2	"	"	"	" " " "		May 21st, 1898.
3	"	"	"	Same as Nos. 1 and 2, furnished with a concrete base box.		
4	97	$\frac{97^2}{2}$	730	½-bricks, 50 layers.	"	May 16th, 1898.
5	"	"	"	" " " "		May 21st, 1898.
6	"	"	"	Same as Nos. 4 and 5, furnished with a concrete base box.		
7	72	97 × 72	720	½-bricks, 50 layers.	"	May 19th, 1898.
8	"	"	"	" " " "		May 21st, 1898.
9	"	"	"	Same as Nos. 7 and 8, furnished with a concrete base box.		
10	111	$\frac{111^2}{2}$	902	½-bricks, 25 layers.	Ordinary 2nd class.	March 26th, 1898.
11	"	"	"	" " " "		"
12	110	$\frac{110^2}{2}$	915	Same as Nos. 10 and 11, furnished with a concrete base box (240 × 240 × 145).		April 2nd, 1898.
13	110	110 × 232	1800	½-bricks, 50 layers.	"	March 31st, 1898.
14	"	"	"	" " " "		"
15	"	"	"	Same as Nos. 13 and 14, furnished with a concrete base box (330 × 460 × 180).		"
16	230	$\frac{230^2}{2}$	1744	½-bricks, 50 layers.	"	March 20th, 1898.
17	"	"	"	" " " "		"
18	"	"	"	" " " "		"
19*	233	$\frac{233-131}{2}$	1810	½-bricks, 50 layers ; hollow.	"	March 24th, 1898.
20*	"	"	"	" " " "		March 31st, 1898.
21*	"	"	"	Same as Nos. 19* and 20*, furnished with a concrete box (460 × 460 × 180).		
22	230	$\frac{230^2}{2}$	1580	Ordinary bricks, 23 layers.	Extra 2nd class.	April 3rd, 1898.
23	"	"	"	" " " "	"	"
24	220	$\frac{220^2}{2}$	1587	Same as Nos. 22 and 23, furnished with a concrete base box (460 × 460 × 280).	Extra 1st class.	May 22nd, 1898.

* Those marked with asterisks (*) are hollow columns, the inner side being = 131 mm.

For all the columns one and the same mortar, consisting of one part of cement and two parts of sand, was employed, the tensile strength, as shown in table II, being generally high. The object of the use of such a good mortar in the fracturing experiments was to avoid as far as possible, discordance in the results. If the mortar had been of a bad quality, the strength of the column might very easily have been modified by the non-uniformity of the joints, thereby rendering difficult the comparison of experiment and theory.

The small bricks used in columns Nos. 1-21 were inferior in quality, being of the kinds known as *ordinary first* and *ordinary second class* bricks. For our experiments, however, this circumstance was quite favourable, since the tensile strength of the mortar in these columns was nearly equal to that of the bricks themselves, so that the breaking of a brick column, which usually took place at a joint, was rarely caused by the clean separation of mortar and bricks, the fracture, in the majority of cases, occurring through the mortar and the brick. Such columns may therefore be regarded as having nearly a uniform tensile strength throughout.

As remarked in § 12, the tensile strength of the mortar was higher when used with bricks of superior quality than when used with those of inferior quality.

9. *Methods of fixing the columns to the shaking table.*—For fixing the columns to the shaking table, the following two methods have been employed.

(1). (See Fig. 5.) Each of the columns Nos. 3, 6, 9, 12, 15, 21 and 24, had its base embedded in concrete contained in a stout wooden box *a*, which was firmly fixed to the table by means of two strong wooden beams *b*, and of four bolts *c*.

(2). The rest of the columns, which were free and had no concrete

base, were fixed to the table by means of iron frames *a*,* shown in Fig. 6.

10. *Formulae*.—To obtain formulæ by which the seismic stability of brick columns can be calculated, it is necessary to examine the action of earthquake motion on such bodies.

The complete period of the principal vibration of destructive earthquakes is probably one or two seconds, and its range of motion varies from some 50 mm. to upwards of 200 mm.** Consequently a brick column would not be overthrown in a direction opposite to the motion of the ground, unless its height be comparatively very great. In this section, I shall confine myself to the consideration of *short* columns, viz. those whose height is not *infinitely* great in comparison with its thickness and the range of the earthquake motion. In such columns, a centre of percussion does not exist, as will be seen from the following consideration.

Let ABCD be a brick column fixed at AB to the ground. Supposing that the ground is, at a given moment, moving from *a* towards *b*, the acceleration of the earth-motion is zero at the equilibrium position, *o*, and gradually increases to the maximum at the right hand extremity *b*. Thereafter the acceleration decreases and becomes again zero at the equi-

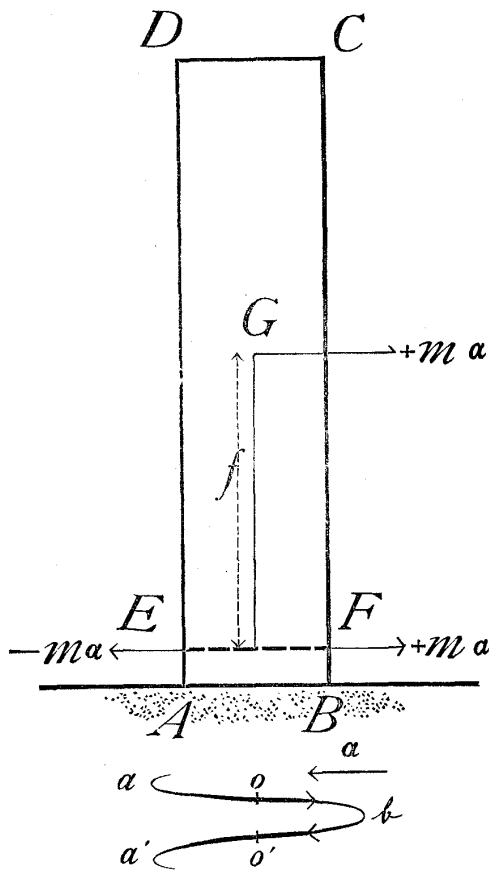

* Designed by Messrs Mano, Inokuchi and Yasunaga.

** See the present Author's Notes on the earthquakes of Tokyo in 1894 and of Mino-Owari in 1891.

librium point o' . (In the figure, the two paths aob and $bo'a'$ have for the sake of clearness been separately drawn. These two are of course one and the same, o' and a' coinciding respectively with o and a .) Now if we impress uniformly to the column and to the ground an acceleration $+a$ equal and opposite to that of the latter, which may be denoted by $-a$ and is directed towards the equilibrium position o , the relative motion of the column with respect to the ground would not be changed. The ground is thereby brought to a state of rest, while the column is impressed with an acceleration $+a$, and therefore may be regarded as acted on by a force equal to the product of its mass and the acceleration of the earthquake motion in the same direction as the actual displacement of the ground. Let us now take any given section EF of the column and consider the action by which the latter may be fractured. The portion $EFCD$ whose weight is W and the height of whose centre of gravity G above the section EF is f , is, according to what has been stated above, acted on by a horizontal force $\frac{aW}{g}$ applied at G . Hence, introducing two equal and opposite forces $+\frac{aW}{g}$ and $-\frac{aW}{g}$ along the line of intersection of the section EF and the principal plane through G , we get a couple producing flexure of the column and having a moment

$$M = \frac{f a W}{g}. \quad (1)$$

The shearing force $+\frac{aW}{g}$ in the plane EF may be neglected in comparison with the bending moment (1), when the height of the column is many times greater than its thickness. If we denote by T the complete period and by a the amplitude, or semi-range, of the earthquake motion, the acceleration a varies between zero and the maximum value $\frac{4\pi^2 a}{T^2}$. I shall hereafter regard the a in equation (1) as denoting the maximum acceleration, and consequently the max-

imum value of M as denoting the fracturing power of the earthquake motion.

Flexure of the column.—Let us assume the column to have a central axis, (pq), that is either to be uniform in section or to be such that the centres of inertia of all the section lie in a straight line. If

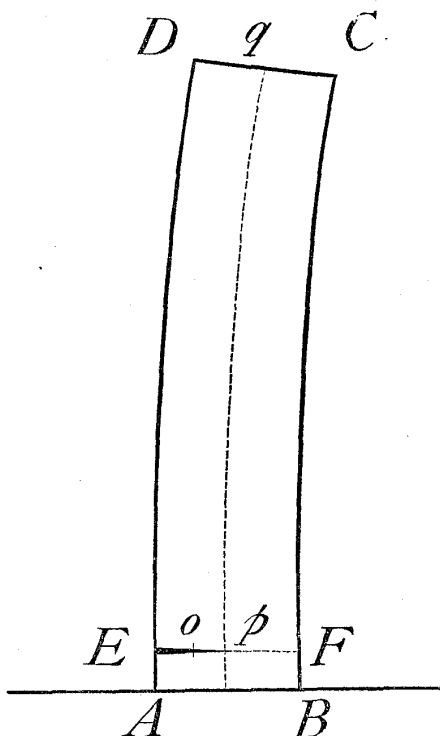

now the column ABCD be slightly deflected by a horizontal force normal to the axis pq , the plane which originally passed through pq and was normal to the direction of the force becomes a *neutral surface*, undergoing curvature only and remaining unchanged in length, while the longitudinal filaments on each side of the surface suffer respectively contraction and elongation. The longitudinal tension (or pressure) P , at any given point o , is given by the following equation:—

$$P = \frac{M}{I} x, \quad (2)$$

in which x is the distance op , I the moment of inertia of the section EF with respect to its line of intersection with the neutral surface, and M the bending moment, which in the case of the earthquake motion is given by equation (1). Substituting the value of M from equation (1), we obtain

$$P = \frac{x f a W}{I g},$$

so that P is proportional to x and its maximum value occurs when $x=x_0$, supposing the thickness of the column $=2x_0$. Thus

$$P(\text{maximum}) = \frac{x_0 f a W}{I g}$$

When P is sufficiently large and equal to F the tensile strength of the column, the latter will be cracked at the side E , and then we obtain

$$F = \frac{f a W x_0}{I g}$$

or

$$a = \frac{I g F}{x_0 f W} = \frac{I g F}{x_0 f w V}, \quad (3)$$

in which V is the volume of the portion fractured and w the weight per unit volume of the column.

Fracture of the column. The *fracture* of the column here means simply the production of cracks at the side E , and hence it is a phenomenon totally different from its *overturning*. Equation (3) gives the acceleration of the earthquake motion capable of fracturing a given brick column.

11. *Remarks on equation (3).*— a denotes the maximum acceleration of the earthquake motion in mm. per second per second. $g=9800$ mm. F is the tensile strength of the column in lbs. per sq. in. w is the weight per unit volume of the column, and is in ordinary cases equal to 0,0603 lb. The remaining quantities, I , x_0 , f and V , are all to be expressed in inches.

I shall next give the values of I in a few common cases.

(a)  Section square ; each side $=2x_0$. $I = \frac{4}{3} x_0^4$

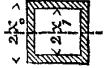
(b)  Section hollow-square ; outer side $=2x_0$,
inner side $=2x_1$. $I = \frac{4}{3} (x_0^4 - x_1^4)$

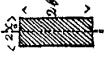
(c)  Section rectangular ; the thickness, or dimension
in direction of the earthquake motion $=2x_0$, and
the other side $=2b$. $I = \frac{4}{3} b x_0^3$.

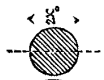
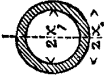
- (d)  Section circular ; diameter = $2x_0$. $I = \frac{\pi x_0^4}{4}$.
- (e)  Section annular ; outer diameter = $2x_0$,
inner diameter = $2x_1$. $I = \frac{\pi(x_0^4 - x_1^4)}{4}$.

Further if the section be uniform, we obtain from (a), (b) and (c) :

$$\text{(Section square)} \quad \alpha = \frac{2gFx_0}{3w \cdot 2f^2} \quad (4)$$

$$\text{(Section hollow-square)} \quad \alpha = \frac{2gF(x_0^2 + x_1^2)}{3x_0 \cdot w \cdot 2f^2} \quad (5)$$

$$\text{(Section rectangular)} \quad \alpha = \frac{2gFx_0}{3w \cdot 2f^2} \quad (6)$$

The columns of square and rectangular sections lead naturally to one and the same result, provided their dimensions in the direction of the earthquake motion be equal to one another. Equations (4) and (5) are the working formulæ in the discussion of the fracturing experiments.

12. *Tensile strength of the brick columns.*—To calculate by equations (3), (4) and (5) the seismic stability of the columns, it is necessary first to find out the value of the tensile strength ; consequently I made a number of experiments by means of a testing machine in the Work-shop of the Engineering College, on the tensile strength of the fragments of the columns used in the fracturing experiments. The results are given in table II.

The pieces of the brick-work tested were cut into ordinary shapes, as shown in the figure, and the stretching load was applied always very gradually. In the table, the time intervals between the first application of the load and the breaking of the test pieces are given only in a few cases as illustrations.

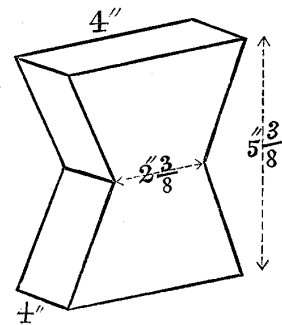

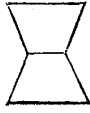
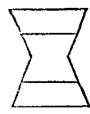
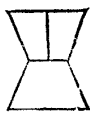

TABLE II.—TENSILE STRENGTH OF THE BRICK COLUMNS.

(a) Columns Nos. 1, 3, 6, 7, 9, 11, 14, 16, 17 and 19.*

No. of Column.	No. of Expt.	Sectional area. (sq. in.)	Tensile strength. (lbs. per sq. in.)	Time interval between the first application of load and the occurrence of fracture.	Date of the testing expt.
1	1	9.38	47.6	...	Dec. 14th, 1898.
	2	"	58.5	...	
	3	"	77.0	...	
	4	"	38.2	...	
	mean		55.3		
3	1	10.3	59.8	^m 1 ^s 13	"
	2	9.4	47.7	0 34	
	3	"	82.3	0 17	
	4	10.3	50.0	0 11	
	5	9.4	35.8	...	
mean		55.1			
6	1	9.4	42.3	0 54	Dec. 16th, 1898.
	2	"	62.6	1 17	
	3	10.3	64.1	1 37	
	4	6.9	10.8	1 57	
	mean		69.3		
7	1	7.56	52.1	...	Dec. 14th, 1898.
	2	8.25	24.4	...	
	3	6.88	52.9	...	
	4	"	48.4	...	
	5	7.56	41.4	...	
mean		43.8			
9	1	6.9	47.2	0 52	Dec. 16th, 1898.
	2	"	53.7	...	
	3	"	71.6	1 24	
	4	"	62.6	...	
	5	8.3	58.3	1 16	
mean		58.8			

No. of Column.	No. of Expt.	Sectional area. (sq. in.)	Tensile strength. (lbs. per sq. in.)	Time interval between the first application of load and the occurrence of fracture.	Date of the testing expt.
11	1	10.6	21.6	m s 0 9	Dec. 14th, 1898.
	2	"	30.3	0 15	
	3	"	44.9	0 41	
	4	"	88.7	...	
	5	"	49.1	1 10	
	mean		53.3		
14	1	10.0	36.4	0 55	"
	2	"	38.6	0 39	
	3	13.0	32.4	0 22	
	4	10.0	34.7	0 31	
	5	"	36.4	0 46	
	mean		33.7		
16	1	10.0	53.2	...	"
	2	"	58.8	1 14	
	3	"	47.0	...	
	4	"	63.2	0 44	
	5	12.0	34.0	...	
	mean		51.2		
17	1	10.0	29.1	0 42	Dec. 16th, 1898.
	2	"	61.6	1 34	
	3	"	36.9	0 37	
	4	"	19.6	0 9	
	5	12.0	40.1	1 4	
	6	10.0	60.4	0 20	
	mean		41.3		
19*	1	5.0	84.0	...	Dec. 14th, 1898.
	2	"	45.9	...	
	3	"	50.9	...	
	4	"	39.2	...	
	5	"	101.	...	
	mean		64.2		

(b) Column No. 23.

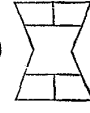
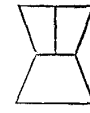
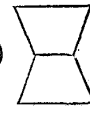
Form of the brick-work test piece.	No. of expt.	Sectional area. (sq. in.)	Tensile strength. (lbs. persq. in.)	Time interval between the first application of load and the moment of fracture.	Date of the testing expt.	Date of the construction of the column.	Remarks.
(A) 	1	9.69	65.3	m s 1 37	Feb. 4th, 1899.	May 22nd, 1898.	Separated at the joint.
	2	"	43.5	35			"
	3	"	76.2	1 27			"
	4	"	93.9	1 8			"
	mean.....	69.7					
(B) 	1	10.0	143.6	2 15	"		Broke through brick at the section of minimum area.
	2	"	163.7	"			"
	3	"	169.5	—			"
	4	"	149.4	1 38			"
	mean.....	156.6					
(C) 	1	9.69	108.9	1 59	"		Separated at the joint of the minimum section.
	2	"	92.8	1 34			"
	3	"	141.4	—			"
	4	"	153.4	2 55			"
	mean.....	124.1					
(D) 	1	9.69	149.6	—	"		Broke through brick at the section of minimum area.
	2	"	142.7	1 37			"
	mean.....	146.2					
(E) 	1	10.0	122.7	1 31	"		"
	2	11.0	127.7	1 48			"
	mean.....	125.2					
(F) 	1	9.51	51.3	—	Feb. 26th, 1899.		Separated cleanly at the joint.
	2	9.46	32.5	—			"
	mean.....	41.9					
(G) 	1	9.51	29.9	—	"		"
	2	9.42	36.7	—			"
	mean.....	33.3					

The mean deduced from (B), (D) and (E), which gives the tensile strength of the bricks, is 142 lbs. per sq. in., while that deduced from (A), (C), (F) and (G), which gives the strength of the mortar and brick joint, is 77.1 lbs. per sq. in. The mean value of 37.6 lbs. per sq. in., obtained from (F) and (G), is to be regarded as representing the weakest strength of the column.

The value of 53.6 lbs. per sq. in., meaned from (A), (F) and (G), is to be used for the columns, Nos. 23 and 23'.

(c) Column No. 18.

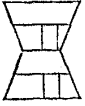
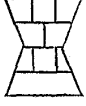
Form of the brick-work test piece.	No. of expt.	Sectional area. (sq. in.)	Tensile strength. (lbs. per sq. in.)	Form of the brick-work test piece.	No. of expt.	Sectional area. (sq. in.)	Tensile strength. (lbs. per sq. in.)
(A) 	1	10.9	38.6	(B) 	1	9.27	42.4
	2	9.62	50.2		2	9.61	52.4
	3	12.1	30.3		3	10.9	39.0
	4	9.2	67.8		4	Simply dropped apart during fixing	0
	5	9.2	42.3		5	9.28	36.9
	6	10.1	69.6		6	9.35	44.0
	7	9.47	56.5		7	9.35	61.6
	8	9.29	22.8		8	9.41	30.9
	9	9.34	27.9		9	9.50	60.1
	10	11.3	38.6		10	9.41	20.7
		mean...	44.5			mean...	43.1

General mean = 43.8 lbs. per sq. in.

The date of construction of the column was March 20th, 1898; and that of the testing experiments Feb. 21st, 1899. The test pieces were fractured in general, partly through brick and mortar and partly by the separation of these two substances.

(d) Column No. 13.

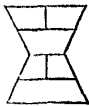
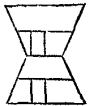
Form of the brick-work test piece.	No. of expt.	Sectional area. (sq. in.)	Tensile strength. (lbs. per sq. in.)	Form of the brick-work test piece.	No. of expt.	Sectional area. (sq. in.)	Tensile strength. (lbs. per sq. in.)
(A) 	1	9.27	17.6	(B) 	1	9.46	13.1
	2	9.61	57.5		2	10.0	55.5
	3	9.51	54.1		3	9.57	24.9
	4	11.9	29.9		4	9.87	25.2
	5	Simply dropped apart during fixing.	0.		5	11.4	35.5
	6	9.46	13.1		6	9.27	46.5
	7	9.77	34.6		7	9.46	30.6
					8	9.61	42.1
		mean...	34.4		mean...	34.1	

General mean = 34.2 lbs. per sq. in.

The date of construction was March 20th, 1898 ; and that of the testing experiment Feb. 26th, 1899. The brick pieces were fractured, in general, partly through brick and mortar and partly by the separation of these two substances.

The mean deduced from the eight smallest values of the tensile strength is 19.3 lbs. per sq. in., which is to be used for the calculation of the seismic stability of the column No. 13.

(e) Column No. 20.*

No. of expt.	Sectional area. (sq. in.)	Tensile strength. (lbs. per sq. in.)	No. of expt.	Sectional area. (sq. in.)	Tensile strength. (lbs. per sq. in.)
1	5.55	65.1	6	5.01	62.9
2	4.94	47.6	7	4.84	35.9
3	5.09	67.9	8	5.00	62.2
4	6.18	38.2	9	5.00	84.6
5	5.10	48.4	10	5.10	66.5

General average = 57.9 lbs. per sq. in.

The date of construction of the column was March 24th, 1898; and that of the testing experiments March 10th, 1899.

The form of the brick-work test pieces was as shown in the figure.



In the testing experiments, the load or stretching weight was applied always very gradually.

(f) Columns Nos. 10, 12 and 15.

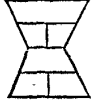
No. of column, and the form of the brick-work test piece.	No. of expt.	Sectional area. (sq. in.)	Tensile Strength. (lbs. per sq. in.)	Date of construction of the column.	Remarks.
No. 10. 	1	9.44	52.2	March 26th, 1898.	Broke through brick and mortar.
	2	10.4	76.5		Broke through brick.
	3	8.90	38.0		Partly broke through brick and partly separated at the joint.
	mean....		55.6		

Tensile strength meaned from (1) and (3) = 45.1 lbs. per sq. in. This is to be used for the calculation of the stability of the column.

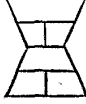
No. 12. 	1	10.5	77.4	April 2nd, 1898.	Broke through brick.
	2	9.22	28.5		Separated cleanly at the joint.
	3	"	31.9		Separated at the joint, a portion of the mortar being also broken.
	4	"	34.0		Separated at the joint, a portion of the brick face being scratched off.
	5	"	39.0		Separated cleanly at the joint.
	mean....		42.2		

Tensile strength meaned from (2) (5) = 33.4 lbs. per sq. in. This is to be used for the calculation of the stability of the column.

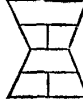
No. 15. (A) 	1	8.81	47.8	March 31st, 1898.	Separated at the joint, a portion of the brick face being scratched off.	
	2	9.79	39.0		Partly broke through mortar and partly separated at the joint.	
	3	10.4	38.2		Broke through brick.	
	4	9.44	70.2		"	
	5	9.60	54.5		"	
	mean....		49.9			
	(B) 	1	9.44		63.2	Broke through brick.
		2	10.6		17.0	Separated cleanly at the joint.
		3	9.79		52.8	" "
		4	9.44		39.8	Partly broke through brick and partly separated at the joint.
5		9.79	32.2	Separated cleanly at the joint.		
6		7.42	39.5	" "		
7		7.42	31.2	" "		
8		—	0	Simply dropped apart.		
mean....		39.4				
mean of (A) and (B).....		44.7				

Tensile strength, meaned from (A) 1 and (B) 2, 3, 5, 6, 7, 8 = 30.2 lbs. per sq. in. This is to be used in the calculation of the stability of the column No. 15."

(g) Column No. 21.*

Date of expt.	No. of expt.	Sectional area. (sq. in.)	Tensile strength (lbs. per sq. in.)	Date of expt.	No. of expt.	Sectional area. (sq. in.)	Tensile strength, (lbs. per sq. in.)	Remarks.
March 8th, 1899.	1	5.12	65.1	April 5th, 1899.	11	5.04	56.2	Separated at the joint.
	2	4.93	41.8		12	4.75	82.1	Broke through bricks.
	3	4.74	30.4		13	6.50	55.1	Separated at the joint.
	4	5.00	12.2		14	4.75	51.8	..
	5	5.27	61.5		15	5.30	64.5	Broke through bricks.
	6	5.09	31.8		16	4.75	49.3	Separated at the joint.
	7	..	57.4		17	5.03	81.9	Broke through bricks.
	8	5.01	26.7		18	—	0	Simply dropped apart.
	9	5.09	49.2		19	4.75	32.4	Separated cleanly at the joint.
	10	5.14	50.2		20	..	28.9	..
					21	..	38.8	Separated at the joint.



The average tensile strength = 46.1 lbs. per sq. in., which value is to be used for the calculation of the stability of the column No. 21.* The 11 least among the above 21 determinations of the tensile strength, however, give an average value of 31.3 lbs. per sq. in., which is to be used in the calculation of the column No. 21.*

The form of the brick-work test piece was as shown in the figure.



In the testing experiments, the load or stretching weight was applied always very gradually.

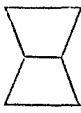

(h) Column No. 22.

Form of the brick-work test piece.	No. of expt.	Sectional area. (sq. in.)	Tensile strength. (lbs. per sq. in.)	Remarks.
(A) 	1	9.05	149	Broke through mortar.
	2	9.04	113	"
	3	9.04	111	Separated at the joint, a portion of the brick face being scratched off.
	4	9.44	125	Broke through mortar, partly also through brick.
	5	9.04	160	" "
	6	—	0	Simply dropped apart during the fixing.
	7	9.09	142	Broke through mortar.
	8	8.69	48.2	Separated cleanly at the joint.
	9	9.26	137	Broke through mortar.
	10	8.93	58.7	Separated at the joint.
	11	9.26	34.5	Separated cleanly at the joint.
	12	9.15	75.8	Separated at the joint.
	13	8.96	153	Broke through mortar.
		mean	100.6	
(B) 	1	8.90	115	Broke through mortar.
	2	"	152	Partly broke through mortar and partly separated at the joint.
	3	"	123	Broke through mortar, a portion of the brick face being scratched off.
	4	"	156	Broke through mortar.
	5	"	107	"
	6	8.96	115	"
	7	9.30	44.0	Separated cleanly at the joint.
	8	"	55.3	Separated at the joint.
	9	9.09	82.2	Separated at the joint, a portion of mortar being also broken.
	10	"	48.4	Separated cleanly at the joint.
	11	8.81	126	Broke through mortar.
	12	9.09	81.6	Separated cleanly at the joint.
		mean	100.4	

The general average value of the tensile strength = 100.5 lbs. per sq. in. The date of construction of the column is April 3rd, 1898; and that of the testing experiments March 28th and 30th, 1899.

In the testing experiments, the load or stretching weight was applied always very gradually.

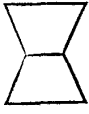
(i) Column No. 24.

Form of the brick-work test piece	No. of expt	Sectional area. (sq. in.)	Tensile strength. (lbs. per sq. in.)	Remarks.
(A) 	1	9.2	209.	Separated at the joint, the brick face being almost entirely scratched off.
	2	9.46	61.	Separated at the joint, half of the brick face being scratched off.
	3	9.29	119.	Separated at the joint, about two-thirds of the brick face being scratched off.
	4	9.31	145.	Separated at the joint.
	5	9.75	78.	Separated cleanly at the joint.
	6	9.26	132.	Separated at the joint.
	7	"	132.	"
	8	9.47	114.	"
	9	9.26	28.8	Separated cleanly at the joint.
	10	9.20	195.	Separated at the joint, the entire brick face being scratched off.
	11	9.20	208.	"
	12	9.29	125.	Separated at the joint, a portion of the brick face being scratched off.
		mean...	128.9	
(B) 	1	9.29	160.	Broke partly through brick.
	2	9.12	233.	Broke through mortar.
	3	9.62	147.	Separated at the joint.
	4	9.62	96.	Broke through mortar.
	5	9.71	202.	Broke through brick.
	6	9.47	145.	Separated at the joint.
	7	"	107.	Separated cleanly at the joint.
	8	8.99	47.3	"
	9	11.2	128.	Broke through brick.
	10	9.20	138.	Broke through mortar.
	11	9.5	45.0	Separated at the joint.
	12	9.05	135.	"
		mean ..	131.9	

General mean = 130.4 lbs. per sq. in.

The date of construction of the column was May 22nd, 1898; and that of the testing experiments Feb. 6th, 1899.

In the testing experiments, the load or stretching weight was applied always very gradually.

According to table II, the tensile strength of the brick columns used in the fracturing experiments varied between 33.7 and 130.4 lbs. per square inch, which wide difference perhaps depends to a certain extent on the quality of the bricks, all the columns having been constructed with the same mortar. The tensile strength of the five columns Nos. 1, 3, 6, 7 and 9, which were composed of $\frac{1}{8}$ -bricks, varied between 43.8 and 69.3 lbs. per sq. in., the average value being 56.5 lbs. per sq. in. Again, the strength of the twelve columns Nos. 10, 11, 12, 13, 14, 15, 16, 17, 18, 19, 20 and 21, which were composed of $\frac{1}{2}$ -bricks, varied between 33.7 and 64.2 lbs. per sq. in., the average value being 47.1 lbs. per sq. in. These $\frac{1}{8}$ and $\frac{1}{2}$ bricks were of the *ordinary first or second class* quality.

The tensile strength of the two columns Nos. 22 and 23, composed of ordinary second class bricks of normal dimensions, were respectively 100.5 and 77.1 lbs. per sq. in.; while that of column No. 24, composed of normal bricks of an extra-superior quality, was 130.4 lbs. per sq. in. These results seem to show that the tensile strength of the brick and mortar joint is raised with the good quality of bricks. I may here add that the tensile strength of the *bricks*, which composed columns Nos. 23 and 24, were respectively 142 and 303 lbs. per sq. in.

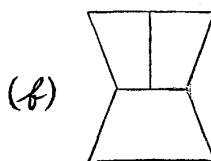
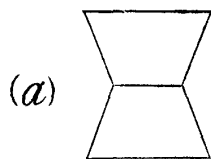

The tensile strength of the brick work seems, so far as the above figures show, to depend little on the size of the bricks themselves, there being for instance no great difference between the strength of the columns composed of $\frac{1}{8}$ -bricks and those composed of $\frac{1}{2}$ -bricks. Again, the brick work of the two columns Nos. 22 and 24 was tested in the two different forms, (a) and (b); (a) having only one horizontal joint and (b) one horizontal and one ver-

tical joint. The two series of determinations however, gave practically identical results. (See table II, h, i.)

13. *Dependence of the tensile strength on the workmanship.*—The tensile strength of the brick and mortar joint for different portions of one and the same column varies sometimes within wide limits. Thus, even excluding the cases in which the test pieces simply gave way while being fixed to the testing machine, the maximum value of the strength amounted sometimes to five or six times its minimum value. (See table II.) This fact is probably to be attributed to the non-uniformity of the workmanship. Fig. 7 illustrates the broken faces of three test pieces taken from the column No. 24, the fracture having been caused in each case by the separation of mortar and brick. The relative strengths of the joints may be judged by the extent of the area of the mortar on which thin layers of the bricks were left adhering, and which in the first case covered nearly the whole face of the separated brick, in the second about one half, and in the third was limited to a few detached points. The tensile strengths for these three cases were, in correspondence with the above facts, respectively 209, 119 and 61 lbs. per sq. in. The importance of a strict superintendence in the construction of the brick-work can not be over-estimated.

14. *Impulse.*—An *impulse* is an action in which the force is applied to a body during an infinitely short interval of time. As the breaking strength of a given body would be different when the force is impulsively applied from what it would be if the force were gradually applied, it is necessary to determine whether the earthquake motion is, in the calculation of the seismic stability of brick columns, to be regarded as an impulse or not. For this purpose let us first examine the relation between an impulse and the strain produced by it. The



well-known proposition, that a force when impulsively applied to an elastic body produces a strain double that caused by the same force when gradually applied, may be explained as follows. Let A diagrammatically represent the position of equilibrium of a given body in its natural state, and O that assumed by it when acted on gradually by a force R. If now the force R act on the body impulsively, the result would be the same as if the body, whose position of equilibrium is at O, had been displaced to A. Consequently the body would be carried to the position A' at an equal distance on the opposite side of the equilibrium position *o* and thus vibrations would be set up. In other words, the strain produced by the impulsive application of the force R is double that produced by its gradual application.

In discussing the effect of a force on a work of construction, difficulty may occur in deciding whether the application of the force is to be regarded as *impulsive* or as *gradual*. The criterion is easily afforded by the above theorem, as follows.

1. If the application of a force to an elastic body be so slow that the latter assumes the position of equilibrium without being thrown into vibrations, the force may be regarded as acting *gradually*.

2. If the application of a force to an elastic body be so rapid that it is finished in a time interval infinitely small in comparison to the period of the corresponding natural vibration of the body, the force may be regarded as acting *impulsively*.

Fracturing by impulse.—What was stated above relates to the behaviour of an elastic body within the limit of its perfect elasticity. With regard to stones and bricks, however, the stress and strain relation is such that fracture immediately takes place when the limit of

elasticity is exceeded ; and consequently we may assume that the strength of a brick column against a force applied impulsively is half that against the same force applied gradually.

15. *The earthquake motion.*—In the application of equation (3) to the calculation of the seismic stability of a brick column,* the quantity a , or the destructive power of the earthquake motion, is, according to the definitions given in § 14, to be regarded as acting *gradually* and not *impulsively* ; that is to say, the quantity F is to be understood as the ordinary tensile strength of the column, and not equal to its half. Thus in the fracturing experiments the period of the shaking table varied, as given in table IV, between 0,23 and 0,89 second and therefore the acceleration of the motion changed from zero to the maximum value in a time interval of 0,06 to 0,22 second. Such a motion, though certainly very violent, can not be considered as producing an impulsive effect to the brick column, the period of whose longitudinal vibration is naturally very short and which is broken by the tension across the plane of fracture produced in consequence of its flexure. The values of the tensile strength obtained by adding the load gradually, given in table II, are therefore to be employed in the calculation, by equation (3), of the seismic stability of the columns.

The above remark respecting the value of F applies also to the case of an actual destructive earthquake, the period of whose principal vibration is probably, as stated in § 10, one or two seconds and therefore longer than those of the shaking table in the present experiments.

16. *Experiments on the tensile strength of bricks.*—In illustration of what was said in § 15, the following experiments have been made.

The tensile strength of a number of bricks of one and the same

* The height of the column must be several times, but not infinitely, greater than its thickness and the range of the earthquake motion.

extra-superior quality was first determined, the result being as shown in the following table :

No. of brick	Sectional area. (sq. in.)	Tensile strength. (lbs. per sq. in.)	Remarks.
1	6.11	316	The load was applied in all the cases very gradually, and the bricks broke at, or near, the smallest section.
2	5.57	337	
3	5.57	365	
4	6.11	262	
5	5.66	241	
6	5.57	350	
7	5.57	237	
8	5.85	356	
9	6.11	257	

Mean.....303.

I may here remark that, in the present experiments, bricks of *extra-superior* quality have been chosen, as such bricks would be comparatively uniform in strength. Having ascertained from the experiments on the bricks, Nos. 1—7, the average value of the tensile strength to be about 300 lbs. per sq. in., the brick No. 8 was fixed to the testing machine and a tension of 200 lbs. per sq. in. was suddenly applied on it by releasing the longer arm of the machine, which had previously been arrested. The brick was, however, not broken. The experiment was then twice repeated with tensions of 227 and 255 lbs. per sq. in. ; still the brick did not give way. When determined by the usual method, the tensile strength of the brick was found to be 356 lbs. per sq. in.

The brick No. 9 was similarly tested by suddenly applying a tension, firstly, of 189 lbs. per sq. in., and secondly, of 217 lbs. per sq. in., but it did not break. The tensile strength was then determined by the usual method and found to be 257 lbs. per sq. in.

In each of these experiments, the application of the load was

certainly finished in a very short interval of time, probably one-tenth of a second or so, still the result shows that the action was not impulsive, the brick remaining unaffected even when acted upon thus suddenly by a tension much greater than half its tensile strength.

17. *Remarks on the tensile strength of the brick columns.*—To determine the approximate values of the tensile strength F , to be used in the calculation of the seismic stability of the brick columns, the following two cases should be considered separately.

(a). When the column was fractured at a joint partly through mortar and brick, and partly by the separation of these two substances, the value of F was obtained by averaging all the determinations of the tensile strength of the brick-work test pieces, which were broken at the joint through the mortar, through the brick, or by the separation of mortar and brick.

(b). When the column was broken at a joint entirely by the separation of brick and mortar, the value of F has been obtained by averaging only those determinations of the tensile strength, in which the brick-work test pieces were broken by the separation of mortar and brick. The ten columns, Nos. 3, 10, 11, 12, 13', 15," 21,* 22', 23 and 23', all belong to this class. For the two columns, Nos. 19* and 19'," which were abnormally weak, the smallest among the different values of their tensile strength have been adopted.

It is unnecessary to remark that the brick-work test pieces gave generally higher values of the tensile strength when the joint gave way by the fracture through mortar or brick than when by the separation of these two substances.

18. *The fracturing experiments.*—The total number of the experiments is forty-three, the condition of the fracture of the columns being described in table III. The specimen diagrams of the motion of the shaking table are given in figs. 8—15.

TABLE III.—FRACTURING EXPERIMENTS.

(a) Columns without Concrete Base.

No.	Total height. (mm.)	Height above the iron fixing frame. mm.	Where and how fractured.
1	720	662	Broke at the 3rd joint, or 64 mm. from base, partly through bricks.
7	"	"	Broke at the base.
8	"	"	" "
9'	720	604	Broke at the base, through bricks.
9"	604	532	Broke, by a clean separation, at the 3rd joint, or 43 mm. from base.
10	902	760	Broke, by a clean separation, at the base.
11	"	720	Broke through joint at the base.
11'	720	650	Not broken.
13	1800	1590	Broke at the 1st joint, or 36 mm. from base, partly through bricks.
13'	1550	1330	Broke at the 1st joint, or 36 mm. from base.
13"	1300	1080	Broke through joint at the base.
13'''	1080	900	" "
13''''	900	720	Broke at the 3rd joint, or 110 mm. from base.
14	1800	1590	Broke at the 4th joint, or 144 mm. from base.
14'	1440	1230	Broke at the 3rd joint, or 110 mm. from base.
14"	1120	940	Broke at the 1st joint, or 36 mm., within the iron fixing frames.
14'''	970	830	Broke at the 4th joint, or 144 mm. from base.
15'	1370	1090	Broke at the 1st joint, or 36 mm. from base, through bricks.
15"	1040	760	Broke through joint at the base.
16	1744	1560	Broke at the 1st joint, or 35 mm. from base.
16'	1560	1360	Broke at the 5th joint, or 170 mm. from base.
17	1744	1530	Broke at the base.
18	"	1570	Broke at the base, partly through bricks.
18'	1570	1400	Broke at the 1st joint, or 35 mm. from base, partly through bricks.
18"	1360	1190	Broke at the 2nd joint, or 70 mm. from base, partly through bricks.
19*	1810	1650	Broke at the base, where small cracks existed beforehand.
19'*	1630	1450	Broke through joint at the base.
19''*	1380	1140	Broke at the 3rd joint, or 109 mm., within the iron fixing frame.
20*	1810	1520	Broke at the 6th joint, or 217 mm. from base, partly through bricks.

No.	Total height. (mm.)	Height above the iron fixing frame. (mm.)	Where and how fractured.
20'*	1270	980	Broke at the 1st joint, or 36 mm. from base, through bricks.
21'*	1450	1160	Broke at the 1st joint, or 36 mm. from base, partly through bricks.
22	1580	1300	Broke at the 1st joint, or 69 mm. from base.
22'	1240	960	Broke through joint at the base.
23	1580	1380	" "
23'	1380	1200	Broke, by a clean separation, at the 2nd joint, or 138 mm. from base.
23"	1100	890	Not broken.
24'	1620	1320	Broke through joint at the base.

(b) Columns with Concrete Base.

No.	Height. (mm.)	Where and how fractured.
3	720	Broke through joint at the base.
6	730	Broke at the 6th joint, or 80 mm. from base, partly through bricks.
9	720	Broke at the base, partly through bricks.
12	915	Broke, by a clean separation, at the 4th joint, or 146 mm. from base.
21*	1810	Broke at the 10th joint, or 340 mm. from base, partly through bricks.
24	1587	Broke at the 1st joint, or 68 mm. from base, within the concrete.

The two columns Nos. 11' and 23'', whose heights were proportionally small, could not be broken even with the strongest motion of the shaking table. All the others were, however, broken near the base; thirty-nine columns giving way at, or very near to, the base while the remaining two Nos. 20* and 21* were broken at one-seventh and one-fifth of their heights from the base respectively. It is thus evident that the columns are seismically weakest at their bases.

As the brick column is fractured always at a joint, its seismic stability may be increased by using a good mortar, until the strength of the joint becomes equal to that of the bricks themselves. It may here be added that the columns composed of $\frac{1}{2}$ - and $\frac{1}{4}$ - bricks of inferior quality were sometimes broken partly by the fracture through brick and mortar and partly by the separation of these two substances, but the other columns, composed of bricks of normal dimensions, were, with the exception No. 24, all broken by a separation of brick and mortar at the joint.

19. *Results of the fracturing experiments.*—The discussion of the results of the fracturing experiments consists in comparing the actual intensity of motion of the shaking table with the calculated values of the seismic stability of the columns.

The intensity, or the maximum acceleration A , of the shaking table may be calculated by the following formula

$$A = \frac{4\pi^2 a}{T^2}, \quad (6)$$

in which a and T are respectively the amplitude (semi-range) and the period of the shaking at the moment when the column was fractured. These two quantities are to be directly measured from the diagrams of the motion of the shaking table obtained by the arrangement described in § 7.

The seismic stability, or the least value of the acceleration α , capable of fracturing the column, may be calculated by means of equation (4) or (5) from its thickness (or dimension in the direction of the earthquake motion), area and form of section, height of centre of gravity of the portion fractured, and the tensile strength of the joint.

It may here be noted that for the calculation the section of fracture of a given column must first be determined. This will in practical cases be easily found. For example a column of uniform section is, as already pointed out, weakest at the base.

The result of the experiments is summarized in table IV.

IV. SUMMARY OF RESULTS OF THE FRACTURING EXPERIMENTS.

$2x$ = thickness of column ; $2y_0$ = its height above the section of fracture ; F = its tensile strength ; and a = acceleration necessary for fracturing the column. (Eq. 4 and 5).

$2a$ = range of motion of the shaking table ; T = period ; and A = maximum acc. or $\frac{4\pi^2 a}{T^2}$.

Date of Expt.	No. of column.	Calculation of a ; eq. 4 or eq. 5.					Motion of the shaking table			Ratio. $\frac{A}{a}$	Date of determination of F.
		$2x$ mm.	$2y_0$ mm.	Sectional area. sq. mm.	F lbs. per sq. in.	a mm./sec. ²	$2a$ mm.	T sec.	A mm./sec. ²		
Oct. 12th, 1898.	1	96	560	96×120	55.3	21200	111.	0.37	16000	0.8	Dec. 14th, 1898.
	7	72	660	72×97	43.8	10100	97.	.57	5900	.6	"
	8	72	"	72×97	"	"	95.	.58	5580	.6	—*
	17	230	1530	$\frac{230}{2}$	41.3	5800	99.	.50	7850	1.3	Dec. 16th, 1898.
	19*	233	1620	$\frac{233}{2} - 131$	cracks beforehand.	—	90.	.81	2710	...	Dec. 14th, 1898.
	19'*	"	1440	"	64.2	13300	107.	.40	13200	1.0	"
	19''*	"	1230	"	39.2	11100	97.	.64	4680	.4	"
	3	96	720	$\frac{120}{2}$	42.9	11000	109.	.52	8000	.7	"
	6	97	650	$\frac{97}{2}$	69.3	22200	69.	.37	9840	.4	Dec. 16th, 1898.
	9	72	720	72×97	58.8	11400	53.5	.70	2170	.2	"
9'	"	604	"	"	16200	70.5	.43	7520	.5	"	
9''	"	490	"	"	24400	76.5	.29	17900	.7	"	
Oct. 26th, 1898.	11	111	720	$\frac{111}{2}$	47.4	12400	43.4	.33	7900	.6	Dec. 14th, 1898.
	11'	"	650	"	53.3	17200	49.	.23	20000	...	"
	23	230	1370	$\frac{230}{2}$	53.6	9850	44.5	.32	not broken 8650	1.0	Feb. 4th and 26th, 1899.
	23'	"	1100	"	"	13900	46.	"	8880	.6	"
	23''	"	894	"	77.2	30200	56.	.23	21300	...	"
	14	232	1440	110×232	33.7	5200	40.	.48	not broken 3430	.7	Dec. 14th, 1893.
	14'	"	1120	"	"	8700	45.4	.32	8780	1.0	"
	14''	110	970	"	"	5500	39.7	.49	3270	.6	"
	14'''	"	680	"	"	11100	107.	.48	8950	.8	"
	16	230	1540	$\frac{230}{2}$	51.2	6900	108.	.51	8200	1.2	"
16'	"	1190	"	"	11600	112.	.35	18000	1.6	"	
Jan. 27th, 1899	18	230	1570	$\frac{230}{2}$	43.8	5600	103.	.62	5960	1.1	Feb. 21st, 1899.
	18'	"	1360	"	"	7400	105.	.50	8300	"	"
	18''	"	1120	"	"	11000	112.	.39	14600	1.3	"
	10	111	760	$\frac{111}{2}$	45.1	11800	103.	.59	5850	.5	March 27th, 1899.

* The tensile strength of col. No. 8 was unfortunately not determined, and consequently the value $F = 43.8$ for col. No. 7 has been adopted in the calculation of a , these two columns being exactly similar to each other.

Date of Expt.	No. of column.	Calculation of a ; eq. 4 or eq. 5.					Motion of the shaking table.			Ratio. A/a	Date of determination of F.
		$2x$ mm.	$2y_0$ mm.	Sectional area. sq. mm.	F lbs. per sq. in.	a mm./sec ²	$2a$ mm.	T sec.	A mm./sec ²		
Feb. 1st, 1899.	12	110	768	$\overline{111}^2$	33.4	8700	47.5	.58	2790	.3	March 27th, 1899.
	13	"	1550	110×230	34.2	2100	46.	.76	1570	.8	Feb. 26th, 1899.
	13'	"	1290	"	19.3	1750	46.5	.72	1790	1.0	"
	13''	"	1080	"	34.2	4400	46.5	"	"	.4	"
	13'''	"	900	"	"	6300	49.7	.42	5570	.9	"
	13''''	"	610	"	"	13800	57.	.29	13400	1.0	"
Feb. 14th, 1899.	21*	233	1470	$\overline{230}^2 - \overline{123}^2$	31.3	5950	111.	.72	4250	.7	March 8th and April 5th, 1899.
	24	220	1620	$\overline{230}^2$	130.4	15100	126.	.46	11800	.8	March 6th and 30th, 1899.
	24'	"	1350	"	"	21500	"	.39	16800	.8	"
Feb. 15th, 1899.	22	230	1240	$\overline{230}^2$	100.5	15300	123.	.44	12600	.8	March 28th and 30th, 1899.
	22'	"	962	"	64.0	13700	128.	.38	17600	1.3	"
	20*	233	1300	$\overline{233}^2 - \overline{133}^2$	57.9	14700	119.	.54	8000	.5	March 10th, 1899.
	20''*	"	944	"	"	27900	123.	.45	11900	.4	"
	21''*	230	1120	$\overline{230}^2 - \overline{123}^2$	46.1	15100	115.	.60	6300	.4	March 8th and April 5th, 1899.
	15'	110	1040	110×232	44.7	4650	109.	.89	2720	.6	March 27th, 1899.
	15''	"	756	"	30.2	10200	118.	.51	8950	.9	"

Mean.....0.8

As will be seen from table IV, the double amplitude of the shaking table varied between 39,7 and 128 mm. and fairly represents the motion likely to occur in strong and destructive earthquakes, the maximum movement in the Tokyo earthquake of June 20th 1894 being, at Hongo, 73 mm. Further, the maximum acceleration varied between 1570 and 21300 mm. per sec. per sec., and therefore it may be regarded as giving the intensity of motion to be expected in any great earthquake. Thus, the maximum acceleration in the low and soft ground portions of Tokyo was at the time of the earthquake just referred to about 1000 mm. per sec. per sec.; while that in the most epifocal tract of the great Mino-Owari earthquake of Oct. 28th 1891 was probably about 10.000 mm. per sec. per sec.

The period of the shaking table varied from 0.23 to 0.89 second.

As columns Nos. 11' and 23'' could not be broken even with the most violent motion of the shaking table, we may reasonably conclude that simple structures, like columns, walls or bridge piers, can when properly constructed resist any destructive earthquake motion.

Considering that experiments of this kind are very difficult to carry on and that the results would sometimes be little more exact than the determination of the order of the quantities concerned, the agreement of the seismic stability (α) of the column with the intensity of motion of the shaking table will be observed, from table IV, to be in general satisfactory. Thus the average ratio of $A : \alpha$ is 0,8, being sufficiently near to unity. The most difficult part in the calculation of α is the determination of F , the different joints of a brick column evidently having not necessarily one and the same tensile strength. As the columns tend to break at the weakest joint

near the base, the values of F employed in the calculations given in table IV are probably somewhat greater than the actual strengths of the fractured joints. Again, it is well known that the tensile strength of the mortar increases with time, the variation continuing sometimes for two or three years. In the present case, the fracturing experiments were carried on 5 to 10 months after the construction of the columns; while the determination of their tensile strength was made from 20 days to 2 months after the fracturing experiments, thus giving values of the strengths possibly a little greater than what we want really to have. The ratio A/a would be brought a little nearer to unity, if properly corrected for these two circumstances each of which tends to increase the value of a .

I conclude therefore that equations (3), (4) and (5) give, without sensible errors, the seismic stability of the columns and walls.

I give next a few remarks respecting equations (3), (4) and (5).

According to equations (4) and (5), the seismic stability (a) of a given uniform column is directly proportional to its thickness ($2x_0$) and inversely proportional to the square of its height ($2f$). It would thus seem that a very tall column is incapable of resisting strong earthquake motion.

Again, according to equation (3), the seismic stability of a uniform column is proportional to its tensile strength F , which latter has however been shown to be practically no other than the strength of the mortar joint. Consequently the stability of such a column can be raised n times by increasing its thickness n times, or by keeping the latter quantity unchanged and increasing the tensile strength of the mortar n times. This conclusion, which applies also to the walls, bridge piers and similar structures, indicates that sometimes both space and expense may be saved by reducing the thickness

of a brick structure and employing a better quality of mortar in its construction.

20.—*Relation between the height of the column and the fracturing acceleration.* In table V, are collected the results of the experiments with columns Nos. 10-15", which were all of one and the same thickness, viz. 110 mm. To reduce all the columns to the hypothetical case of a common tensile strength, say of 100 lbs. per sq. in., the fracturing acceleration (A) was in each case divided by the corresponding F and then multiplied by 100. As graphically shown in fig. 16, the modified fracturing acceleration ($A \times \frac{100}{F}$), will be seen to be approximately proportional to the inverse square of $2f$.

Again, fig. 17 illustrates the relation between the heights and the fracturing accelerations of columns Nos. 13-13'''. The value of A will be seen to diminish very quickly with the increase of $2f$.

TABLE V.—RELATION BETWEEN THE HEIGHTS OF THE
COLUMNS AND THE FRACTURING ACCELERATIONS.

$2x$ = thickness of brick column. A = max. acc. of the shaking table.
 $2y_0$ = height of column above the section of fracture.
 F = tensile strength of column.

No. of Column	$2x$ mm.	Area of sec. sq. mm.	$2y_0$ mm.	A mm./sec. ²	F lbs. per sq. in.	$A \times \frac{100}{F}$ mm./sec. ²
11	111	$\overline{111}^2$	720	7900	47.4	16700
14"	110	110 × 230	970	3270	33.7	9750
14'''	"	"	680	8950	"	26500
10	111	$\overline{111}^2$	760	5850	45.1	13000
12	110	$\overline{110}^2$	768	2790	33.4	8350
13	"	110 × 232	1550	1570	34.2	4580
13'	"	"	1290	1790	19.3	9280
13"	"	"	1080	"	34.2	5230
13'''	"	"	900	5570	"	16300
13''''	"	"	610	13400	"	39300
15	"	"	1040	2720	44.7	6100
15"	"	"	756	8950	30.2	29600

21. *Hollow columns.*—Equation (5), which gives the seismic stability of a hollow square column of uniform section, may be written as follows :—

$$\alpha = \frac{2gF}{3w \cdot 2f^2} \left(x_0 + \frac{x_1^2}{x_0} \right).$$

The α thus defined is greater for given values of x_0 and $2f$, than that defined by equation (4), which represents the stability of a corresponding solid square column. This leads to the conclusion that for given values of height and external dimensions, the hollow square column has a greater seismic stability than the solid one, the sides or walls in the former case being assumed to be sufficiently thick and rigid to warrant the employment of equation (5).

22. *Column of the uniform strength.*—For a column of uniform section equation (3) may be written :—

$$\alpha = \frac{Igs}{2x_0ws \cdot f^2}, \quad (7)$$

s being the sectional area. Since I , x_0 and s remain constant for different sections, α is inversely proportional to the square of $2f$. Such a column is therefore weakest at the base. (See table III.) This conclusion applies equally well to brick or iron-pipe piers of bridges, as has been exemplified by the damage caused by the great earthquake of Oct. 28th 1891 to the Kiso, Nagara, Ibi and other railway bridges, which were all broken at their feet. Let us next calculate the form, which would give to the column a uniform seismic stability.

A column of the uniform strength must evidently terminate in a point or line top, as shown in fig. 18. Let the origin of coordinates be taken at the top, the axis of x horizontally, and the axis of y vertically downwards.

(a). Let the section be square. Let $2x_0$ be the length of the side

of a given section and y_0 its distance from the top, and let V and f be the volume and the height of the centre of gravity of the portion of the column above that section. We have then the following equation :—

$$f = \frac{\int_0^{y_0} 4x^2 (y_0 - y) dy}{V}.$$

Whence equation (3) may be written :

$$a = \frac{4gF \cdot x_0^3}{3wfV} = \frac{gFx_0^3}{3w \int_0^{y_0} x^2 (y_0 - y) dy}.$$

To make a constant in the above equation, we find, by Calculus of Variation, the following relation between x_0 and y_0 :

$$y_0^2 = \frac{10gF}{aw} x_0 \quad (8)$$

This represents a parabola whose apex is at the origin of coordinates, and whose concavity is turned outwards as shown in the figure which has been drawn from the equation.

$$y_0^2 = 64500x_0 \quad (\text{units in inches.})$$

obtained from the following data :—

$a = 1000$ mm. per sec. per sec. (*i.e.* the intensity of motion in the low portions of Tokyo at the time of the earthquake of June 20th 1894) ;

$F = 40$ lbs. per sq. in. (*i.e.* the average value of the tensile strength of the brick-work damaged in Tokyo by the same earthquake) ;

$w = 0.0608$ lb.

(*b*). Let the section be rectangular, its breadth, or dimension

normal to the earthquake motion, being $2b$. Equation (3) may be written :

$$\alpha = \frac{4gFbx_0^2}{3wfV} = \frac{gFx_0^2}{3w \int_0^{y_0} x(y_0 - y)dy},$$

in which $2x_0$ is the thickness or dimension in direction of the earthquake motion, y_0 , V and f having the same signification as in (a).

The constancy of α requires again the following parabolic relation between x_0 and y_0 :

$$y_0^2 = \frac{4gF}{\alpha w} x_0 \quad (9)$$

(c). Let the section be circular. We have in this case

$$\alpha = \frac{\pi gF x_0^3}{4wfV} = \frac{gF x_0^3}{4w \int_0^{y_0} x^2(y_0 - y)dy},$$

in which $2x_0$ is the diameter of any given section, y_0 , V and f having the same signification as before. The constancy of α leads to the following equation :

$$y_0^2 = 7\frac{1}{2} \cdot \frac{gF}{\alpha w} x_0 \quad (10)$$

Comparing the three equations, (8), (9) and (10), we see that for given values of height (y_0) and basal dimension ($2x_0$), the column of rectangular section has the highest seismic stability.

23. *Applications to brick bridge-piers.*—Let the breadth, or dimension of the section in direction of the earthquake motion, be constant and equal to $2b$. In this case we have to determine the top and base dimensions of the pier according to equation (9) in such a manner that the girders, rails and sleepers may be substituted for its truncated portion without much affecting the condition of uniformity of strength.

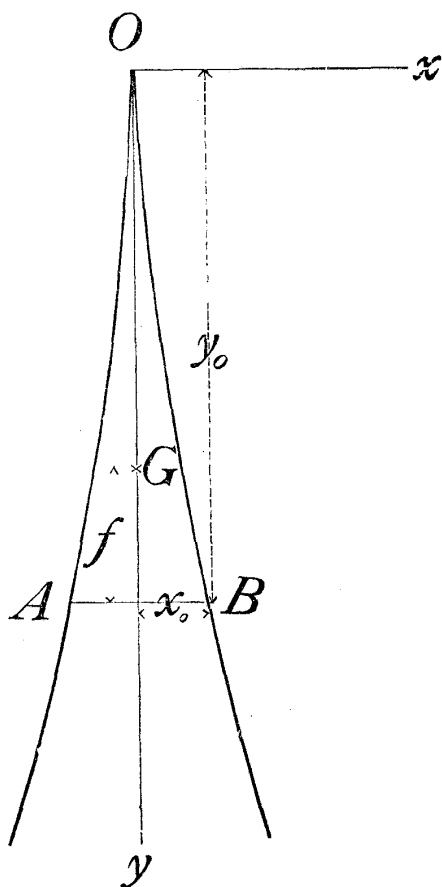

Let AOB represent the vertical section of a rectangular brick pier of uniform strength. If W be the weight of the column above any given section AB, and if f be the height of its centre of gravity, we obtain from equation (9),

$$W = 4bw \int_0^{y_0} x dy = \frac{abw^2 y_0^3}{3gF}, \quad (11)$$

$$\text{and } f = \frac{\int_0^{y_0} 4bx(y_0 - y) dy}{\text{vol. OAB}} = \frac{y_0}{4}. \quad (12)$$

Suppose now the portion AOB to be removed, and the girders, rails and sleepers to be put on the top of the pier thus formed. The bending moment of the load with respect to the section AB, when the maximum acceleration of the earthquake motion is a , is

$$\frac{W'}{g} \times h a,$$

W' being the weight of the load and h the height of its centre of gravity above AB. Equating this to the bending moment of the portion AOB of the original column with respect to AB, we obtain, from equations (11) and (12),

$$\frac{W' h a}{g} = \frac{a^2 b w^2 y_0^4}{3 g^2 \cdot 4 F}; \text{ or } y_0^4 = \frac{12 g F W' h}{a b w^2}; \quad (13)$$

$$\text{and } x_0^2 = \frac{y_0^4 a^2 w^2}{16 g^2 F^2} = \frac{3 h W' a}{4 b g F}. \quad (14)$$

Equations (13) and (14) give the width ($2x_0$) and the distance (y_0) from the apex of the parabola of the top (AB) of the pier, its form and basal dimension being then given by equation (9). The pier thus determined is somewhat stronger at its top than at its base, but it is to be considered as having nearly a uniform seismic stability when compared to ordinary vertical piers.

As an illustration let us take a case analogous to the Kiso Railway-bridge, supposing

$$F = 65 \text{ lbs. per sq. in.,}$$

$$w = 0.0608 \text{ lb.,}$$

$$W' = 200 \text{ tons,}$$

$$h = 10 \text{ ft.,}$$

$$\alpha = 3000 \text{ mm. per sec. per sec.,}$$

$$f = 30 \text{ ft.}$$

If, further, the height of the pier be 30 feet, equations (13) and (14) give respectively

$$y_0 = 674 \text{ in.,}$$

and $2x_0 = 5 \text{ ft. } 5 \text{ in.}$

Again, equation (9) becomes (writing x, y for x_0, y_0)

$$y^2 = 13970 x, \quad (x \text{ and } y \text{ expressed in inches})$$

from which the thickness at the base is found to be 12 ft. 9 in. The form of the pier thus calculated is shown in fig. 19, the curvature of the two parabolic faces being so slight, that we may substitute inclined planes for the latter.

24. *The Kiso Railway-Bridge.*—As an application of equation (4), I shall calculate the seismic stability of the brick piers of the Kiso Railway-bridge, which was destroyed by the great Mino-Owari earthquake of Oct. 28th 1891.

(a). *Construction of the bridge.* The bridge consisted of nine 200 ft. span girders of wrought iron each weighing 156,7 tons. As the

weight of the rails and sleepers was 8,9 tons per 200 ft., the load supported by a single pier amounted to 165,6 tons. The height of the girders was 19 ft. 4,8 in., and the height of their centre of gravity about $9\frac{1}{2}$ ft.

The foundation was formed by a pair of circular wells 12 ft. in diameter, joined together at the top by an arch on which the pier or abutment was constructed. (See figs. 20 and 21.) The mortar was composed of 1 part of cement and 2 or 3 parts of sand.

The height, thickness and width of the pier, which was provided at each end with a triangular buttress, were respectively 30 ft. 9 in., 10 ft. and 21 ft.

(b). *The intensity of the earthquake motion.* With reference to the intensity of the earthquake motion at the Kiso bridge, I give next the result of my observations at the towns of Ichinomiya (in the

province of Owari) and Kasamatsu (in the province of Mino), both in the vicinity of the bridge.

At Ichinomiya, about 4 km. from the bridge, the maximum horizontal acceleration was between 2500 and 3500 mm. per sec. per sec., the direction of motion being WNW and ESE.

At Kasamatsu, situated immediately to the north of the bridge, the maximum horizontal acceleration was about 4000

mm. per sec. per sec., the direction of motion being WNW and ESE.

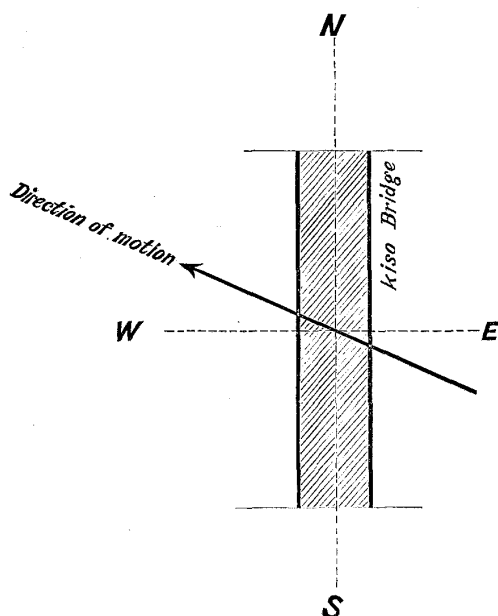

The direction of motion in the vicinity of the Kiso bridge thus seems to have been WNW and ESE, and the greatest displacement of the ground probably took place towards WNW, as the majority of stone lanterns and similar bodies were overturned in that direction. Assuming the maximum acceleration of the earthquake motion at the bridge (whose length was parallel N and S) to be the same as that at Kasamatsu, viz. 4000 mm. per sec. per sec., we obtain the following results.

The intensity of motion in the N and S direction, i.e. normal to the piers, $=4000 \times \sin 22^\circ\frac{1}{2} = 1500$ mm. per sec. per sec.

The intensity of motion in the E and W direction, i.e. normal to the length of the bridge $=4000 \times \cos 22^\circ\frac{1}{2} = 3700$ mm. per sec. per sec.

- (c). *The damage to the bridge.* Each of the wells suffered more or less displacement, while the abutments and the piers were without exception fractured. As will be seen from figs. 22 and 23, each of the piers was broken at, or very near to the arched junction with the well and displaced 3 to 8 in. towards south and west; the abutments were cleanly broken horizontally at the junction with the arch at the back.

Piers (or abutments) like those of the Kiso bridge are apparently strong enough, but their seismic stability may turn out when calculated to be very low, as the fracturing force which is equivalent to the product of the combined mass of the pier, girders, etc., and the maximum acceleration of the earthquake motion, is also very great.

- (d). *Wells.* The employment of a pair of circular wells joined together by an arch is seismically very bad, its defects being two fold. Firstly, the two wells would be caused to assume independent movements, necessitating the formation of cracks at the junction

with the pier. Secondly, the arch reduces very much the sectional area of the pier at its weakest place, the base. Thus in the case of the bridge under discussion, the width of the basal section of the pier was 21 ft. while the diameter of the arch was 7 ft. 4 in., the seismic stability of the pier for earthquake motion normal to its plane, being reduced by one-third of its total value. An elliptical well on the other hand is free from these defects and is seismically a very strong construction.

- (e). *The tensile strength of the brick-work of the Kiso Bridge.* After the great earthquake of Oct. 28th 1891, the authorities of the Imperial Railway Department made a determination of the tensile strength of the brick-work of the bridge. The result is shown in table VI, the average value of the strength being 62.4 lbs. per sq. in.

TABLE VI.—TENSILE STRENGTH OF THE BRICK-WORK OF THE PIERS AND ABUTMENTS OF THE KISO RAILWAY BRIDGE, DAMAGED BY THE GREAT EARTHQUAKE OF OCT. 28TH 1891.*

Place whence brick specimen was taken.	Tensile strength per. sq. in. (lbs.)	Remarks.
No. 6 pier	103.	
No. 5 pier	43.	
"	59.	Broke partly through bricks.
No. 8 pier	57.6.	
No. 7 pier. South part of up stream side of arch.	141.	Broke at joint.
No. 5 pier. North part of up stream side well.	88.	Broke through bricks.
No. 5 pier. North part of up stream side of middle layer.	65.	Broke at joint.
No. 5 pier. North part of down stream side of arch.	168.	Broke partly through bricks and partly along mortar joint.
No. 3 pier. South side surface of middle layer.	0	Simply dropped apart.
No. 2 pier. South side surface of arch.	0	"
No. 1 pier. South side surface of arch.	—	Held on to 63 lbs. per sq. in., did not break.
South abutment. North side surface beneath bedstone.	36.	Clean separation at joint.
No. 2 pier. North side surface of middle layer.	26.	Broke through bricks.
No. 2 pier. North side surface of arch.	81.	Clean separation at joint.
No. 2 pier. South side surface of middle layer.	41.	"
South abutment. South interior part beneath bedstone.	49.	Separation at joint.
No. 1 pier. North side surface of middle layer.	41.	Clean separation at joint.
No. 1 pier. North side surface of arch.	93.	Broke partly through brick and partly through mortar.
No. 3 pier. North side surface beneath bedstone.	63.	Clean separation at joint.
No. 3 pier. South side surface beneath bedstone.	60.	"
No. 3 pier. North side surface of arch.	54.	Broke entirely through bricks.
No. 2 pier. North side surface at base of pier.	92.	Broke at joint.
No. 2 pier. South side surface at base of pier.	0	Simply dropped apart.
South abutment. North side surface of middle layer.	51.	Clean separation at joint.
No. 3 pier. North side surface of middle layer.	98.	Broke entirely through bricks.
No. 1 pier. South side surface at base of pier.	51.	Clean separation at joint.
No. 3 pier. South side surface of arch.	62.	"

Average value of the tensile strength per. sq. in. = 62.4 lbs.

* Determined by the Imperial Railway Department.

(f). *Calculation of the seismic stability of the pier.*—The pier was theoretically weakest, and actually broke at the junction with the wells. The seismic stability or acceleration of the earthquake motion (a) necessary for fracturing normally the pier at this section can be calculated by the formula :

$$a = \frac{g F I}{W f x_0}$$

The signification of the several symbols in this equation is as follows.

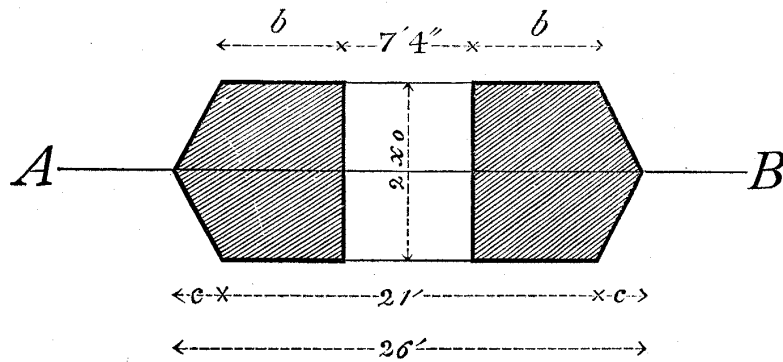

$$\begin{aligned} 2x_0 &= 10' & c &= 2' 6'' \\ b &= 6' 10'' \end{aligned}$$

g is the acceleration due to gravity, = 9800 mm.

x_0 ,, half thickness of the pier, = 60 in.

F ,, tensile strength of the brick-work per sq. in., = 62.4 lbs.

(See table VI).

I ,, moment of inertia of the section of fracture with respect to its longer axis AB (see the figure), or

$$I = \frac{4bx_0^3}{3} + \frac{2x_0^3c}{6} = \frac{2x_0^3}{3} \left(2b + \frac{c}{2} \right)$$

$$= \frac{2 \times 60^3}{3} (14' 8'' + 15'')$$

$$= 25,770,000. \quad (\text{expressed in inches}).$$

W is the weight of the whole structure above the top of the well, or

$$\begin{aligned} W &= (\text{weight of the girders, rails, etc.}) \\ &+ (\text{weight of the brick pier}) \\ &= 165,6 \text{ tons} + (0,0608 \text{ lb.} \times \text{vol. of the pier}) \\ &= 371.000 \text{ lbs.} + (0,0608 \text{ lb.} \times 11.019.700 \text{ c. in.}) \\ &= 1.051.800 \text{ lbs.} \end{aligned}$$

f is the height of the centre of gravity of the same, = 294 in.

Substituting these values in the above equation, we find

$$a = \frac{9800 \times 62,4 \times 25.770.000}{1.051.800 \times 294 \times 60} = 850 \text{ mm. per sec. per sec.}$$

This value of a , which represents the seismic stability of the pier normal to its plane, will be seen to be far smaller than the actual N and S component intensity of the earthquake-motion at the Kiso-gawa, namely, 1500 mm. per sec. per sec. This shows how small the seismic stability of ordinary bridge piers is.

If the foundation of the pier had consisted of a single elliptical well, instead of a pair of circular ones joined by an arch, the seismic stability of the same pier would have been 1270 mm. per sec. per sec., the loss of the strength due to the existence of the arch thus amounting to $1270 - 850 = 420$ mm. per sec. per sec.

III. CHIMNEYS.

25.—*Chimneys* mean here only brick factory-chimneys.

Chimneys are broken by earthquake motion usually a little above the middle height, it being extremely rare that they receive damage near the base. This fact has already been observed at the time of the great Mino-Owari earthquake of Oct. 28th 1891, and

has been explained by Mr. K. Nakamura, Director of the Central Meteorological Observatory, on the assumption that these columns are weakest at the height corresponding to the centre of percussion with respect to the base.

The top portion of a chimney, when thrown down, has never been projected to a great distance from the base. Again, the broken portion very often does not fall down but remains at its original height and presents the phenomenon of rotation. It is probable also that an earthquake motion of great amplitude is required to overturn columns or structures of large dimensions.

Of the 49 factory chimneys * broken at the time of the Tokyo earthquake of June 20th 1894, only eleven had the top portion thrown down, as shown in the following table.

Chimney.	Total height. <i>Shaku</i> .†	Height of the section of fracture. <i>Shaku</i> .	Distance between the centre of the chimney base and the point of projection. <i>Shaku</i> .	Distance between the chimney foot and the point of projection. <i>Shaku</i> .	Direction of projection.
Tokyo Hōhei-Kōshō.	70.4	56.9	16.1	11.1	—
Paper-tile Factory, Fukagawa.	42.	32.2	23.	20.	S60°W
Onagigawa Brick Factory, Fukagawa.	132.	68.	25.	17.	S75°W
Okada Seimai-sho, Fukagawa.	60.	40.	20.	17.	E
Tokyo Shiuji-kan.	150.	130.	20.	13.	N10°W
Do.	120.	111.8	13.	7.	SW
Kakizawa Factory, Honjō.	70.	47.3	15.	9.	NE
Okura Factory, Fukagawa.	75.	49.	30.	24.	N73°E
Tanaka Factory, Fukagawa.	78.	60.	17.	11.	S75°W
Sakurada Beer Company.	50.	28.5	15.	11.	S55°E
Tokyo Seifun Company, Fukagawa.	50.	30.	22.	18.	N40°E

* See the report by Messrs. Mano, Tanabe and Yasunaga, 5th Vol. of the Report of the Earthquake Investigation Committee.

† 1 *shaku* = 300 mm.

According to the above table, the maximum distances of the point of projection of the broken top from the centre and the exterior side of the chimney base were respectively 30 and 24 ft., there being no definite relation between these distances and the heights of the chimneys.

The forty-nine chimneys already referred to were broken at the $\frac{3}{10}$ th to $\frac{4}{10}$ th part of their heights, which varied between 39 and 150 *shaku*. The mean height of the plane of fracture deduced from all these forty-nine cases, which is at the $\frac{6}{10}$ th part of the chimney height, may be regarded as defining statistically the probable point of fracture of chimneys.

Again, according to the report by Messrs. Mano, Tanabe and Yasunaga, the tensile strength of the joint of the brick-work, tested in the cases of eleven chimneys, varied between 19.3 and 58.2 lbs. per sq. in., giving an average of 36.1 lb. per sq. in. It is however, to be noted that this value represents the mean strength of the stronger portions of the brick-work, those test pieces whose strength was nearly zero and too weak to be tested, having been excluded from the experiment.

26. *Period of vibration of brick columns.*—The following table gives the result of experiments made on the free vibration of the six brick columns Nos. 13, 13''', 13''''', 15, 21* and 24 (tables I and III); the double amplitude and the period having been measured from the diagrams traced by a rigid pointer attached to the top of each column, which was set in motion by striking it with the hand. See figs. 24-27.

No. of column.	Thickness. mm.	Height. mm.	Maximum range of motion. mm.	Average period. sec.	Remarks.
13	110	1700	9.6	0.16	The square of the ratio of the heights of the columns, Nos. 13 and 13''' = 2.66; the ratio of their periods = 2.4.
13'''	"	990	3.	.072	
13'''''	"	810	2.	.053	
15	"	1800	11.	.20	The square of the ratio of the heights of the columns, Nos. 13''' and 15 = 1.49; the ratio of their periods = 1.4.
21*	233-131	1810	4.5	.11	
24	220	1587	1.9	.10	The column No. 21* is hollow, all the others being solid.

The *height* in the third column of the table, which gives the mean of the whole height of a column and its height above the iron fixing frame (fig. 6), is intended to represent the effective length coming into play in the free vibration.

From the above table the period of vibration of a column will be seen, as ought to be, nearly proportional inversely to the thickness and directly to the square of the height. Thus the thickness of the two columns Nos. 15 and 21*, whose heights are nearly equal, are in the ratio of 1 : 2, while their periods are in the ratio of 2 : 1. Again, the periods of the three columns Nos. 13, 13''' and 13,''' whose sections are equal to one another, are roughly in the ratios of the squares of their heights.

The period of free lateral vibration of the six columns experimented upon, which varied between 0.053 and 0.20 second, is rather slower than might have been supposed. These numbers may be used for estimating roughly the period of vibration of a given column. Let us suppose, for instance, the height and thickness of a square brick column to be respectively 30m. and 3m. the quality of the brickwork being similar to that of column No. 24. The period of the given column will then be about 2.6 seconds.

27. *Period of vibration of chimneys.* In the 21st volume of the Report of the Earthquake Investigation Committee, there is an interesting report by Messrs. Mano and Tanakadate on the vibration of a chimney which belonged to the former astronomical observatory of the University. The section of the chimney, whose height was 19,6 *shaku*, was nearly uniform and 2,7 *shaku* square.

According to the experiments by Messrs. Mano and Tanakadate, the period of vibration of the chimney increased somewhat with the amplitude. Thus for instance, in one experiment the average period of vibration was 0.55 second, while the period of the maximum

motion, whose range (at the top of the chimney) was 90 mm., was 0,85 second. In another case, the average period was 0.62 second, while the period of the maximum motion, whose top range was 162 mm., was, 0.99 second. From these results it may be concluded that the period of vibration of the chimney in question at the time of a great earthquake would be about one second.

Let us now imagine for the sake of illustration, a solid brick square column, whose height and thickness are five times those of the chimney above considered, viz. 98 and 17,5 *shaku* respectively. If the material of the supposed column be exactly similar to that of the chimney, the period of vibration of the former may be inferred from that of the latter to be about 5 seconds. This result, though only roughly approximate, shows that the period of large brick columns and consequently also of chimneys, would be very slow. As a matter of fact slow oscillations are usually perceived at the top of large chimneys.

28. *Height of the weakest section of chimneys.*—From § 27, it follows that a large brick chimney behaves at the time of a destructive earthquake as if the “centre of percussion” really existed, the period and the height of the chimney being many times greater than the period and range of the earthquake motion. In this case, the centre of percussion, which is at the same time a *steady point*, marks theoretically the weakest place of the chimney. (See § 25.) I shall next give a few practical illustrations.

(a). *The chimney of the Goryō-kyoku Factory at Ōji*—This chimney, whose height was 100 *shaku* and whose section was circular, was broken by the earthquake of June 20th 1894 at the height of 61 *shaku*. (See fig. 28.)

Theoretically the centre of percussion of this chimney was at the height of 54,4 *shaku*; while the calculated position of the section of

fracture would be according to § 25 at a height of $100 \times \frac{67}{100} = 67$ *shaku*. These two values must, in calculations of this kind, be regarded as sufficiently close to one another, and give the mean height of 60,7 *shaku* for the most probable section of fracture, which conclusion has almost exactly been fulfilled in the actual case. I am, however, inclined to regard this result as indicating the accidental weakness at the particular height of 61,7 *shaku*, since the chimney might have been broken more easily 2,9 *shaku* higher at the height of 64,6 *shaku*, where there had existed a discontinuity in the thickness of the brick-work.

(b). *The Great Chimney of the Imperial Steel Works.*—The height of this chimney, now in the course of construction, is 80 m., its external slope being $\frac{3.75}{100} = 0,0375$. The section is circular, the outer diameters at the base and the top being respectively 7,80 and 4,36 m. (fig. 29.)

The centre of percussion of the chimney is found by calculation to be at the distance of 42,6 m. from base, or a little above the middle height. On the other hand the calculated coefficient of $\frac{67}{100}$ (§ 25), gives the weakest point at the height of $80 \times \frac{67}{100} = 53,2$ m. Taking the mean of these two results, we get the value of 48 m. for the probable height of fracture. As, however, there is a discontinuity in the thickness of the wall 2 m. lower, (AB in the accompanying figure), the natural conclusion is to suppose the weakest section to be at the height of 46 m.

29. *Seismic stability of chimneys.* According to the results obtained above, chimneys seem to be seismically weakest at the height y' given by the following equation :

$$y' = \frac{1}{2} \left\{ h + \left(y_0 \times \frac{67}{100} \right) \right\}, \quad (15)$$

in which y_0 is the total height, and h the height of the centre of percussion. It is to be remarked that this equation implies uniformity of construction throughout the chimney.

Having determined by equation (15) the probable height of fracture of a given chimney, we can calculate its seismic stability by equation (3) :

$$a = \frac{gFI}{x_0fwV}, \quad (3)$$

in which the several symbols have the same signification as before, the only difference being that the section of fracture is no longer at the base. When the section is circular, we obtain

$$a = \frac{\pi gF(d_2^4 - d_1^4)}{32d_2fwV}, \quad (16)$$

in which d_2 and d_1 are respectively the outer and the inner diameters of the section of fracture. As examples I shall calculate the seismic stability of the two chimneys already considered.

(a) *The chimney of the Goryō-kyoku Factory at Ōji.* In this case, we have :—

The height of the section of fracture = 61,7 *shaku*,

$d_2 = 9,2$ *shaku*,

$d_1 = 5,5$,,

$V =$ volume of the portion fractured = 1110 cubic *shaku*,

$f =$ height of the centre of gravity of the same portion above the plane of fracture = 17,3 *shaku*,

$F = 54.4$ lbs. (adopting the result obtained by Messrs. Mano, Tanabe and Yasunaga, from the testing experiments on the brick-work of this chimney).

Substituting these values in equation (16), we find

$$a = 8,41 \text{ shaku} = 2550 \text{ mm. per sec. per sec.},$$

which gives the seismic stability of the chimney. As already remarked however, there is reason for supposing the strength of the brick-work at the section of fracture to have been imperfect, the tensile strength of $F = 54.4$ lbs. per sq. in. being consequently too high. It is

probable that the chimney was broken actually by an intensity of earthquake motion much lower than the above value of α .

(b). *The Great Chimney of the Imperial Steel Works.* We have:—

The height of the probable section of fracture = 46 m.

$$d_2 = 5,585 \text{ m.}$$

$$d_1 = 4,865 \text{ m.}$$

$$f = 14,5 \text{ m.}$$

$$wV = \text{weight of the portion to be fractured} = 269,31 \text{ French tons.}$$

Assuming F to be 34,6 French tons per sq. m., (which corresponds to the tensile strength of 50 lbs. per sq. in.), we obtain

$$\alpha = 634 \text{ mm. per sec. per sec.}$$

It is to be remarked that the value of F used in the calculation is much higher than the average in ordinary cases. (See § 25.) The seismic stability α will, however, be seen to be much smaller than that of the Oji chimney, due doubtless to the difference in height. It is probable that very tall chimneys can never resist great earthquakes. If possible therefore, the reduction of the height of chimneys is seismically very important.

I may here add that the design of this great chimney of the Imperial Steel Works has subsequently been changed, the height having been reduced to 70 m. without altering the thickness of the brick-work.

IV.—OVERTURNING OF COLUMNS.

30. Overturning experiments were made in connection with the determination of the intensity of motion of destructive earthquakes. Consequently the dimensions of the columns employed in the

experiments have been of magnitude comparable to those of the stone lanterns, tomb-stones, etc., observed in actual cases.

The details of the columns, whose number amounted to 42, are given in table VII. Of these, two were iron pipes, 8 solid or hollow brick columns, 18 hollow columns or boxes of wood, and the remaining 14 solid columns of wood.

The bases of the wooden columns, as illustrated in Fig. 30, were made slightly concave, so as to make them sit well. For brick columns, a similar precaution has been taken.

The height of the columns varied between 1150 and 242 mm. and the dimension of the section between $\overline{300^2}$ and $\overline{90^2}$ sq. mm.

TABLE VII.—LIST OF THE COLUMNS OVERTURNED.

No.	Dimensions* (in mm.)	No.	Dimensions* (in mm.)
	(I) Iron pipes, (7 mm. thick).		(V) Solid Square Columns of Wood.
k_1	(diameter) 152; (height) 940	G ₁	120×120×970
k_2	(") 150; (") 480	G ₂	" " 843
	(II) Solid Square Columns of Brick.	G ₃	" " 727
l_1	230×230×1150	G ₄	" " 595
l_2	230×230×700	G ₅	" " 480
l_3	230×230×660	G ₆	" " 362
	(III) Hollow Square Columns of Brick.	G ₇	" " 242
m_1	230×230×1100, (54 mm. thick).	H ₁	90×90×726
o_1	185×185×950, (45 " ").	H ₂	" " 665
n	233×233×900, (50 " ").	H ₃	" " 637
m_2	230×230×790, (54 " ").	H ₄	" " 544
o_2	183×183×600, (45 " ").	H ₅	" " 450
	(IV) Hollow Square Columns of Wood, (1 cm. thick.)	H ₆	" " 361
A ₁	300×300×900	H ₇	" " 270
A ₂	" " ×605		
B	274×274×817		
C ₁	242×242×970		
C ₂	" " 727		
C ₃	" " 484		
D ₁	210×210×850		
D ₂	" " 633		
D ₃	" " 420		
E ₁	180×180×907		
E ₂	" " 727		
E ₃	" " 544		
E ₄	" " 362		
F ₁	151×151×910		
F ₂	" " 754		
F ₃	" " 602		
F ₄	" " 450		
F ₅	" " 304		

* The dimensions are the outside dimensions.

31. *Method of the experiments.*—The method of the experiments consisted in putting the columns on the shaking table and overturning them by giving proper movements to the latter. The shaking intensity deduced from the diagram of motion of the table was then compared with the theoretical values of the acceleration necessary for overturning the columns. Specimen diagrams are shown in figs. 31 and 32.

In the experiments, the range of motion of the shaking table varied between 29.5 and 120 mm., and the period between 0.4 and 1.47 seconds. Further, the maximum acceleration of motion varied between 750 and 10,700 mm. per sec. per sec. The column C₃, however, could not be overturned even with the utmost intensity of motion at our disposal, which fact shows the difficulty of overturning certain stable objects by earthquakes. The result of the experiments is shown in table VIII.

TABLE VIII.—SUMMARY OF RESULTS OF THE
OVERTURNING EXPERIMENTS.

$2x$ = thickness of column ;
 $2y$ = its height ;
 $\alpha = \frac{x}{y} g$ = acceleration, which may over-
 turn the column.

$2a$ = range of motion of the shaking table ;
 T = its period ; A = its maximum accelera-
 tion.

No. of Column.	$2x$ mm.	$2y$ mm.	$\alpha = \frac{x}{y} g$ mm./sec. ²	$2a$ mm.	T sec.	A mm./sec. ²	Ratio $\frac{a}{A}$
l_1	230	1150	1960	100	0.89	2480	0.8
m_1	230	1100	2050	110	1.11	1760	1.2
o_1	185	950	1910	108	1.27	1310	1.5
n	233	900	2540	111 110	1.00 .90 mean	2190 2670 2430	1.0
m_2	230	790	2860	110 111	.96 .87 mean	2350 2890 2620	1.1
l_2	230	700	3220	104	.69	4280	0.8
l_3	230	660	3400	114	.77	3780	0.9
o_2	183	600	3040	111	.83	3180	1.0
k_1	152	940	1580	32 113 110	.77 1.14 1.47 mean	1060 1720 1000 1260	1.3
k_2	150	480	3160	114 113 32 114	.90 .92 .61 .95 mean	2770 2640 1700 2480 2400	1.3

No. of Column.	2x mm.	2y mm.	$\alpha = \frac{x}{y} g$ mm./sec. ²	2a mm.	T. sec.	A. mm./sec. ²	Ratio $\frac{\alpha}{A}$
A ₁	300	900	3260	114	0.79	3600	0.9
B	274	818	3290	114	.79	3600	0.7
				116	.66	5240	
				mean		4420	
C ₁	242	970	2450	113	.88	2870	1.0
				112	1.00	2210	
				mean		2540	
C ₂	242	727	3260	114	.77	3780	0.8
				116	.62	5950	
				114	.81	3420	
				111	.85	3020	
				mean		4040	
C ₃	242	484	4900	119	.51	9000	—
				120	.47	10700 (not overturned)	
						10700 (not overturned)	
D ₁	210	850	2420	113	.88	2870	1.0
				"	.91	2700	
				110	.96	2350	
				33½	.46	3120	
				mean		2510	
D ₂	210	634	3250	114	.78	3700	1.0
				"	.81	3420	
				111	.86	2960	
				"	.82	3250	
				mean		3330	
E ₁	180	908	1940	112	1.01	2160	
				"	1.09	1860	
				32	.56	2010	
				34½	.34	5900(?)	
				32½	.48	2780	

No. of Column.	$2x$ mm.	$2y$ mm.	$\alpha = \frac{x}{y} g$ mm./sec. ²	$2a$ mm.	T sec.	A mm./sec. ²	Ratio $\frac{\alpha}{A}$
E_1	180	908	1940	33 35	0.48	2830	0.7
					.41	4100	
					mean	2620	
E_2	180	727	2430	100	.83	2860	1.0
				"	.86	2660	
				113	.98	2320	
				112	1.04	2040	
				110	.99	2220	
				111	.96	2370	
				110	.94	2450	
				mean	2420		
E_3	180	544	3240	114	.77	3780	0.9
				"	.80	3510	
				"	.86	3040	
				mean		3440	
E_4	180	362	4870	116	.62	5950	0.8
				"	.63	5750	
				mean		5850	
F_1	152	910	1640	113	1.14	1720	1.2
				110	1.33	1230	
				$31\frac{1}{2}$.71	1230	
				$30\frac{1}{2}$.67	1340	
				$32\frac{1}{2}$.53	2280	
				30	.97	630	
				$29\frac{1}{2}$.75	1030	
				$30\frac{1}{2}$.75	1070	
				30	.69	1240	
				mean		1310	
F_2	152	754	1960	112	1.09	1860	
				30	.84	840	
				$31\frac{1}{2}$.59	1780	
				32	.55	2080	
				$32\frac{1}{2}$.63	1610	
				31	.48	2650	

No. of Column.	2x mm.	2y mm.	$\alpha = \frac{x}{y} g$ mm./sec. ²	2a mm.	T sec.	A mm./sec. ²	Ratio $\frac{\alpha}{A}$
F ₂	152	754	1960	29½ 30½	0.75	1030	1.2
					.69	1260	
					mean	1640	
F ₃	152	602	2470	112	1.04	2040	1.2
				31	.60	1700	
				29½	.65	1370	
				31½	.57	1910	
				32	.45	3100	
				mean		2020	
F ₄	152	450	3310	114	.86	3040	1.2
				113	.87	2950	
				32½	.50	2560	
				33	.46	3070	
				32½	.57	1980	
				mean		2720	
F ₅	152	304	4900	117	.66	5290	0.9
				116	.66	5240	
				mean		5270	
G ₁	120	970	1210	110	1.30	1280	1.2
				31½	.82	920	
				"	.81	950	
				"	.84	880	
				mean		1010	
G ₂	120	844	1390	110	1.30	1280	1.5
				31½	.91	750	
				"	.91	750	
				"	.84	880	
				mean		920	
G ₃	120	728	1620	111	1.28	1330	1.5
				31½	.81	950	
				"	.84	880	
				"	.75	1100	
				mean		1070	

No. of Column.	$2x$ mm.	$2y$ mm.	$\alpha = \frac{x}{y} g$ mm./sec. ²	$2a$ mm.	T sec.	A mm./sec. ²	Ratio $\frac{\alpha}{A}$
G ₄	120	596	1970	112	1.13	1720	
				108	1.27	1310	
				31½	.74	1130	
				"	.80	970	
				"	.68	1340	
				mean	1290	1.5	
G ₅	120	480	2450	112	.99	2250	
				110	1.06	1940	
				110	1.01	2170	
				32	.60	1750	
				34½	.45	3350	
				32	.65	1490	
				55	.81	1500	
				56	.64	2700	
				mean	2140	1.1	
G ₆	120	362	3260	101	.83	2900	
				101	.77	3350	
				"	.81	3030	
				114	.89	2840	
				113	.87	2940	
				114	.84	3180	
				32½	.51	2460	
				"	.50	2560	
				32	.64	1540	
				56½	.63	2800	
				57½	.54	3880	
				mean	2860	1.1	
G ₇	120	242	4860	116	.65	5400	
				"	.68	4950	
				"	.66	5240	
H ₁	90	726	1220	111	1.18	1570	
				"	1.30	1290	
				31½	.90	770	
				"	.91	750	

No of Column.	2x mm.	2y mm.	$\alpha = \frac{x}{y} g$ mm./sec. ²	2a mm.	T sec.	A mm./sec. ²	Ratio $\frac{\alpha}{A}$	
H ₁	90	726	1220	31½	.88	800	0.9	
					.77	1060		
					mean	1040		
H ₂	90	666	1330	111	1.22	1470	0.9	
					1.26	1380		
					31½	.88		800
					„	.89		790
					„	.91		750
					„	.88		800
					„	.85		830
mean	974							
H ₃	90	638	1390	112	1.18	1900	0.9	
					111	1.21		1490
					31½	.81		950
					„	.84		880
					„	.82		930
					mean	1180		
H ₄	90	544	1620	112	1.10	1840	1.3	
					1.19	1570		
					31½	.88		880
					„	.81		950
					„	.72		1200
					„	.74		1130
					30½	.65		1420
mean	1290							
H ₅	90	454	1940	112	1.14	1710	1.2	
					1.12	1770		
					31½	.71		1230
					„	.74		1130
					„	.75		1100
					32½	.50		2560
mean	1600							
H ₆	90	362	2440	113	.98	2320		
					1.06	1990		

No. of Column.	$2x$ mm.	$2y$ mm.	$a = \frac{x}{y} g$ mm./sec. ²	$2a$ mm.	T sec.	A mm./sec. ²	Ratio $\frac{a}{A}$
H ₆	90	362	2440	32	0.65	1490	1.3
				”	.73	1180	
				”	.63	1590	
				32	.63	1590	
				31½	.41	3700	
				”	.58	1850	
				”	.61	1670	
				mean		1930	
H ₇	90	270	3260	115	.85	3140	1.1
				116	.80	3590	
				110	.95	2400	
				35	.45	3390	
				33	.53	2320	
				32½	.60	1780	
				31½	.44	3200	
				32	.40	3950	
				32½	.54	2200	
				mean		2890	

General mean 1.07

The overturning of a column by earthquake motion is a complex phenomenon, incapable of exact solution by a simple formula. Let us however, simplify the question by supposing the period of the earth-motion not very short in comparison with the proper period of rocking of the column. In this case, the body will not be overthrown at once, but will continue to move with the ground so long as the intensity of motion of the latter is not

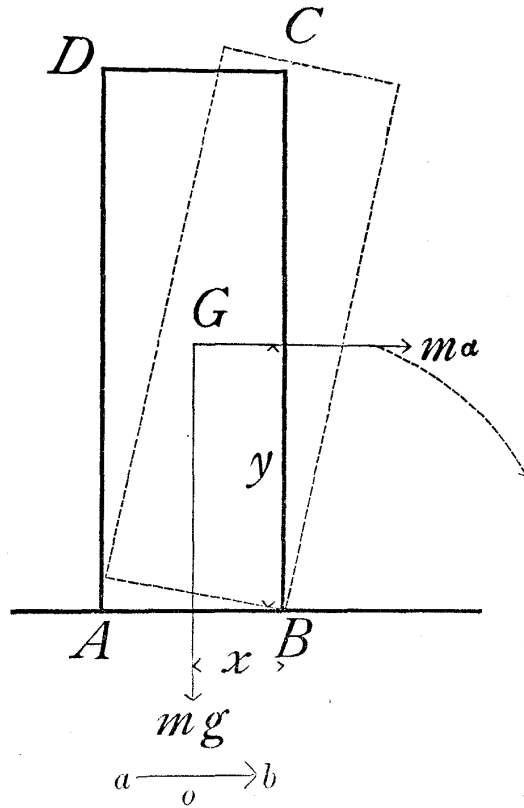

sufficiently great. Let ABCD be a column resting at AB on the ground. Let G be the centre of gravity of the body, y its height, and x the horizontal distance between it and a corner edge B. If at a given moment the ground be moving from the equilibrium position o towards the extremity b , the acceleration (a) will be directed towards o . Impressing now the acceleration a in the opposite direction, uniformly to the column and the ground, we reduce the latter to a state of rest. The motion of the body relative to the ground however, is not thereby altered, the result being that the body is impressed with the acceleration a in direction $o b$. The least value of the earth acceleration necessary for overturning the column whose mass is m is therefore given by the equation :—

$$m a y = m g x$$

or

$$a = \frac{g x}{y} \tag{17}$$

the column being thrown towards the same direction as the motion of the ground. (See the present author's Notes on the Mino-Owari and the Tokyo earthquakes.)

Equation (17) gives, as is well known, the horizontal acceleration necessary for overturning a column at rest. Its introduction to seismology is due to Prof. C. D. West.

According to equation (17), the overturning acceleration α is independent of the material of the columns and depends simply on the ratio $\frac{x}{y}$.

In table VIII, the columns are arranged in groups. The quantity α given in the 4th row has been calculated by equation (17); while the quantity A given in the 7th row is the intensity of motion of the shaking table which actually overturned the body.

The values of α and A will be seen in general to be practically equal to each other, the mean of the ratios $\alpha : A$ being 1.07: 1. It must be remembered however, that this conclusion is limited by the condition that the period of the earthquake motion is not very small in comparison to the period of rocking of the columns.

32. *Remarks on equation (17).*—That the overturning acceleration α is independent of the nature of the material of the columns is shown in table IX. Thus the columns, n, m_2, l_2, l_3, o, k_1 and k_2 were of brick or iron; while the others D_1, D_2, E_3, F_1 and F_2 were wooden boxes. α was, however, nearly the same for the columns of both kinds, when their exterior dimensions were approximately equal.

TABLE IX.—SHOWING THE NON-EXISTENCE OF RELATION BETWEEN THE MATERIAL OF A COLUMN AND ITS OVERTURNING ACCELERATION.

($2x$, $2y$, a and A have the same signification as in Table VIII.)

Column.	Material.	$2x$ mm.	$2y$ mm.	$a = \frac{x}{y}g$ mm./sec. ²	A mm./sec. ²
n } m_2 }	brick	233 } mean 230 } 232	900 } mean 790 } 845	2540 } mean 2860 } 2700	2430 } mean 2620 } 2530
D_1	wood (hollow)	210	850	2420	2510
l_2 } l_3 } o }	brick	230 } 230 } 214 183 }	700 } 660 } 653 600 }	3220 } 3400 } 3220 3040 }	4280 } 3780 } 3570 3180 }
D_2 } E_3 }	wood (hollow)	210 } 180 } 195	635 } 544 } 590	3250 } 3240 } 3250	3330 } 3440 } 3390
k_1	iron pipe	152	940	1580	1260
F_1	wood (hollow)	152	910	1640	1390
k_2	iron pipe	150	480	3060	2400
F_2	wood (hollow)	152	450	3310	2720

33. *An absolute scale of destructive earthquakes.*—In the investigation of the great Mino-Owari earthquake of Oct. 28th 1891, I estimated the intensity of the earthquake motion from the observation of numerous stone lanterns, tomb-stones, etc., with whose dimensions those of the columns in the present experiments were comparable.* As, further, the period of the principal motion in this destructive earthquake was not very short but probably one or two seconds, the values of the maximum acceleration at various places calculated by means of equation (17) must be very near to the truth.

* F. Omori; Note on the great Mino-Owari earthquake of Oct. 28th 1891.

The following *absolute scale of destructive earthquakes*, or the relation between the maximum acceleration of the earthquake motion and the damage produced, has been deduced chiefly from analysis of the Mino-Owari earthquake, the intensity being arbitrarily divided into seven classes *I-VII*. It is to be noted that the scale applies principally to Japan.

- I. Maximum acceleration=300 mm. per sec. per sec.*—The motion is sufficiently strong that people generally run out of doors. Brick walls of bad construction are slightly cracked; plasters of some old *dozo* (godowns) shaken down; furniture overthrown; wooden houses so much shaken that cracking noises are produced; trees visibly shaken; waters in ponds rendered slightly turbid in consequence of the disturbance of the mud; pendulum clocks stopped; a few factory chimneys of very bad construction damaged.
- II. Maximum acceleration=900 mm. per sec. per sec.*—Walls in Japanese houses are cracked; old wooden houses thrown slightly out of the vertical; tomb-stones and stone lanterns of bad construction overturned, etc. In a few cases, changes are produced in hot springs and mineral waters. Ordinary factory chimneys are not damaged.
- III. Maximum acceleration=1200 mm. per sec. per sec.*—About one factory chimney in every four is damaged; brick houses of bad construction partially or totally destroyed; a few old wooden dwelling houses and ware houses totally destroyed; wooden bridges slightly damaged; some tomb-stones and stone lanterns overturned; *shoji* (Japanese paper-covered sliding doors) broken; roof-tiles of wooden houses disturbed; some rock fragments thrown down from mountain sides.

- IV. *Maximum acceleration=2000 mm. per sec. per sec.*—All factory chimneys are broken ; most of the ordinary brick buildings partially or totally destroyed ; some wooden houses totally destroyed ; wooden sliding doors and *shoji* mostly thrown out of the grooves ; cracks 2 or 3 inches in width produced in low and soft grounds ; embankments slightly damaged here and there ; wooden bridges partially destroyed ; ordinary stone lanterns overturned.
- V. *Maximum acceleration=2500 mm. per sec. per sec.* All ordinary brick houses are very severely damaged ; about 3 % of the wooden houses totally destroyed ; a few *tera*, or Buddhist temples, thrown down ; embankments severely damaged ; railway lines slightly curved or contorted ; ordinary tomb-stones overturned ; *ishigaki*, or masonry walls, damaged here and there ; cracks 1 or 2 feet in width produced along river banks ; waters in rivers and ditches thrown over the banks ; wells mostly affected with changes in their waters ; landslips produced.
- VI. *Maximum acceleration=4000 mm. per sec. per sec.* Most of the *tera*, or Buddhist temples, are thrown down ; 50 to 80 % of the wooden houses totally destroyed ; embankments shattered almost to pieces ; roads made through paddy fields so much cracked and depressed as to stop the passage of wagons and horses ; railway lines very much contorted ; large iron bridges destroyed ; wooden bridges partially or totally damaged ; tomb-stones of stable construction overturned ; cracks a few feet in width formed in the ground, accompanied sometimes by the ejection of water and sand ; earthenware buried in the ground mostly broken ; low grounds, such as paddy fields, very greatly convulsed, both horizontally and vertically, sometimes causing trees and vegetables to die ; numerous landslips produced.

VII. *Maximum acceleration much above 4000 mm. per sec. per sec.* All buildings, except a very few wooden houses, are totally destroyed; some houses, gates, etc., projected 1 to 3 feet; remarkable landslips produced, accompanied by faults and shears of the ground.

In the above scale of the seismic intensity, the earthquake motion has been assumed to be entirely horizontal. This supposition would not, except in places very near to the epicentre, cause sensible errors in the result. (See the note on the Mino-Owari earthquake.)

The comparison of the present absolute scale with the Rossi-Forel system and that employed by our Central Meteorological Observatory will be seen from the following schedule.

Absolute scale of destructive earthquakes. (Acc. in mm. per sec. per sec.)	The intensity scale employed by the Central Meteorological Observatory.	Rossi-Forel Scale.
	Slight.	{ I II
	Weak.	{ III IV V
I 300 mm./sec. ²	{ Strong.	{ VI VII
II 900	} Violent.	{ —
III 1200		VIII
IV 2000		IX
V 2500		X
VI 4000		—
VII >4000		—

It may here be noted that the number of (wooden) houses destroyed by an earthquake is not necessarily proportional to the

intensity of the latter. The following list is the result obtained by taking means from numerous observations.

Percentage of (wooden) houses destroyed in a town or village.			Maximum (horizontal) acceleration of the earthquake motion.
(1)	2 or 3	%	2600 mm. per sec. per sec.
(2)	15	„	3400 „
(3)	50	„	3900 „
(4)	80	„	4500 „
(5)	100	„	Infinite

The meaning of (5) is that a few wooden houses could not be totally destroyed by an earthquake, however violent.

34. *Large buildings.*—Equation (17) can not be applied to pagodas, *bell-temples* and other buildings, whose dimensions are very much greater than the range of motion of the ground. As their rocking periods are long, the earthquake motion is to be regarded, with respect to these bodies, as acting in *shocks*. They will never be overthrown, unless the range of motion of the ground amount to several feet.*

35. In the present paper, I have confined myself to the consideration of some of the simplest brick structures. Hollow columns and other structures shall form the subject of the second series of fracturing experiments.

Tokyo. May, 1899.

* See F. Omori: *On the overturning of Columns.* Seis. Jour. Japan. Vol. II.

Fig. 1. Shaking Table.

(Designed by Professors B. Mano and A. Inokuti.)

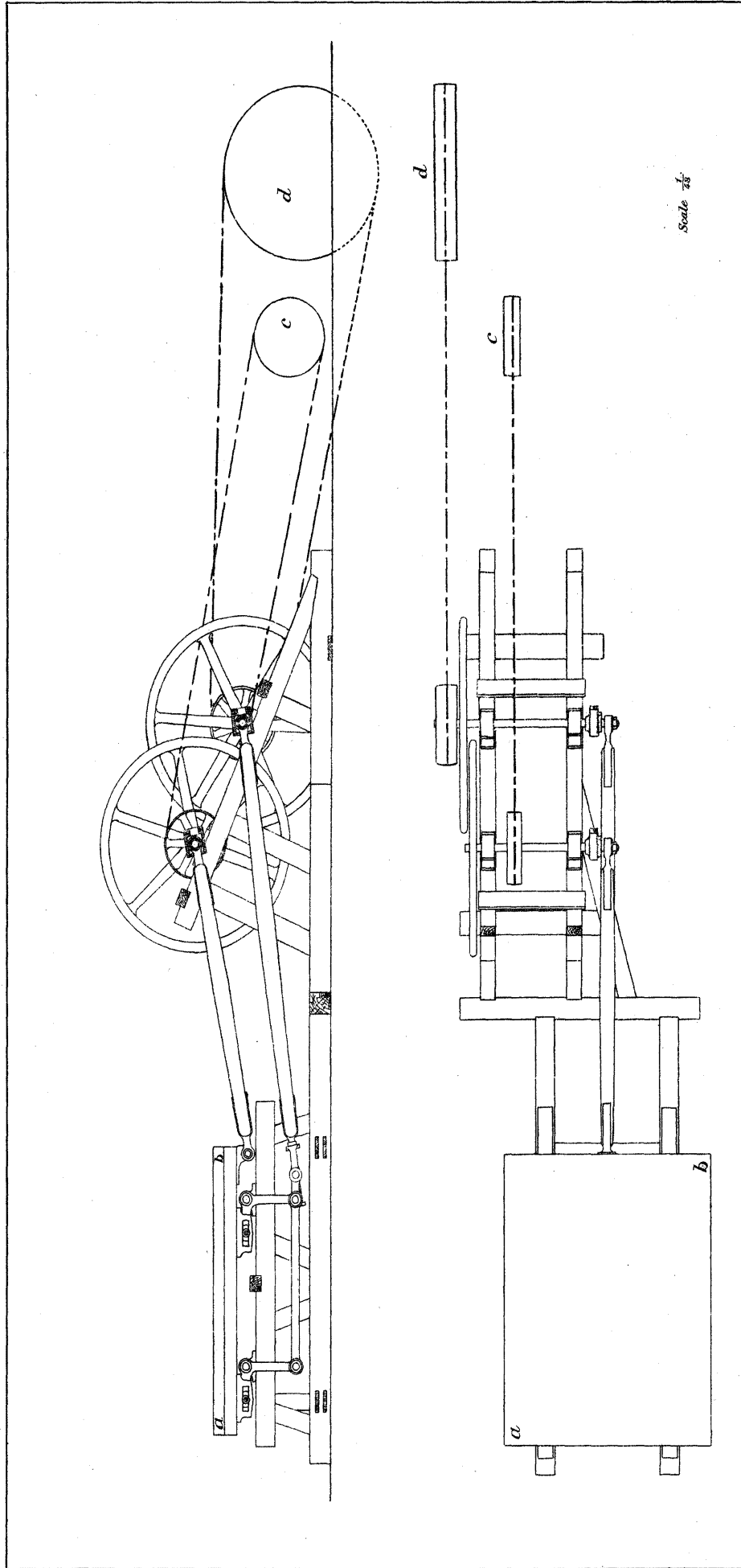

a b is the shaking table, which can be moved horizontally and vertically by means of the two steam engines c and d. (The figures are reproduced from Prof. Mano's report on the shaking table. Vol. XXI of the Report of this Committee.)

Fig. 2. Record-receiver.

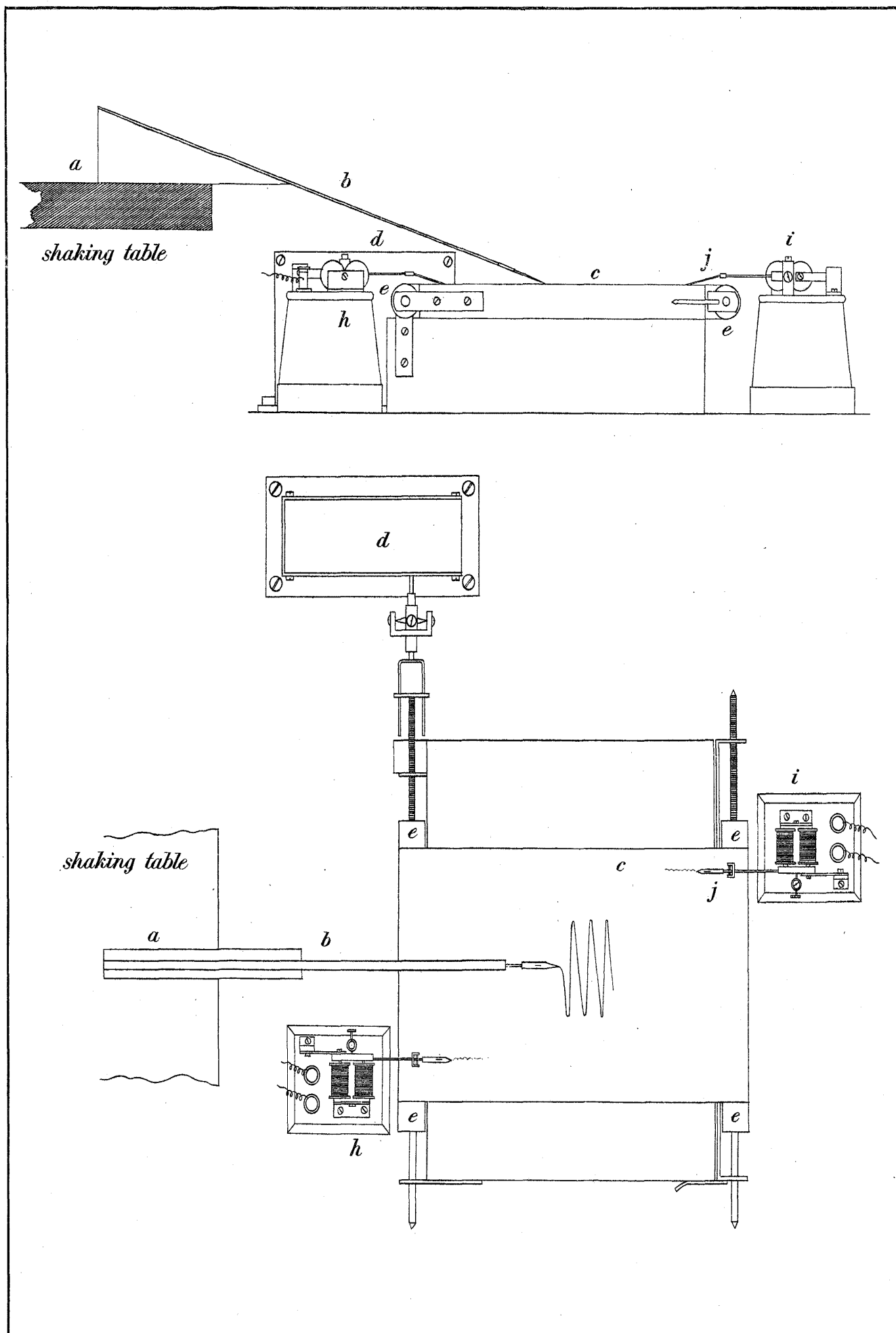

Fig. 3. Time-Marking Pendulum.

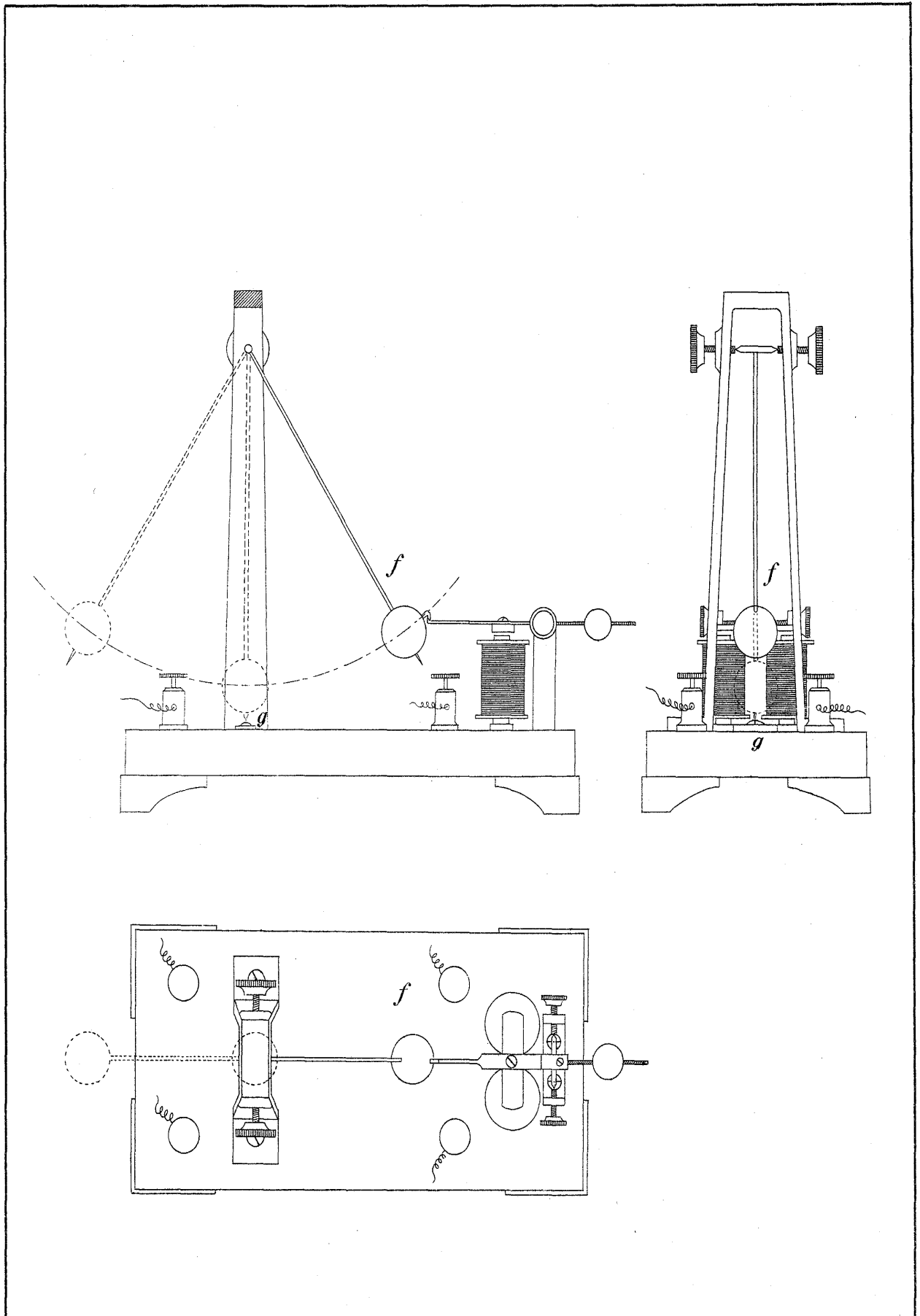

Fig. 4. Brick Columns.

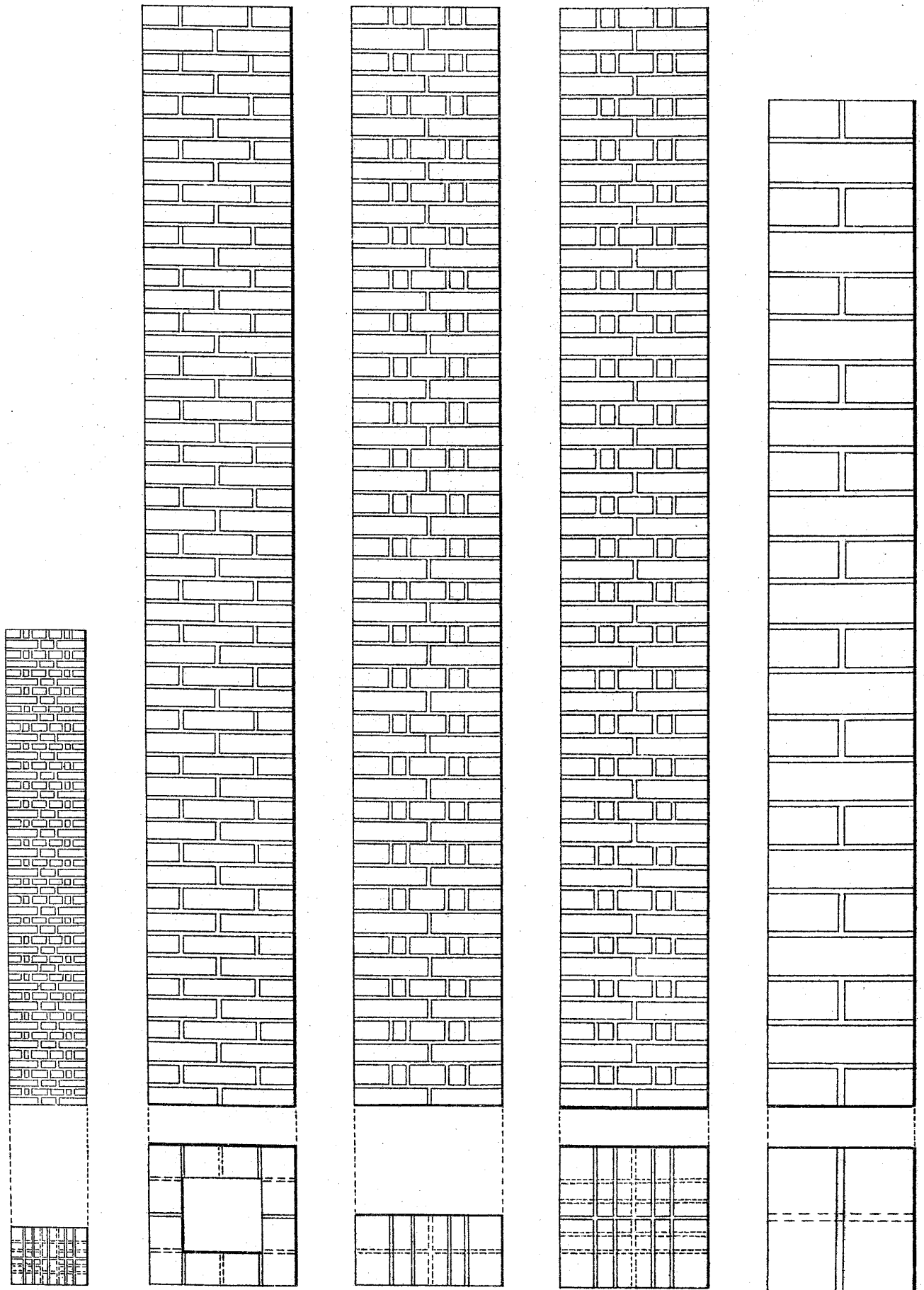

Fig. 5. Brick Column With Concrete Base.

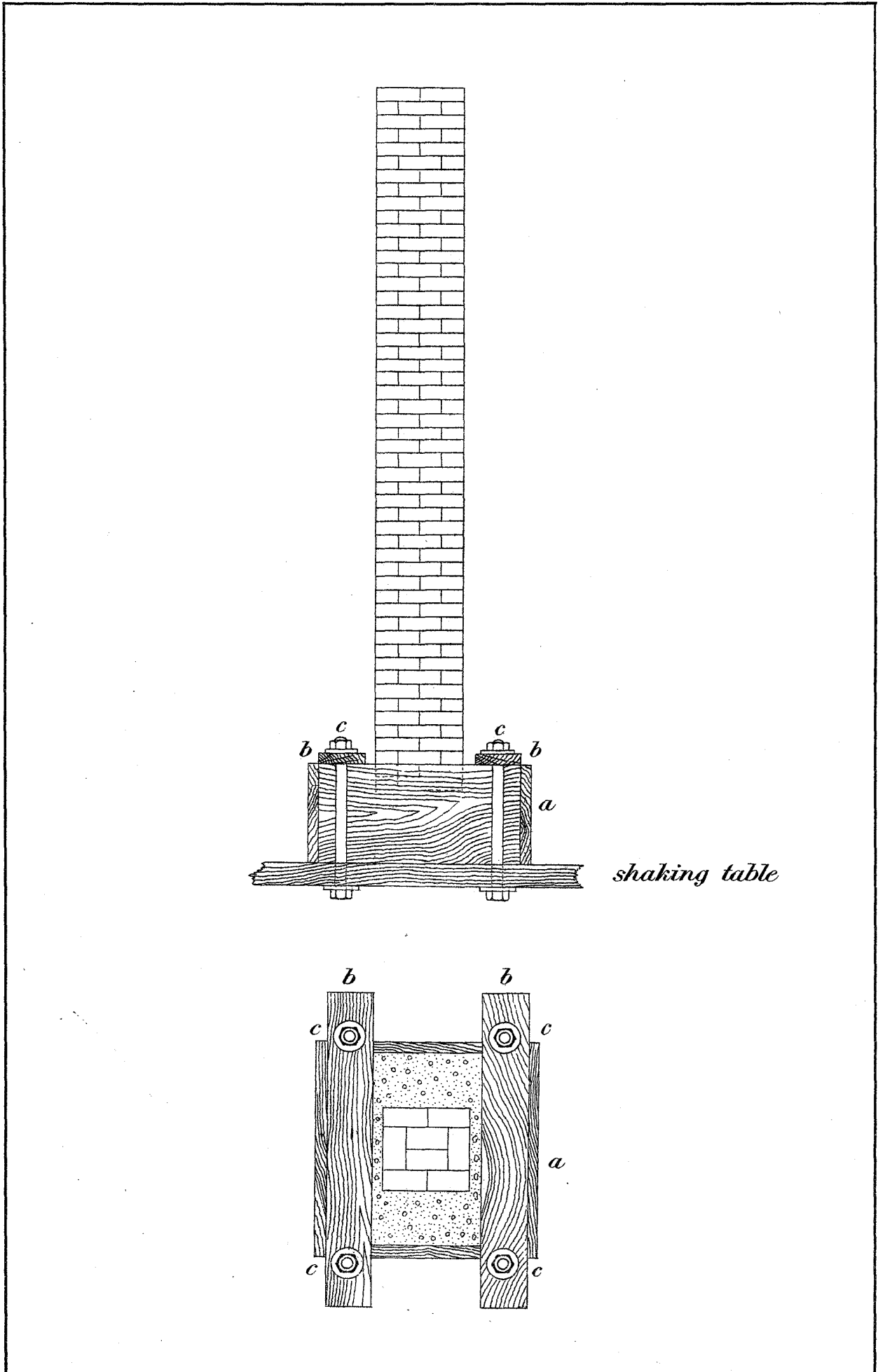

Fig. 6. Iron Frame for fixing the Columns to the Shaking Table.

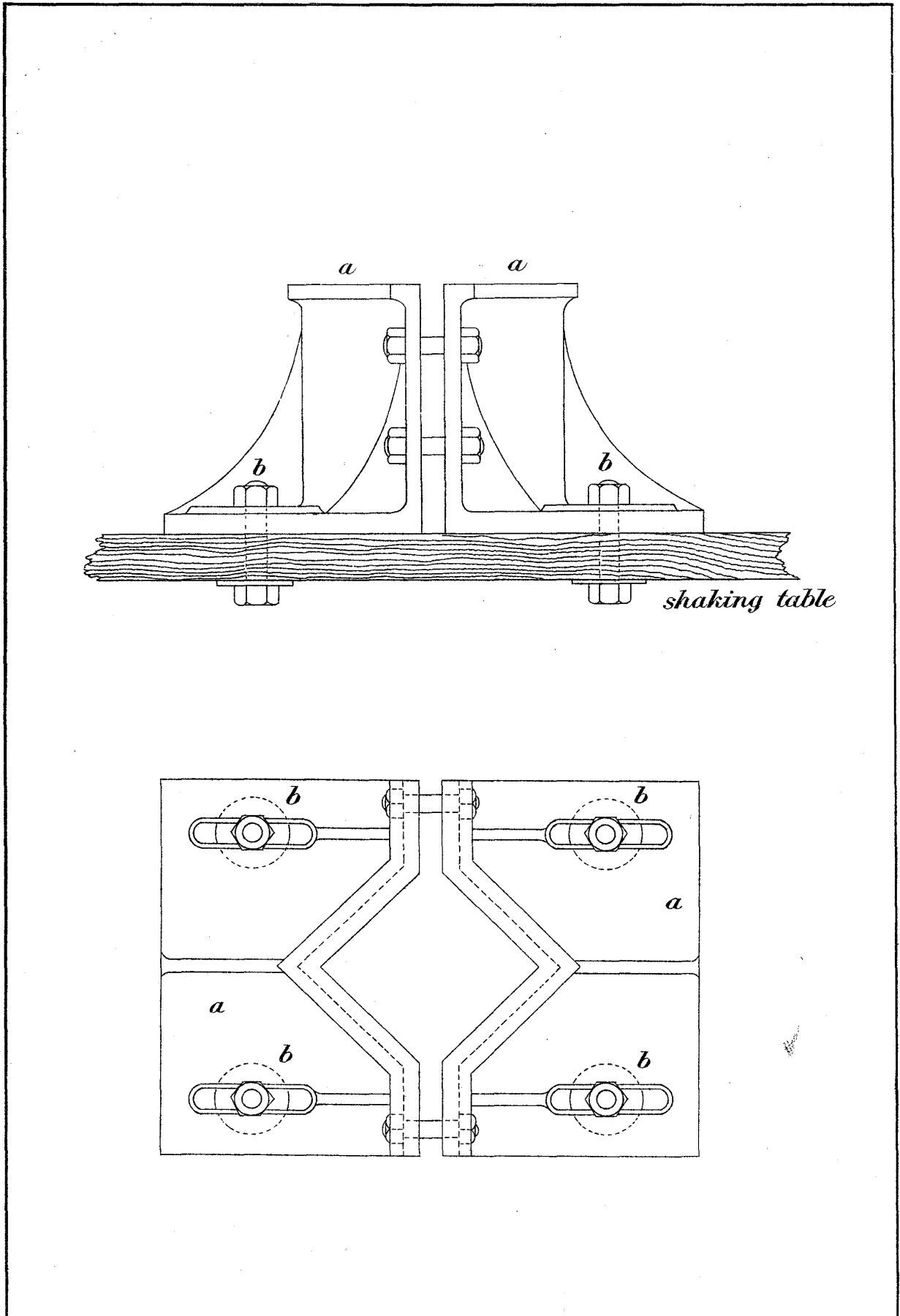
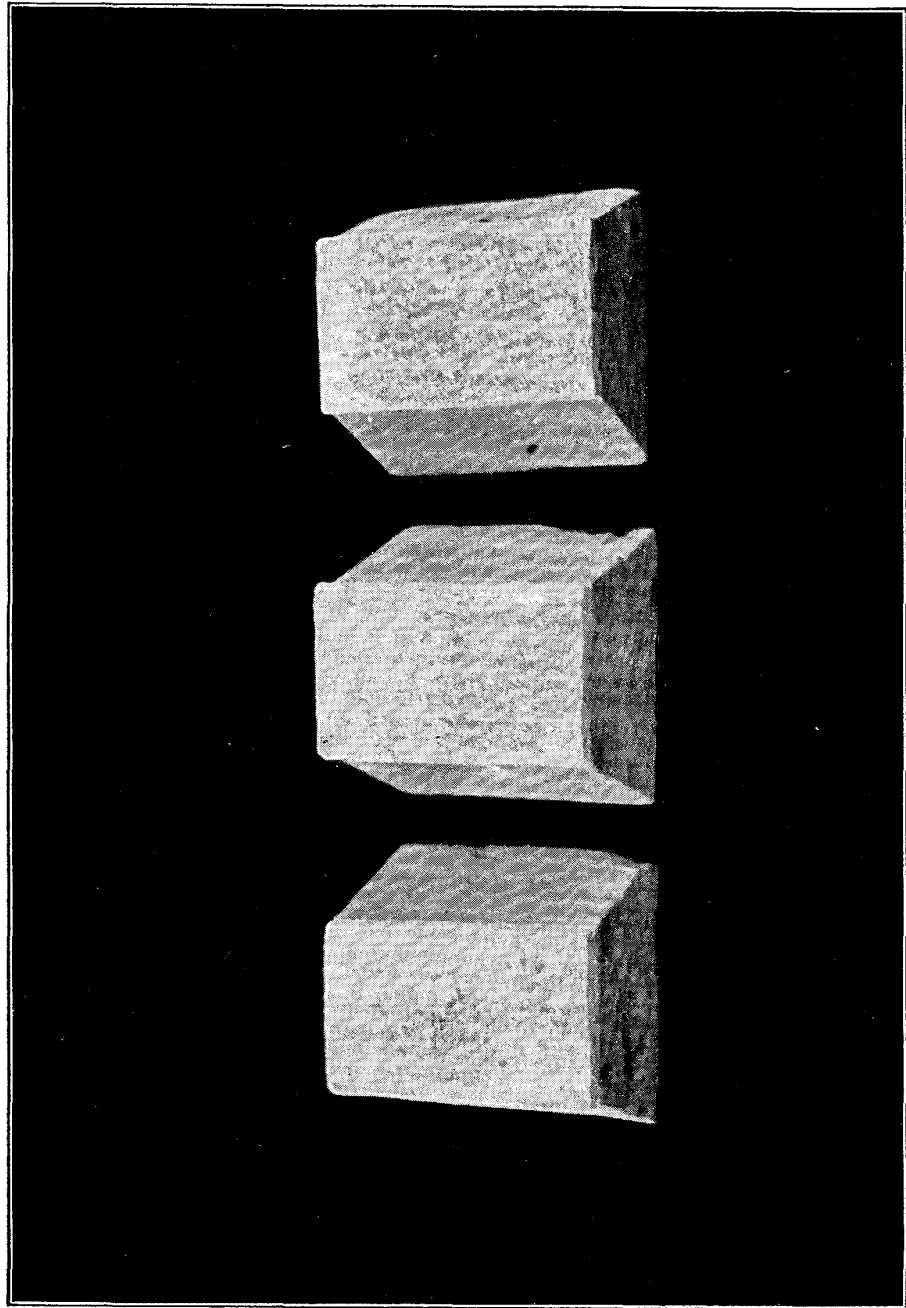

Fig. 7.



(a)

(b)

(c)

Fig. 8.

Fracturing of the Brick Column No. 23.

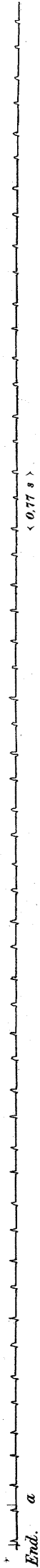

Time: 2 tick-intervals=0.77second.

Motion of the shaking table. (Natural size.)

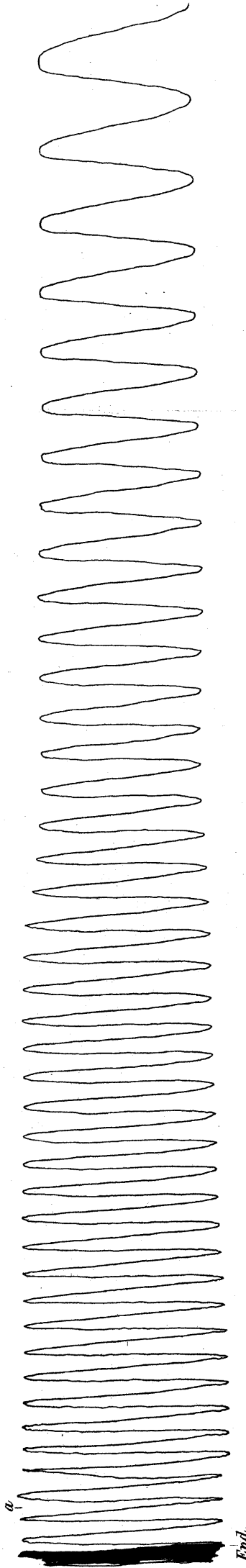

Signal.



The column was fractured at (a).

Fig. 9.

Fracturing of the Brick Column No. 14.

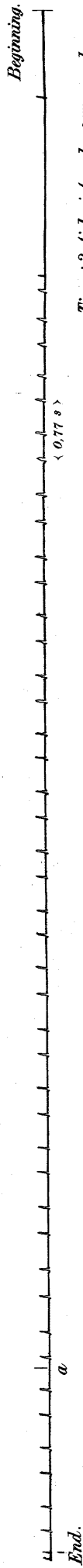

Motion of the shaking table. (Natural size.)

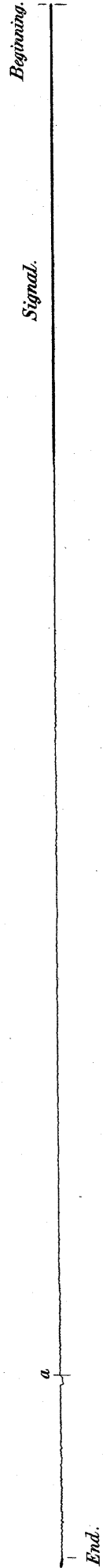
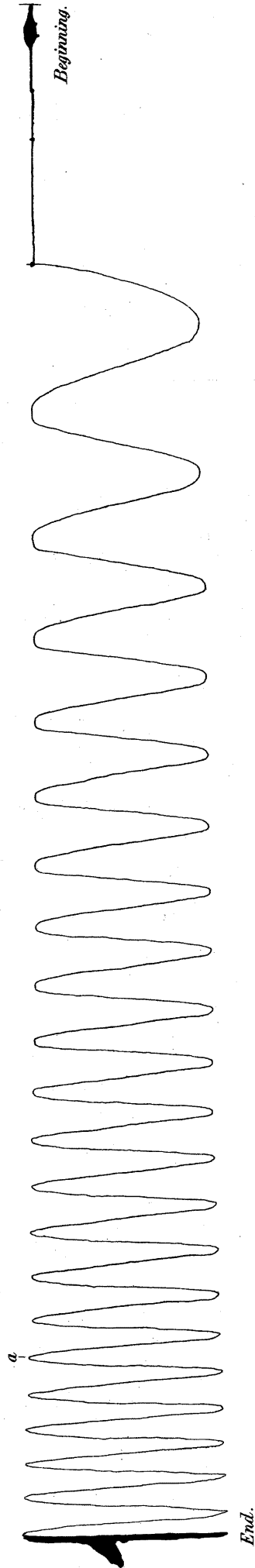

The column was fractured at (a).

Fig. 10.

Fracturing of the Brick Column No. 16" and
the Overturning of the Wooden Column E₃.

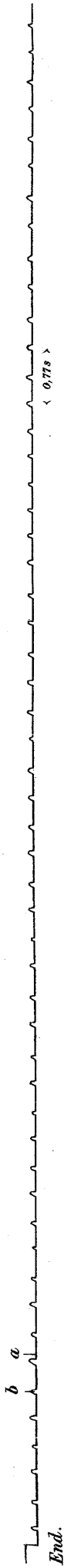

Motion of the shaking table. (Natural size.)

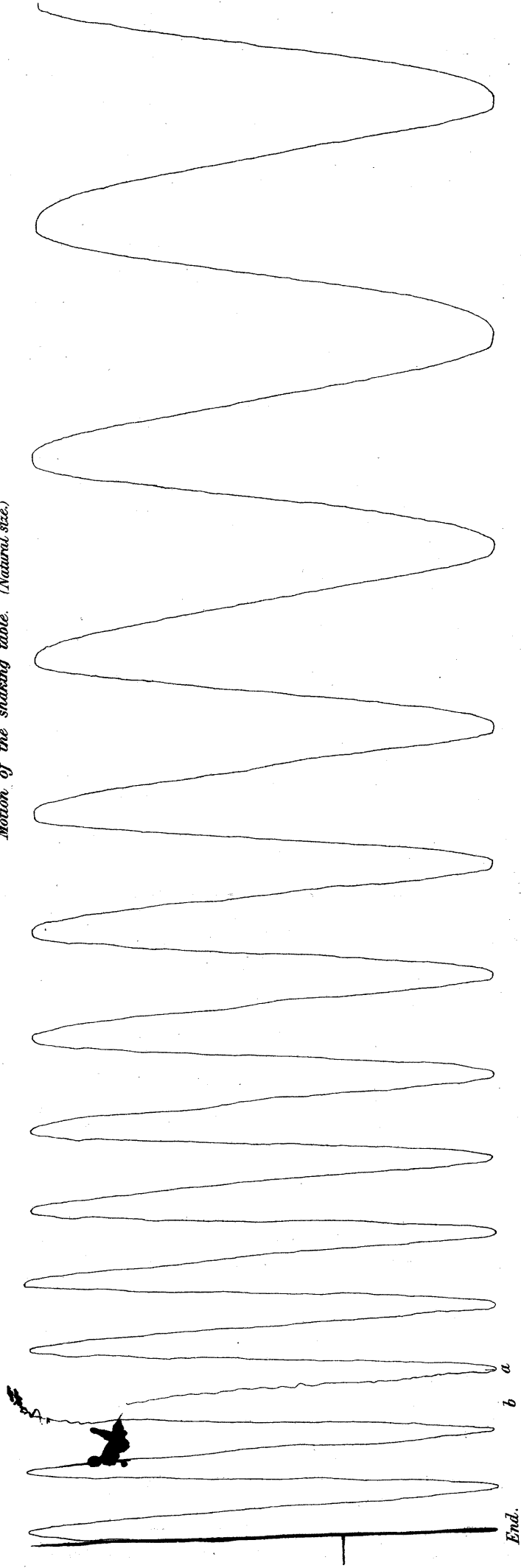

Signal.

b a

End.

The brick column was fractured at (a), and
the wooden column overturned at (b).

Fig. 11.

Fracturing of the Brick Column No. 16^m and
the Overturning of the Wooden Column E₂.

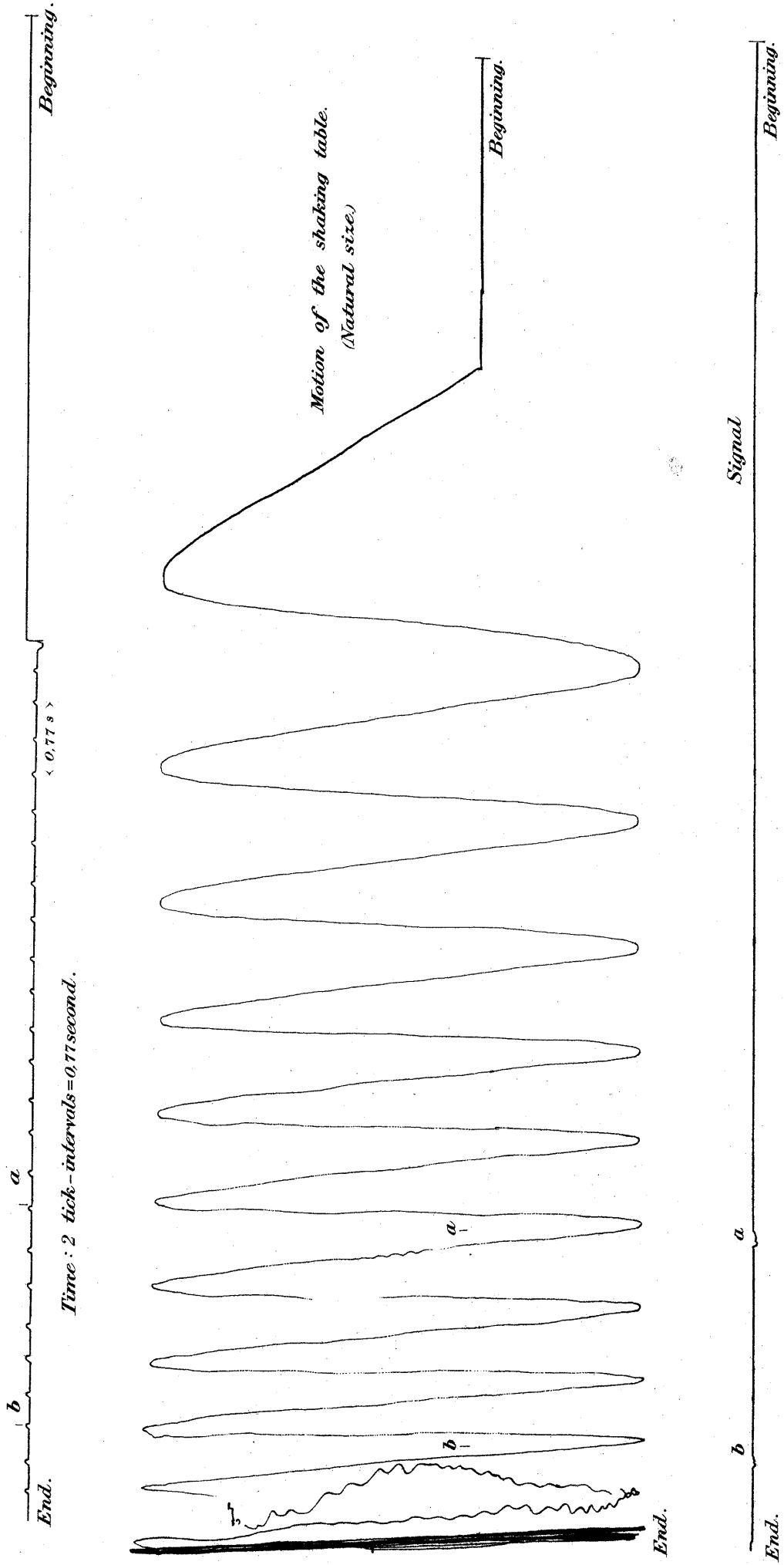

The brick column was fractured at (a), and
the wooden column overturned at (b).

Fig. 12.

Fracturing of the Brick Column No. 18' and
the Overturning of the Wooden Column 6'.



Motion of the shaking table. (Natural size.)

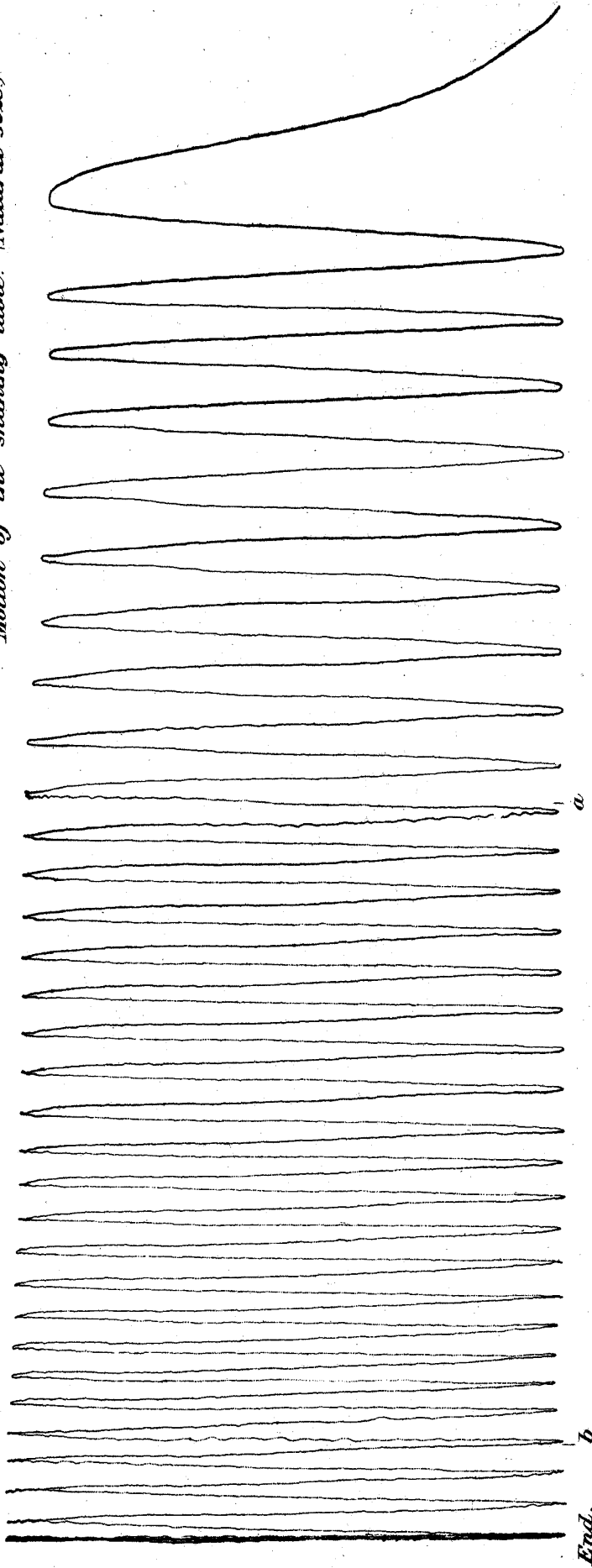

Time: 2 tick-intervals = 0,77 second.

$\langle 0,77 \rangle s$



Signal.

a

b

End.

The brick column was fractured at (b), and
the wooden column overturned at (a).

Fig. 13.

Fracturing of the Brick Column No. 13"

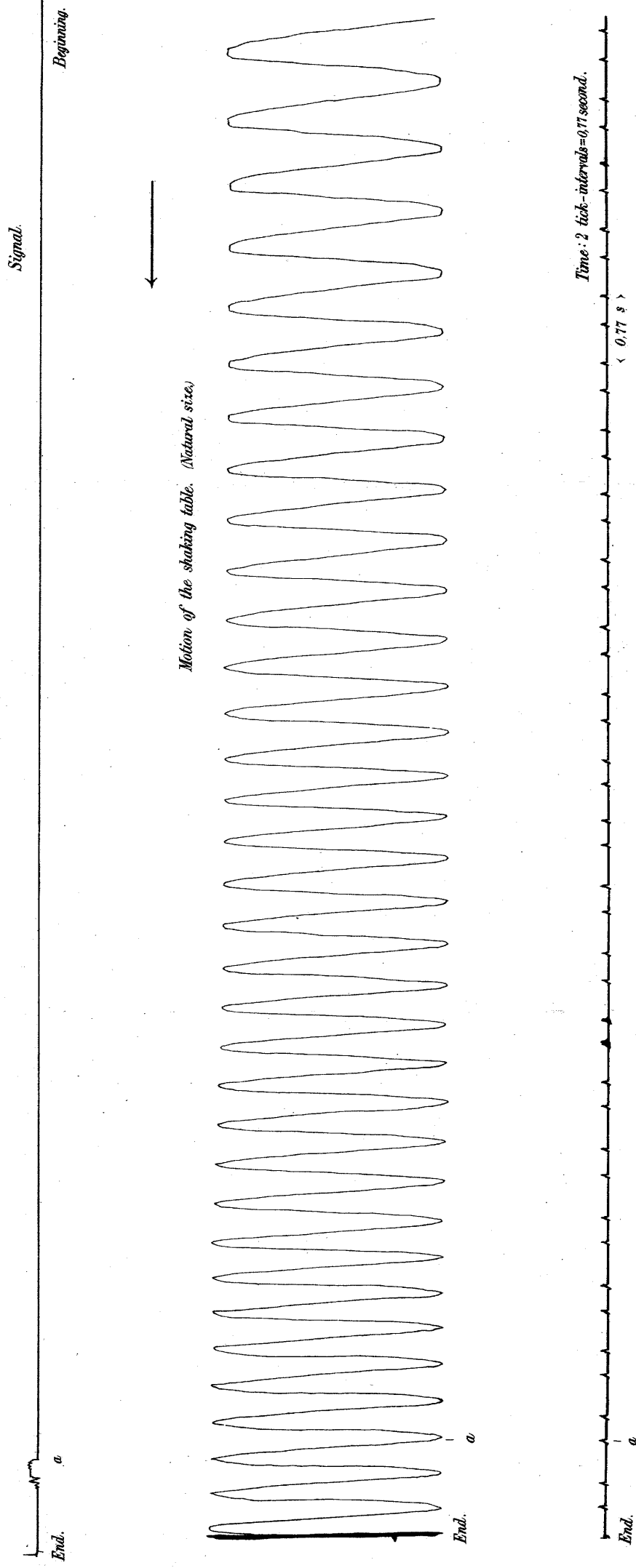

The column was fractured at (a).

Fig. 14.

Fracturing of the Brick Column No. 24.

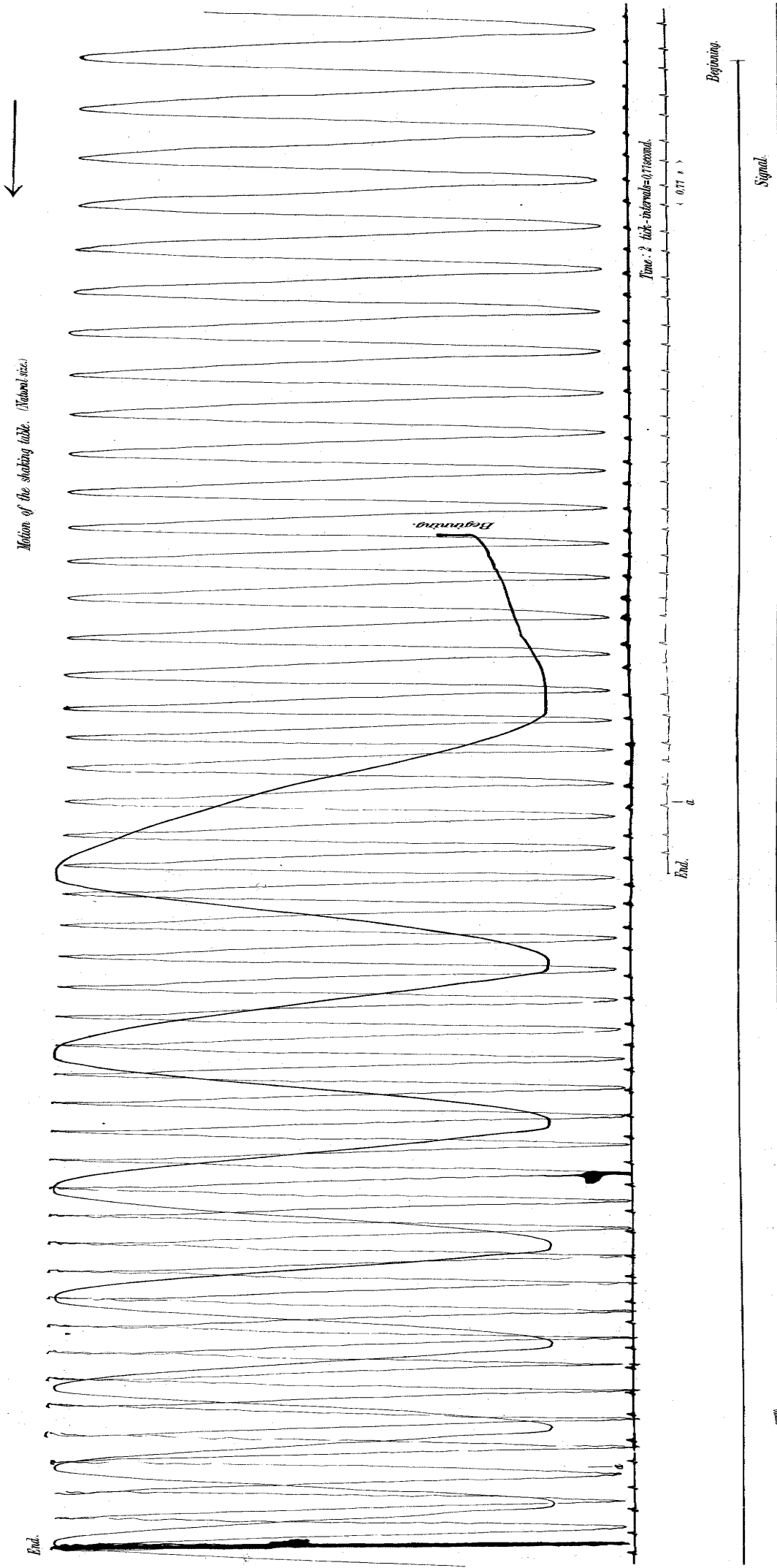
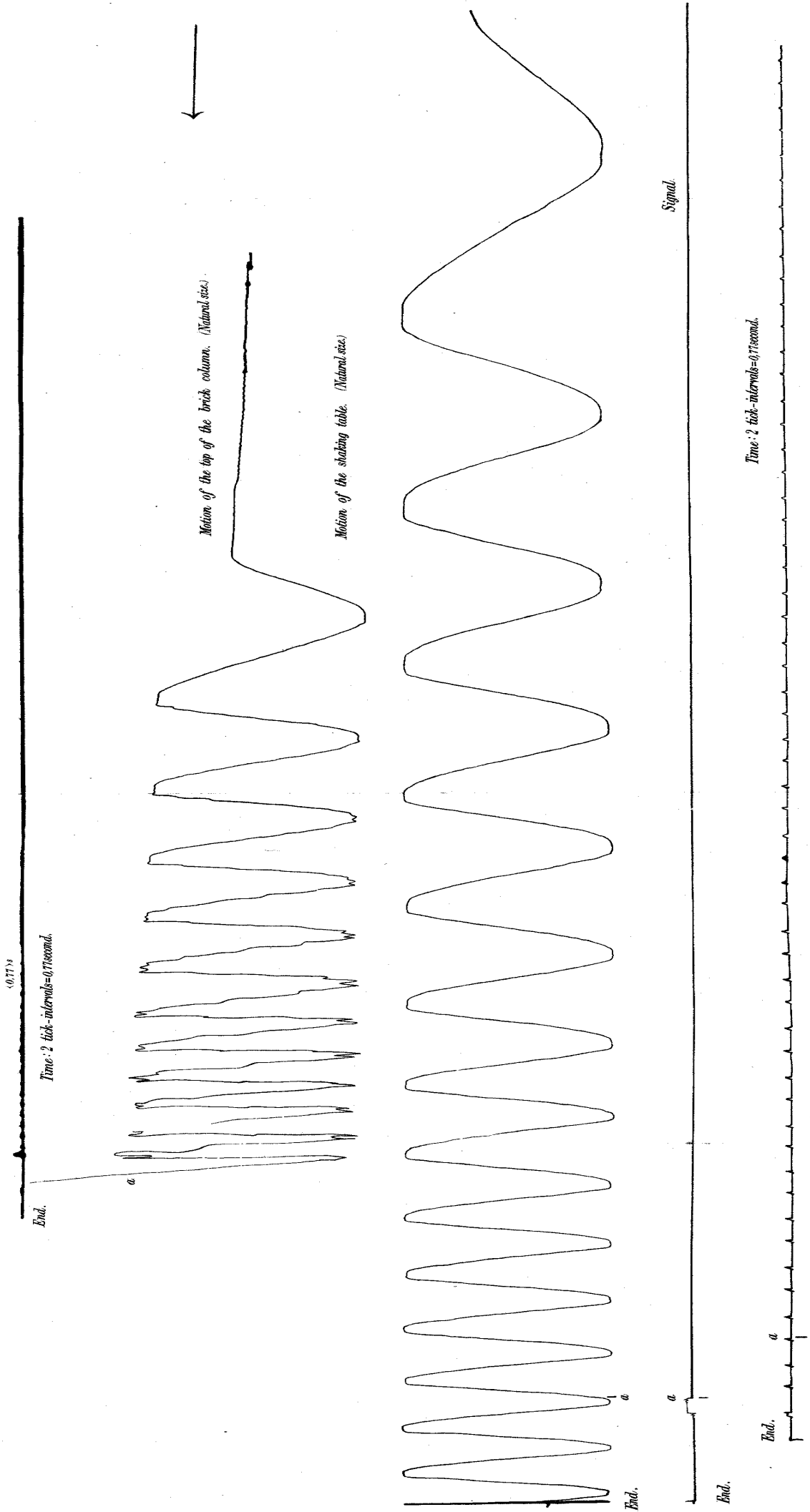

Fig. 15.

Fracturing of the Brick Column No. 13.



The brick column was fractured at (a).

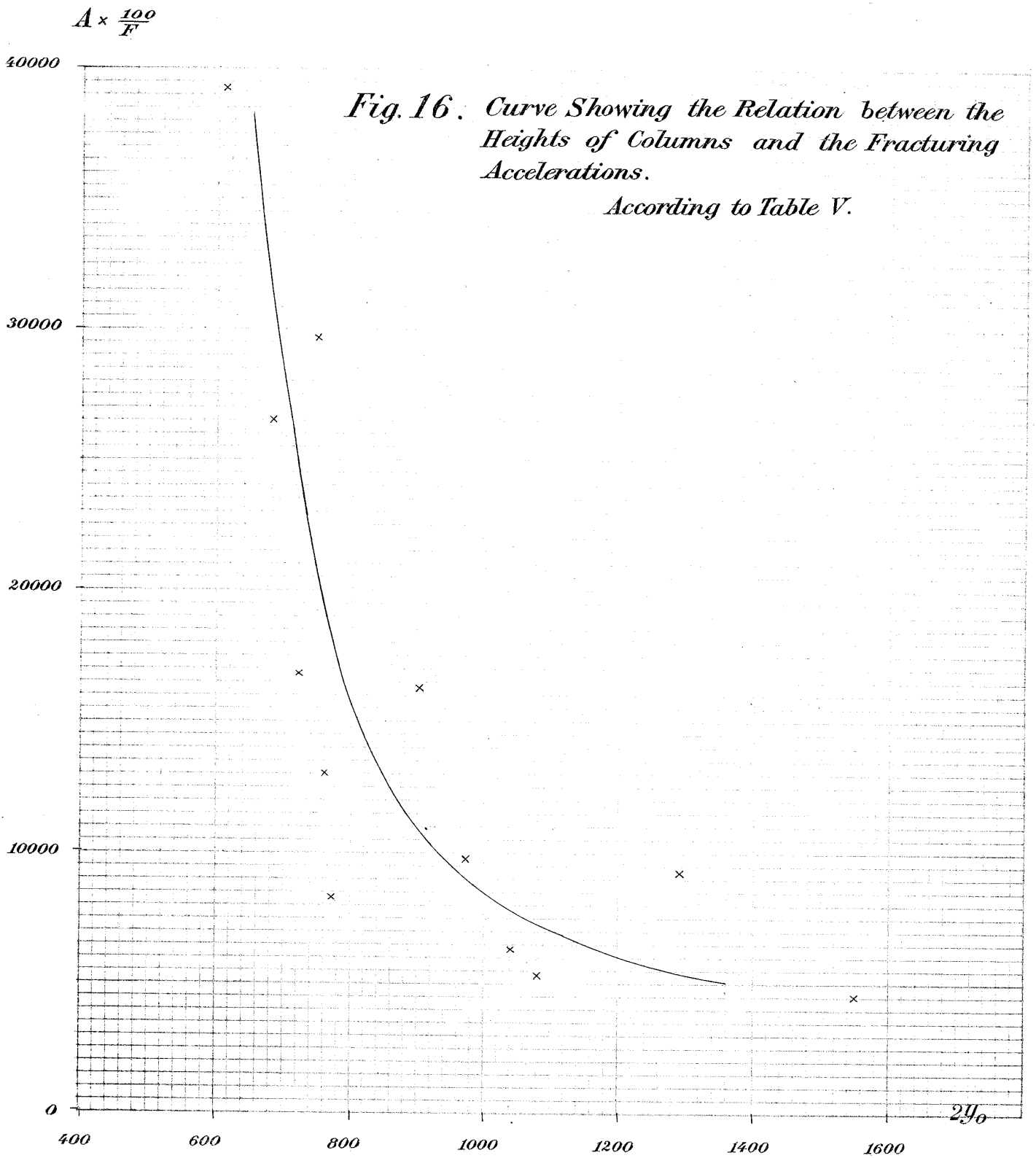
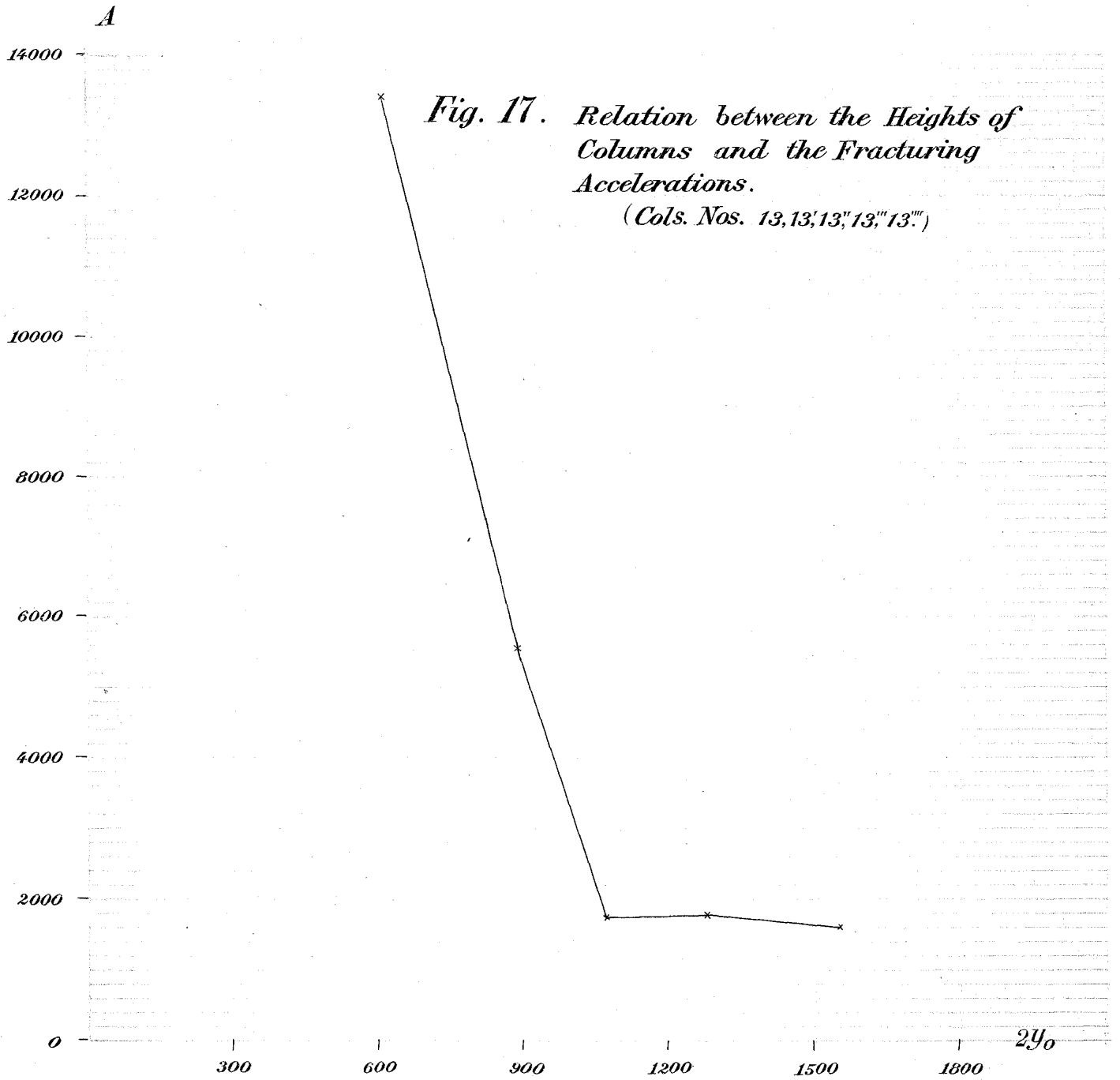

Fig. 16. Curve Showing the Relation between the Heights of Columns and the Fracturing Accelerations.

According to Table V.

$2y_0 =$ height of the column above the section of fracture
 $A \times \frac{100}{F} =$ fracturing acceleration, in mm per sec. per sec.



$2y_0$ = height of the column above the section of fracture
 A = fracturing acceleration, in mm per sec. per sec.

Fig. 18. A Column of Uniform Strength.

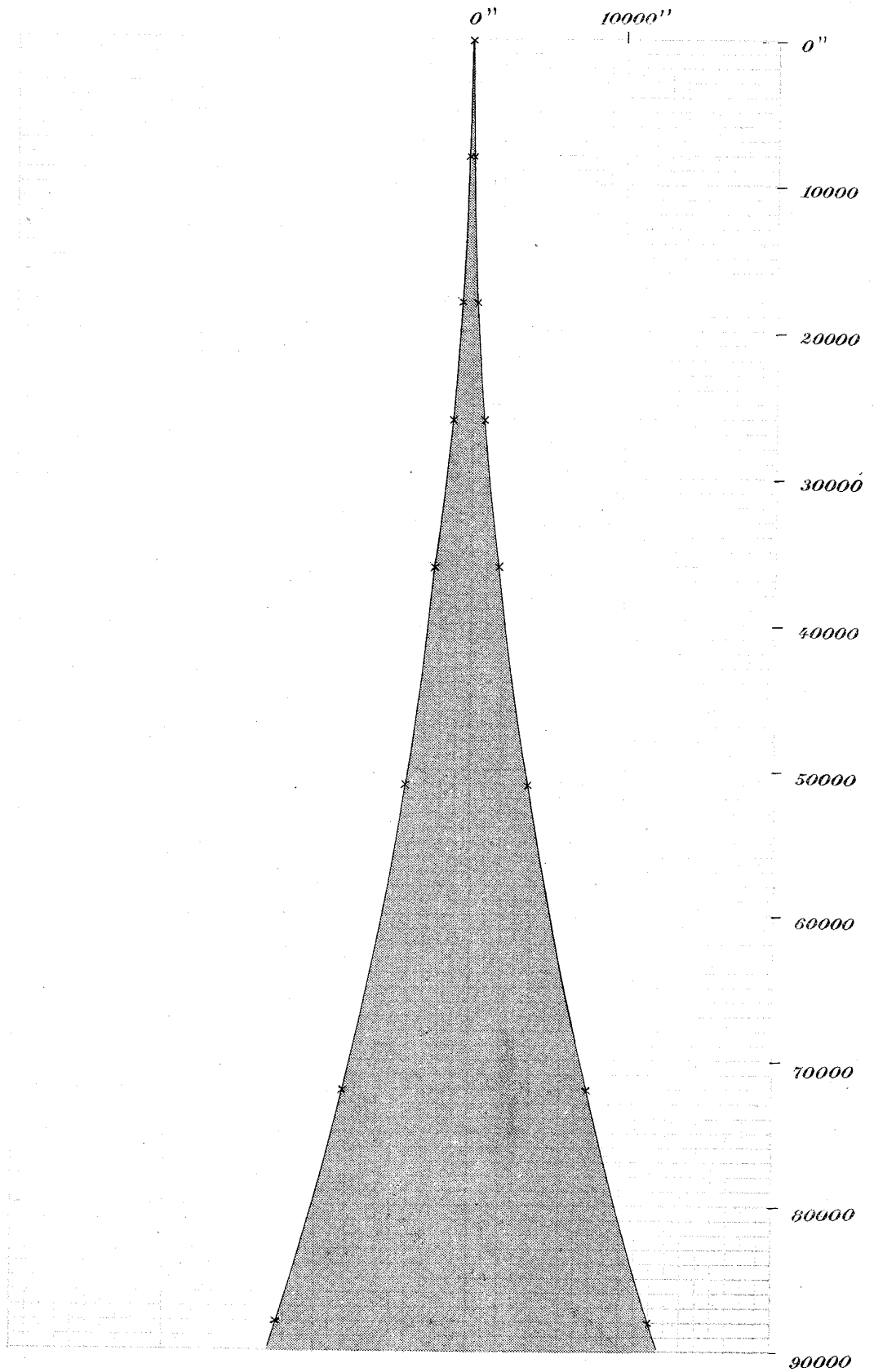

Fig. 19. A Bridge Pier.

Scale

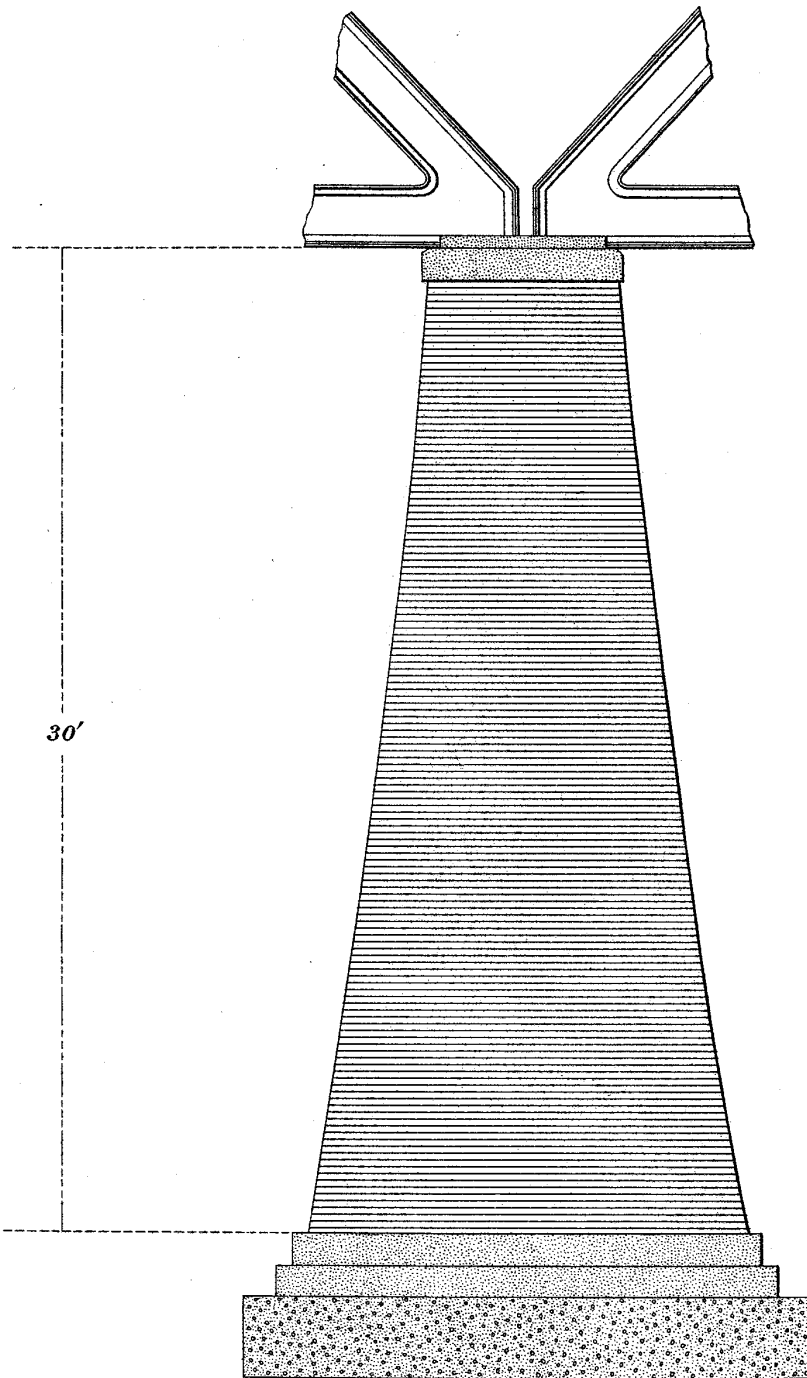
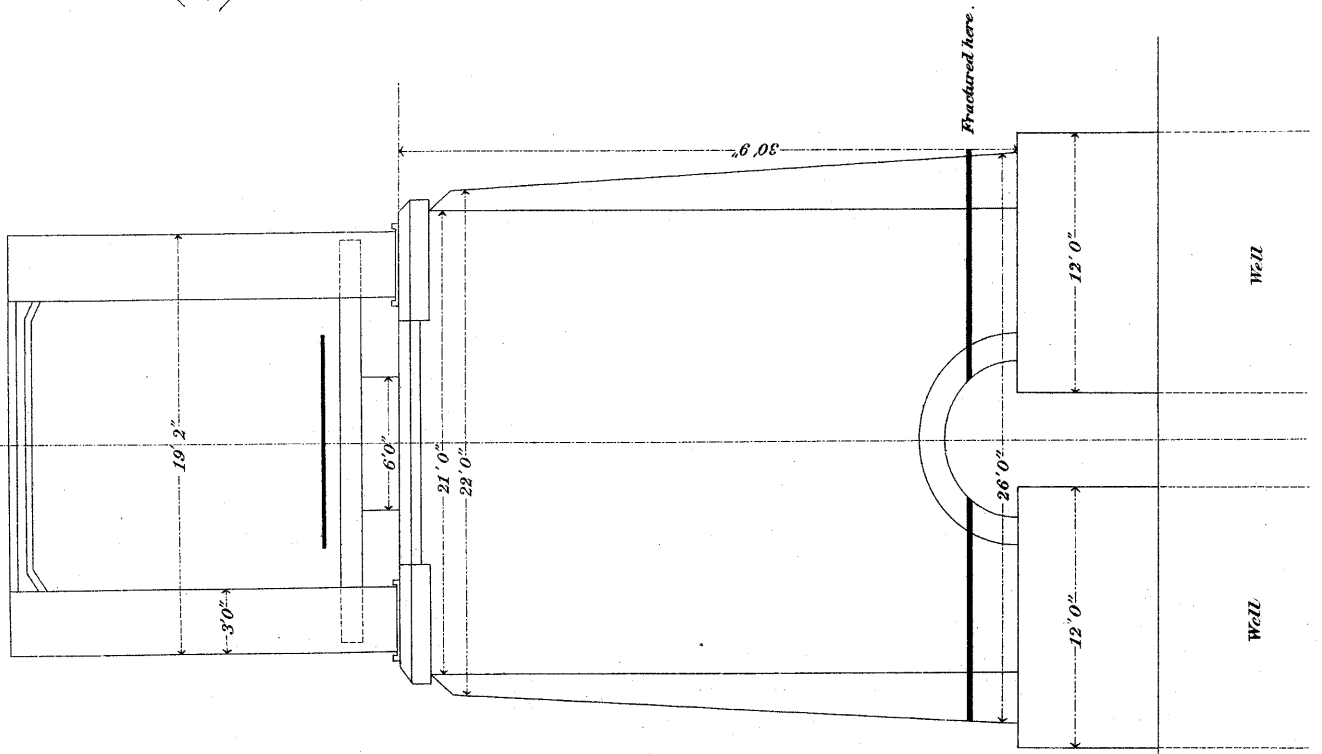

Fig. 20. Pier of the Kiso Railway Bridge.

(Face)



(Elevation.)

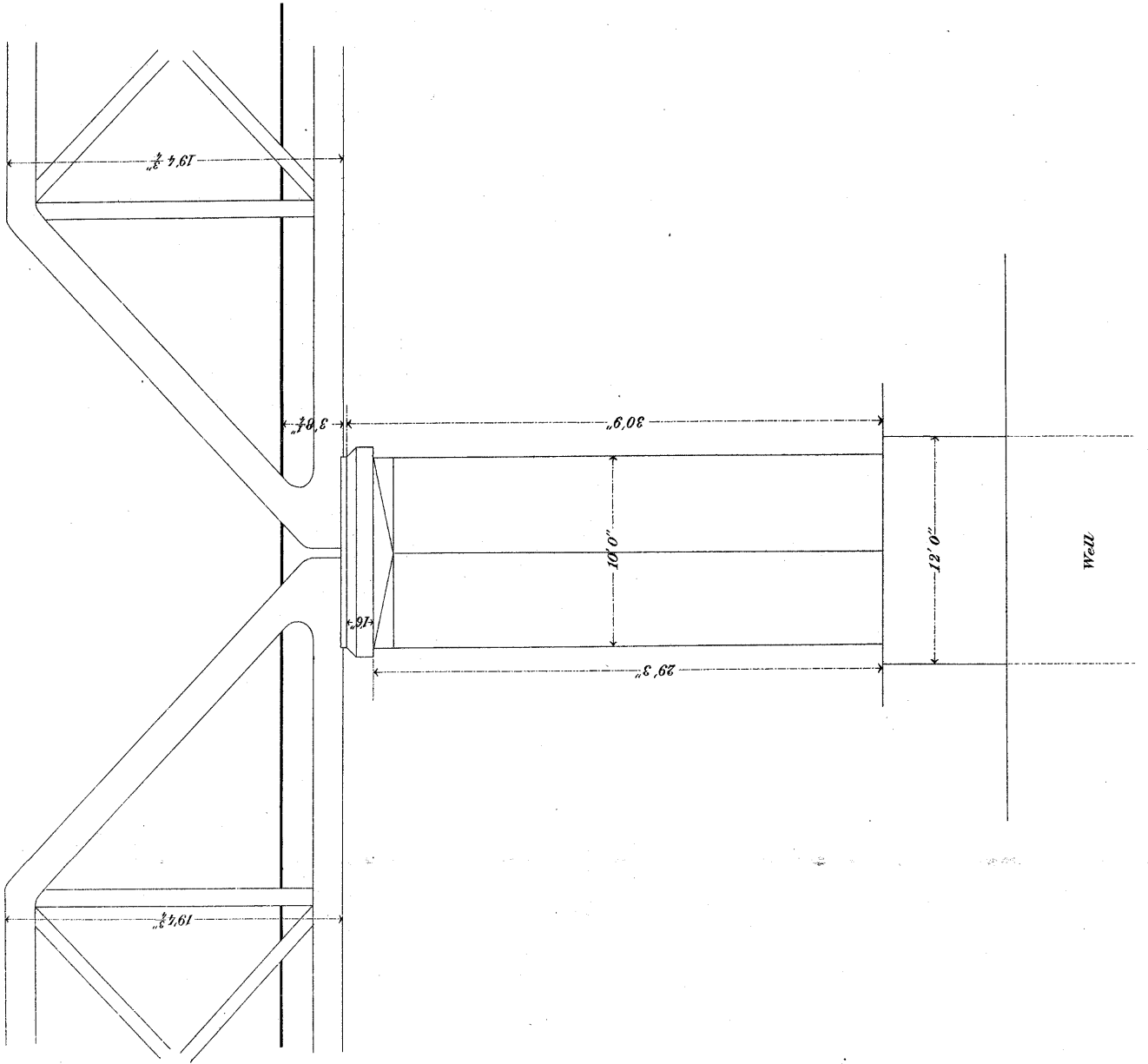
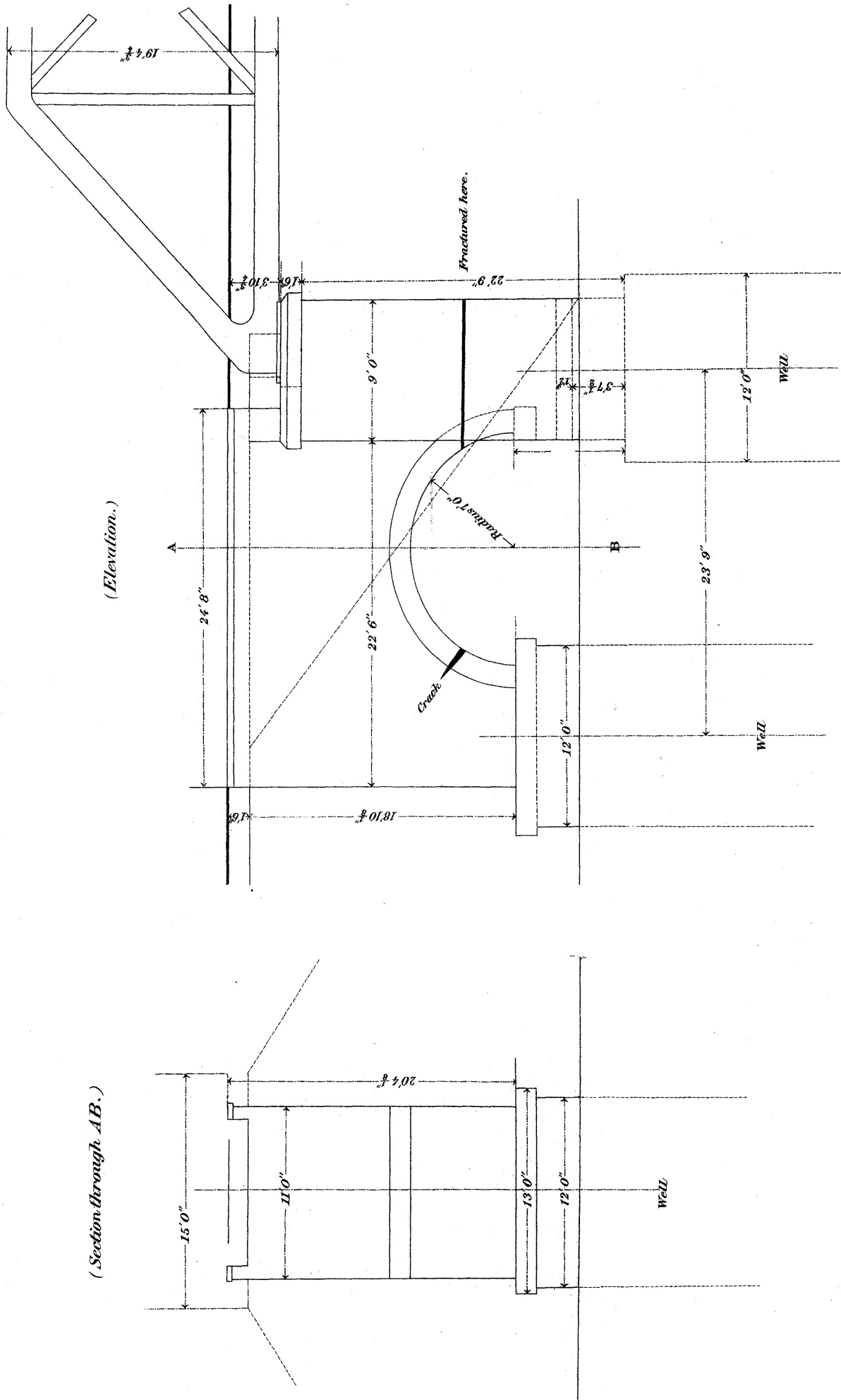

Fig. 21. North Abutment of the Kiso Railway Bridge.



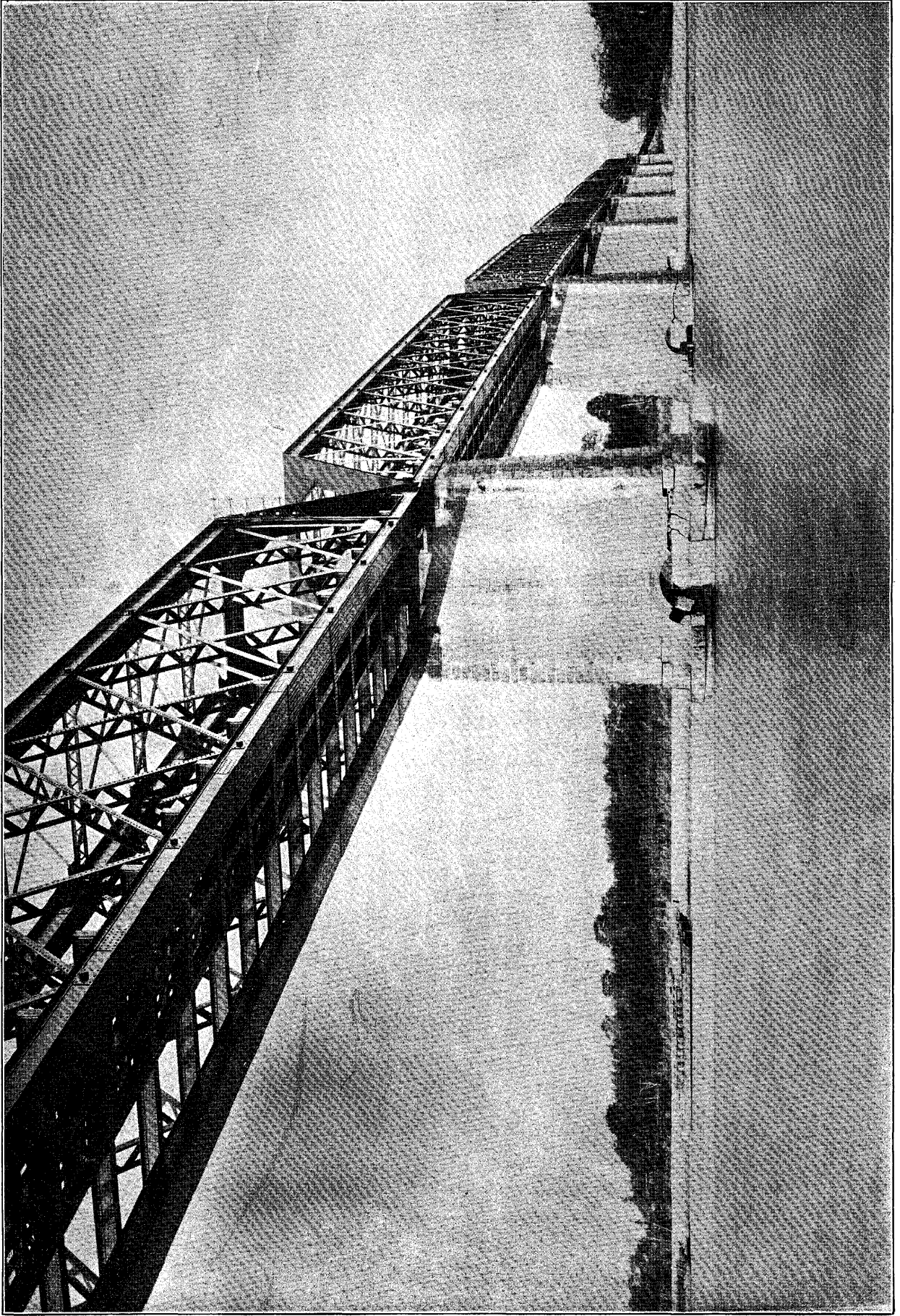

Fig. 22. Kiso-gawa Railway Bridge. Oct. 28, 1891.

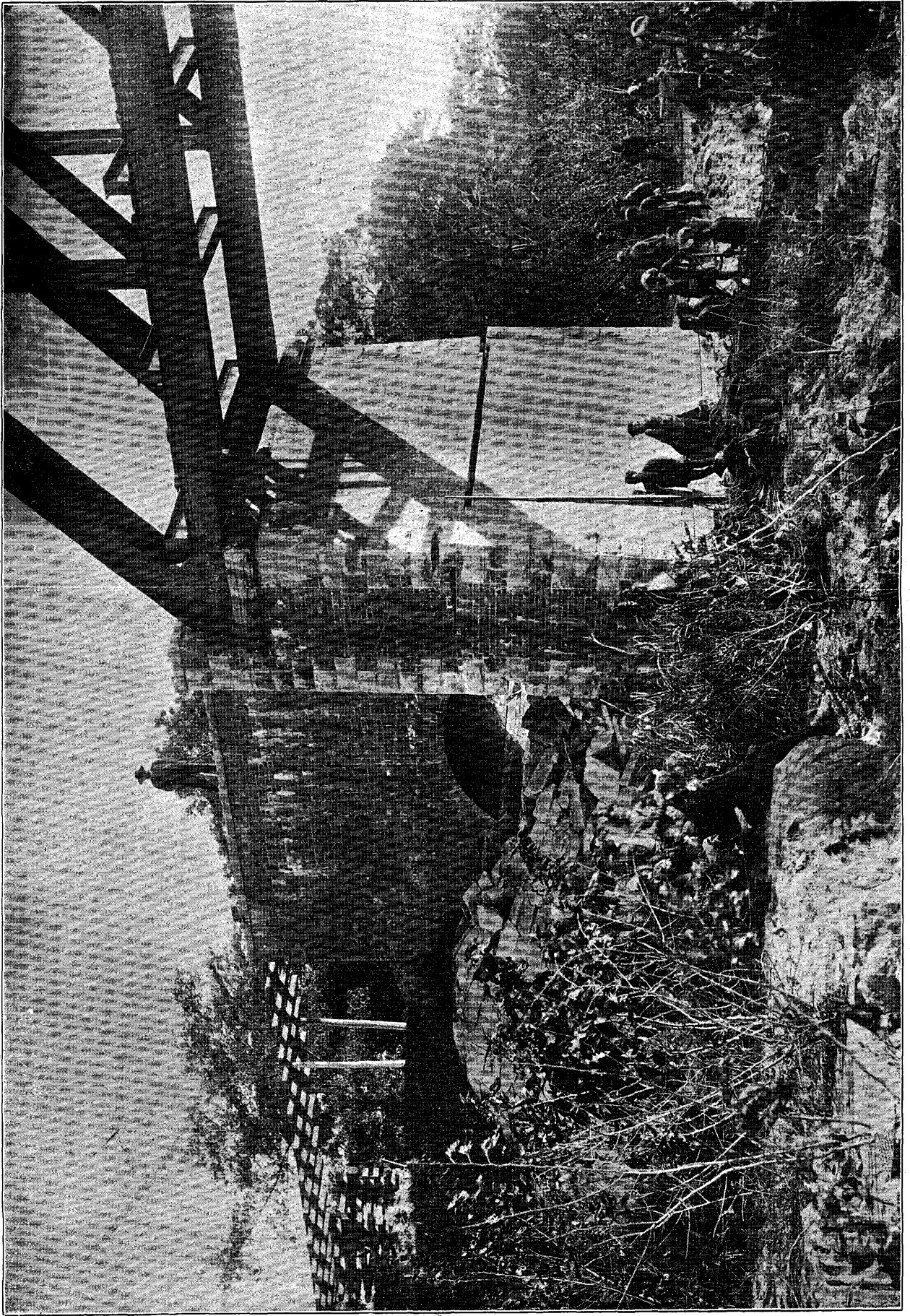
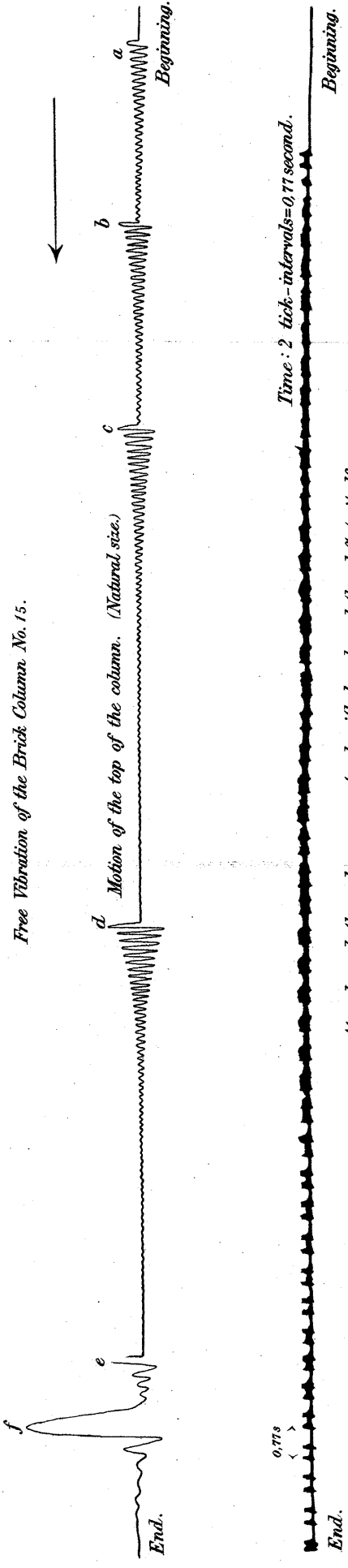

Fig. 23. North Abutment of the Kiso-gawa Railway Bridge. Oct. 28, 1891.

Fig. 24.



At a, b, c, d, the column was struck with hand and then left to itself; f is the rocking of the column.

Fig. 25.

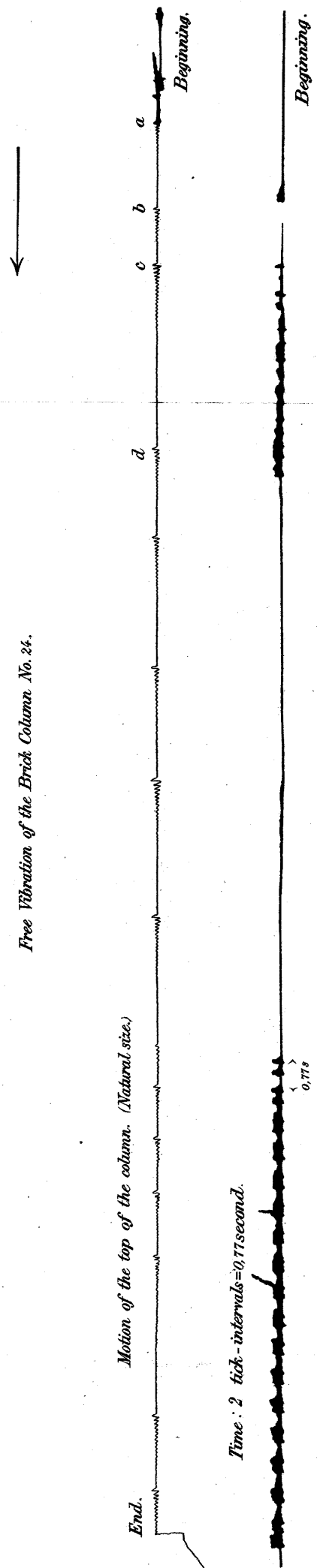

At a, b, c, d, the column was struck with hand and then left to itself.

Fig. 27.

Free Vibration and Fracturing of the Brick Column No. 13.



The column fractured here.

Motion of the top of the brick column. (Natural size.)

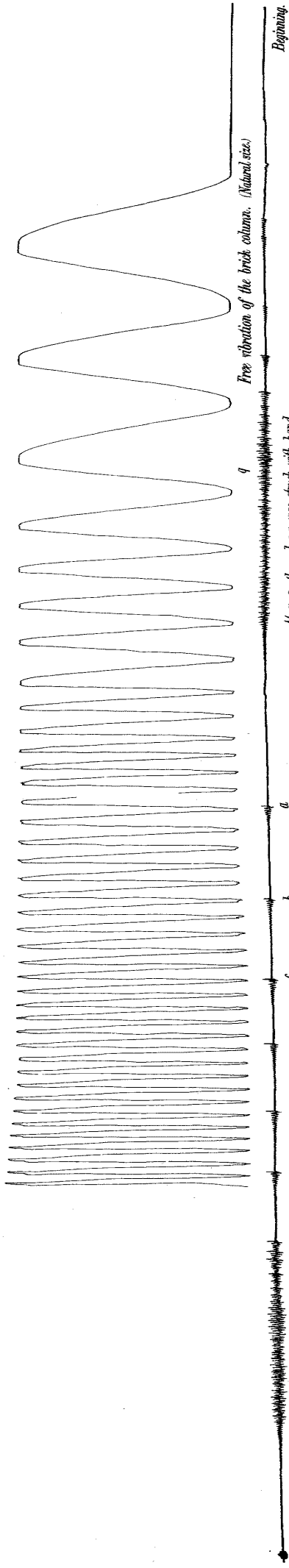

At a, b, c, the column was struck with hand and then left to itself.

At p, q, the column was struck with hand continuously and irregularly.

Fig. 26.

Free Vibration of the Brick Column No. 13.

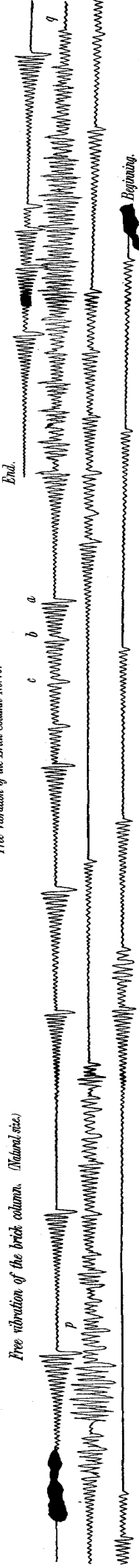

Time: 2 tick-intervals=0.177 second.

(0.177)

At a, b, c, ... the column was struck with hand and then left to itself.

At p, q, ... the column was struck with hand continuously and irregularly.

Fig. 28. Chimney of Oji Goryokyoku Factory.

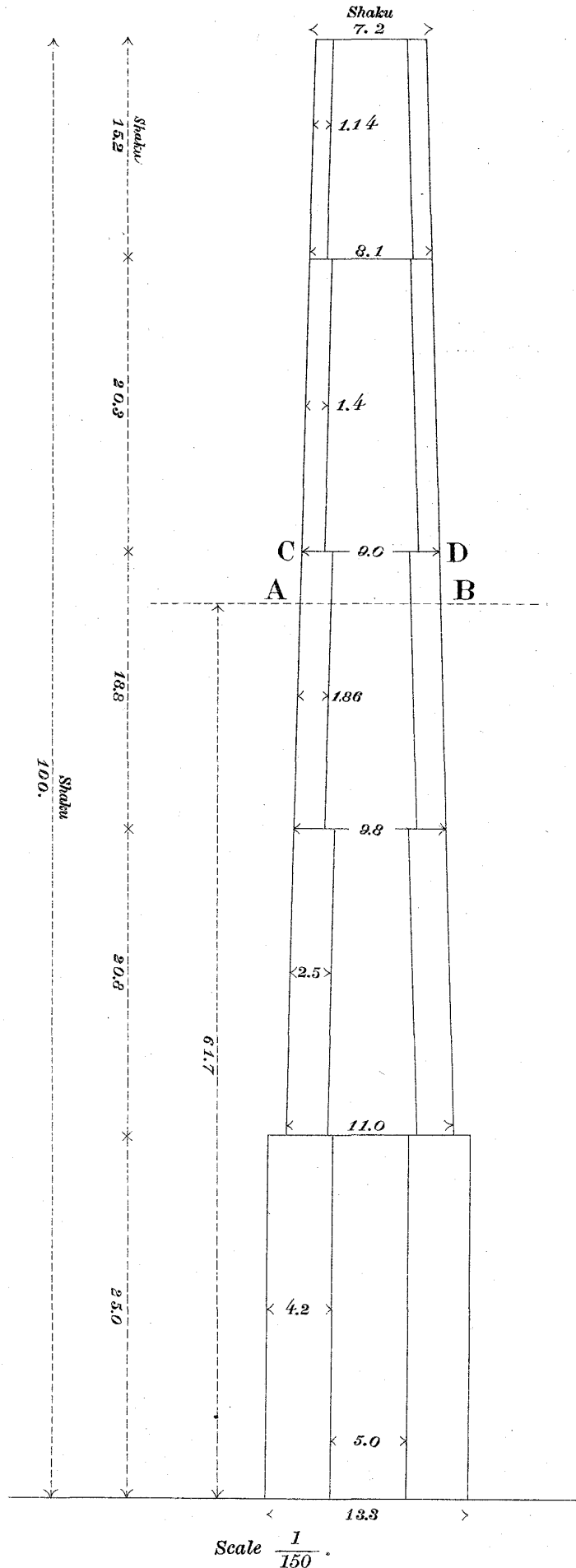

(AB—Section of fracture.)

Fig. 29. The Great Chimney of the Imperial Steel Works.

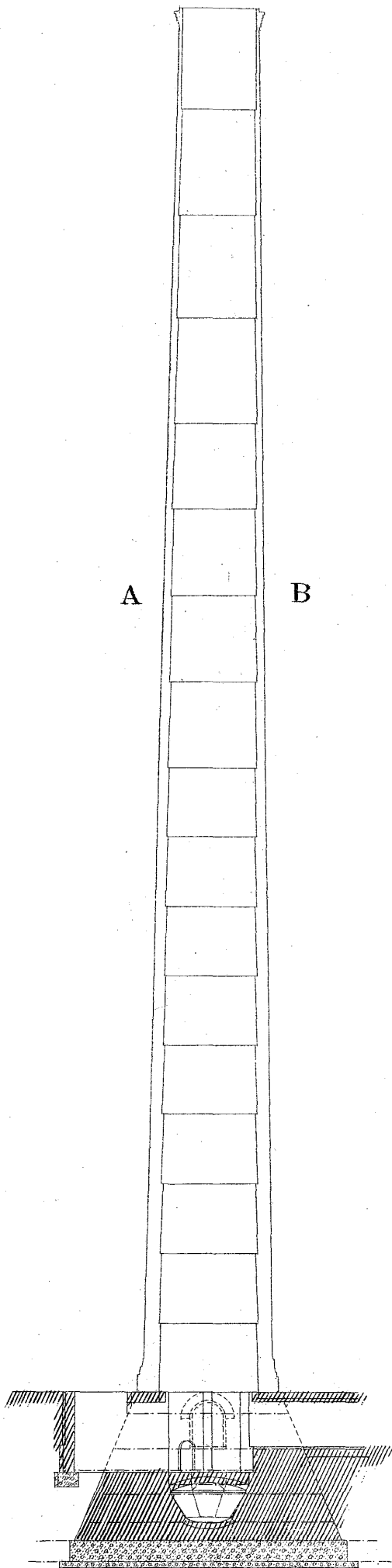

Structure of the Chimney.

Height.	Thickness of brick work.
m	m
80	4,000
74	$\frac{4,216}{4,116}$
68	$\frac{4,332}{4,292}$
62	$\frac{4,508}{4,448}$
56	$\frac{4,665}{4,605}$
41	$\frac{4,785}{4,665}$
46	$\frac{4,865}{4,785}$
41	$\frac{4,965}{4,905}$
36	$\frac{5,085}{4,965}$
32	$\frac{5,110}{4,990}$
28	$\frac{5,134}{5,014}$
24	$\frac{5,158}{5,058}$
20	$\frac{5,202}{5,122}$
16	$\frac{5,266}{5,166}$
12	$\frac{5,311}{5,211}$
8	$\frac{5,355}{5,215}$
4	$\frac{5,359}{5,190}$
1.5	$\frac{5,290}{5,190}$
0	$\frac{5,250}{5,372}$

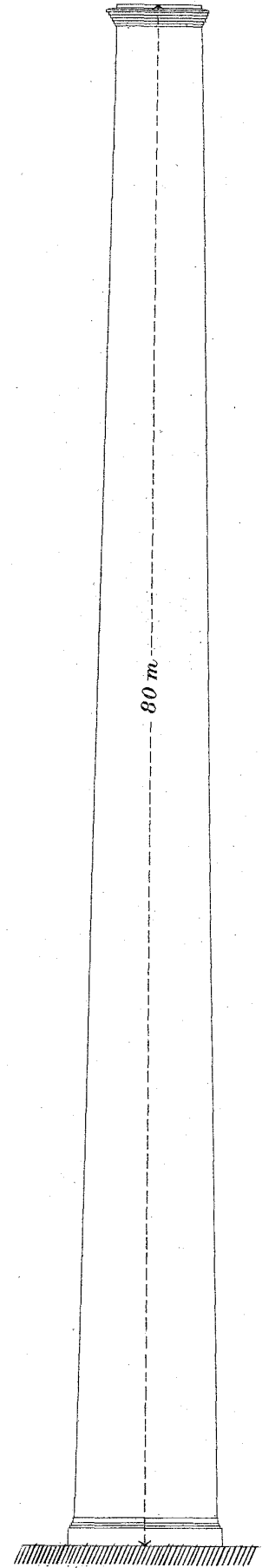

Scale $\frac{1}{400}$

Fig. 30. Wooden Columns.

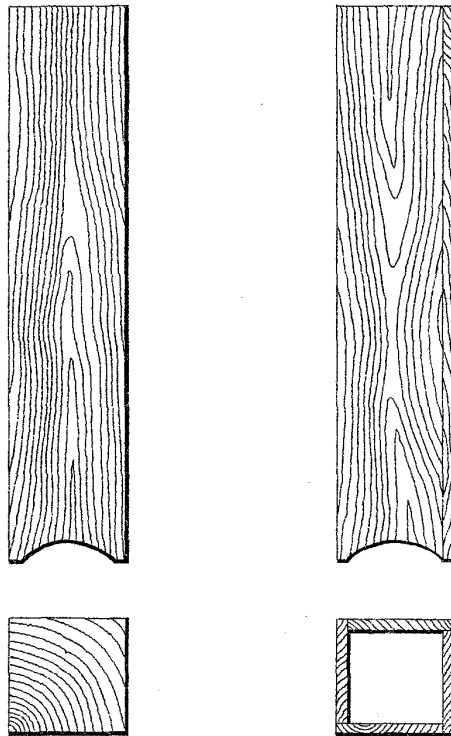
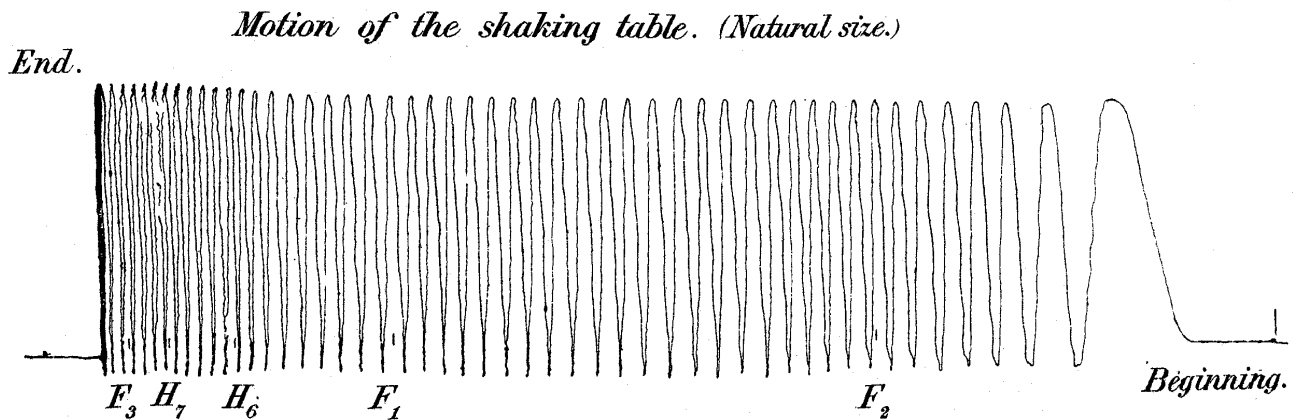
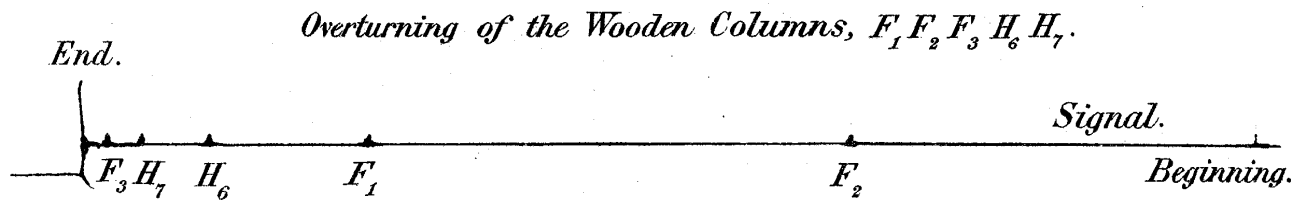
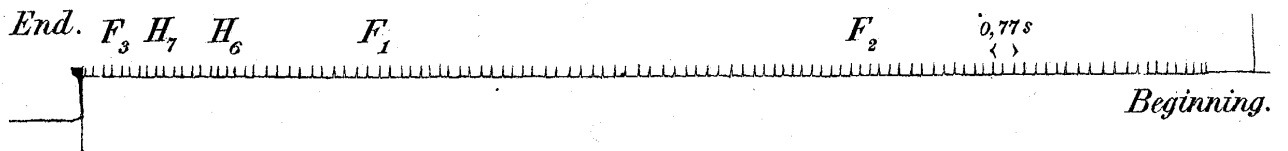

Fig. 31.



Time: 2 tick-intervals = 0,77 second.



The columns were overturned respectively at $F_2 F_1 H_6 H_7$ and F_3 .

Fig. 32.

Overturning of the Wooden Columns E_1, E_2, E_3, E_4 .

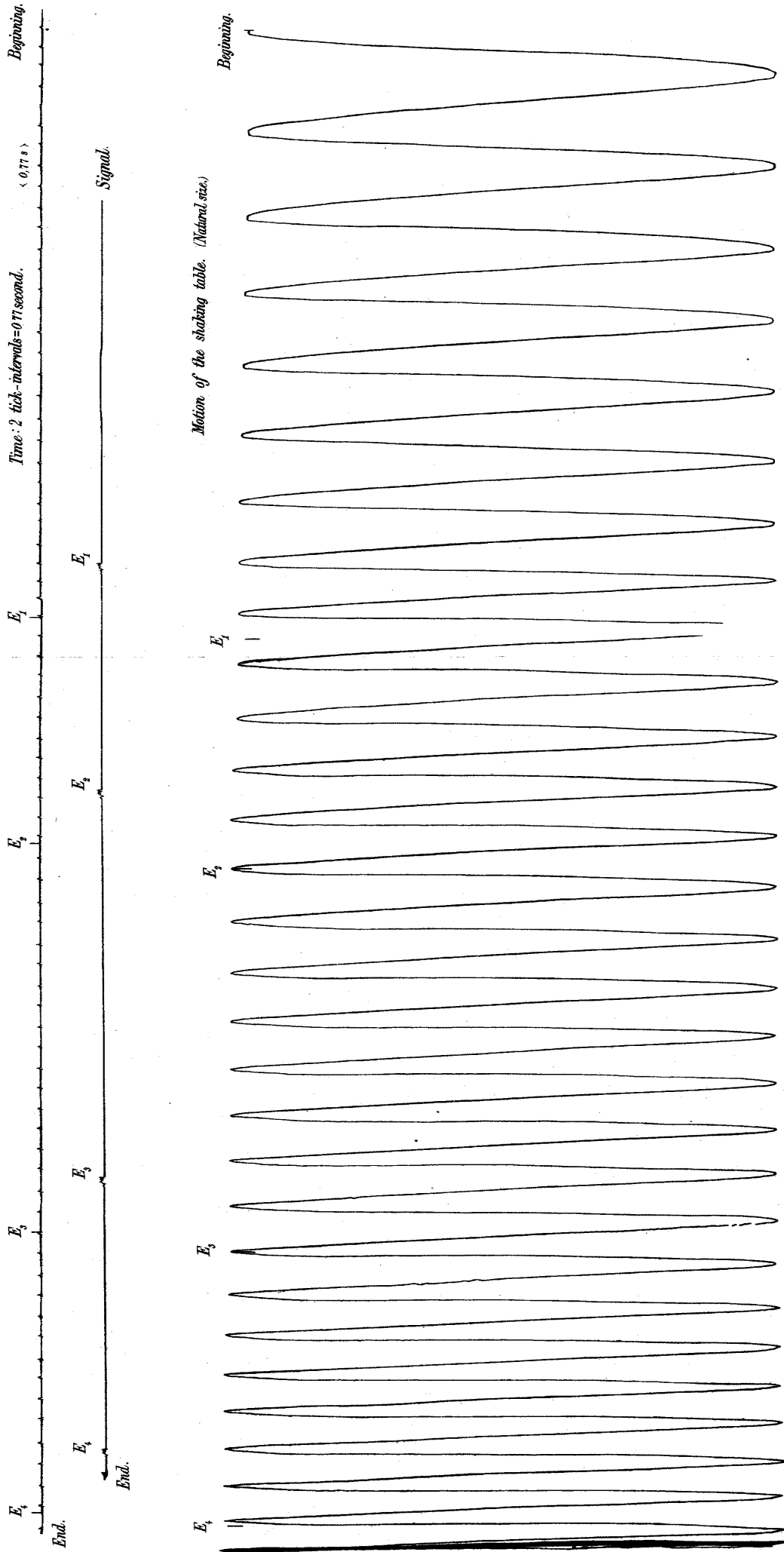

The four columns were overturned respectively at E_1, E_2, E_3 and E_4 .