

On Multi-dominance in Restrictive Relative Structures*

Shunichiro Inada
Meiji Pharmaceutical University

inada@my-pharm.ac.jp

This paper argues, based on the DP-internal multi-dominance analysis of restrictive relative structures presented in Inada (2016), that the restrictive relatives in English involve sharing of NumP, a nominal functional layer in between DP and NP. The proposed analysis accounts for the adjunction property of restrictive relative clauses and the reconstruction effects of the Head Nouns. The multi-dominance structure with a shared element is shown to be obtained by simultaneous applications of External Merge, which are operative for the computation of Narrow Syntax, which must be equipped with the formation of the two intersecting sets as a complex set.

Keywords: restrictive relative clauses, reconstruction effects, adjunction, multi-dominance

1. Introduction

This paper investigates the structure and interpretation of restrictive relatives in English by examining how the adjunct property of restrictive relative clauses and the reconstruction effects of the Head Nouns are accounted for based on the multi-dominance analysis presented in Inada (2016).

In restrictive relative structures, a relative clause includes a gap *e* corresponding to the Head Noun. As seen in (1), we observe a certain linking relation between the Head Noun and the position of the gap inside the relative clause (Schachter (1973), Browning (1987), Kayne (1994), Bianchi (1999), Aoun and Li (2003), a.o.).

- (1) a. The boy [who Mary saw *e*] is my younger brother.
b. The headway [that Mel made *e*] is impressive. (Aoun and Li (2003: 110))
c. The picture of himself_i [that John_i painted *e* in art class] is impressive. (Aoun and Li (2003: 111))

In (1a) the Head Noun *boy* is construed as an argument of the predicate in the relative clause *who Mary saw*. In (1b) the Head Noun *headway* is construed as a part of the idiomatic phrase *make headway* in the relative clause. In (1c), the reflexive pronoun *himself* contained in the Head Noun is coreferential with the subject of the relative clause *John*. These phenomena are called reconstruction effects.

The reconstruction effects are also observed when fronted *wh*-phrases are interpreted. Look at the examples in (2).¹

- (2) a. What headway [did John make *e* today]?
b. Which picture of himself_i [did John_i show you *e*] ? (Henderson (2007: 204))

The fronted *headway* in (2a) is interpreted as a part of the idiom, and the reflexive pronoun *himself* in (2b) is

* This paper is based on the presentation given at GLiM, 14 February 2016, Tsuda College. I would like to thank the audience for their helpful comments. I owe thanks as well to Noriko Imanishi, Akira Watanabe, Carey Benom, Sakumi Inokuma, and Mioko Miyama for their valuable comments on the earlier draft. Needless to say, all remaining inadequacies are mine. This research is supported by JSPS Grants-in-Aid for Scientific Research (No. 26370505).

¹ Notice that all of the bracketed constituents in (1)-(2) can be considered the same in size, i.e., C' in the traditional X'-theoretic notation, which consists of C and TP.

interpreted as coreferential with the subject *John*.

When a fronted *wh*-phrase is accompanied by a relative clause, one might suppose that the relative clause is interpreted at the gap position of the *wh*-phrase. Consider the contrast illustrated in (3).

- (3) a. Which picture [that John_i likes *e*] [did he_i buy *e*]?
 b. * He_i bought a picture [that John_i likes *e*] (Putnum (2007: 131))

In (3a), the proper name *John* in the relative clause is coreferential with the subject *he* when the relative clause accompanies the fronted *wh*-phrase *which picture*. As seen in (3b), the proper name in the relative clause cannot be coreferential with the subject unless the Head Noun is fronted. If the fronted Head Noun underwent reconstruction with the accompanying relative clause which contains the proper name *John*, it would be responsible for the ill-formedness—a violation of Binding Condition C. Thus, the fronted *wh*-Head Nouns are not interpreted in combination with the accompanying relative clauses at the gap position in the matrix clause.

Even though the accompanying relative clauses are not interpreted at the matrix gap position, the fronted *wh*-Head Nouns are interpreted at the gap position inside the relative clauses as seen in (4).

- (4) a. What headway [that John_i made *e*] did he_i later regret *e*?
 b. Which picture of himself_i [that John_i gave *e* to Mary_k] did she_k take *e* home? (Henderson (2007: 214))

The reconstruction paradox we have seen above indicates that in restrictive relative structures, relative clauses are tightly combined with the Head Noun AND loosely related to them, free from some structural relations with the other matrix elements. This paper examines how the reconstruction paradox is accounted for by a novel analysis of restrictive relative structures presented in Inada (2016). Inada (2016) claims that the underlying representation for restrictive relative structures is not a subordinate structure but a conjunction-like structure, as suggested originally in Thompson (1971). Thompson's idea is that the sentence in (5a) is equivalent to two conjoined predications on the same argument as illustrated in (5b).

- (5) a. I met the girl who speaks Basque. (Thompson (1971: 81))
 b. (I met girl)(girl speaks Basque)

In this structure, the Head Noun is shared between the matrix clause and relative clause in the multi-dominance structure as illustrated below.

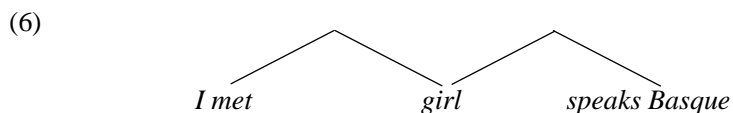

With this multi-dominance analysis of restrictive relative structures, the reconstruction paradox can be illustrated as follows.

- (7) a. [Which [picture of himself_k]] [that_C [TP John_k likes *e*]] [did_C [TP he_k buy *e*]]?
 b. [which [picture of himself_k]] did he_k buy *e* that John_k likes

In the structure (7b) the fronted *wh*-Head Noun is interpreted at the gap position in the matrix clause and that in the relative clause. At the same time, the matrix clause and the relative clause are coordinated, which leads to the

adjunctive status of the restrictive relative clauses, i.e., they are not interpreted with the fronted *wh*-Head Noun at the gap position in the matrix.

In the following, Section 2 introduces theoretical framework. Section 3 considers a multi-dominance analysis for restrictive relatives and shows that the multi-dominance structure is formed legitimately in the computation in Narrow Syntax. Section 4 examines how the multi-dominance analysis can account for the reconstruction paradox in restrictive relative structures. Section 5 concludes the paper.

2. Forming Complex Syntactic Objects

2.1. Merge

This paper assumes the framework of the Principles-and-Parameters Approach with particular attention to its current developments within the Minimalist Program for the linguistic theory (Chomsky (2000, 2001, 2004, and 2008)). In this framework, a syntactic structure is a syntactic object formed by applying Merge in the computation in Narrow Syntax. The operation Merge is distinguished into two types: Set-Merge, which introduces arguments, and Pair-Merge, which introduces adjuncts. The complementation takes the form of Set-Merge, which is characterized as a simple set-formation $\{\alpha, \beta\}$, whereas adjunction takes the form of Pair-Merge, which creates an ordered pair $\langle \alpha, \beta \rangle$. The formed sets by applying Merge can be diagrammed as a tree. A syntactic object formed by Set Merge (α, β) is illustrated in (8a), and one by Pair Merge (α, β) is in (8b).^{2,3}

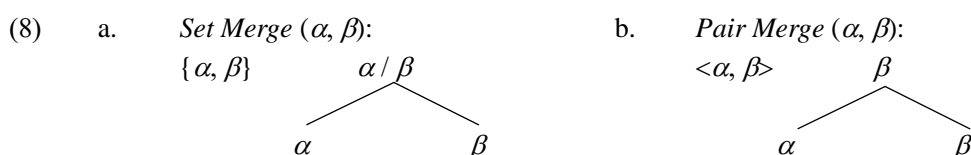

In addition, the formed ordered pair $\langle \alpha, \beta \rangle$ requires a special operation for spelling-out, SIMPL, which converts the pair into $\{\alpha, \beta\}$ (Chomsky (2000: 133, 2004: 117-118)). Chomsky (2004) assumes that the adjunct is attached to the matrix tree later in the course of the derivation and the adjunction of α to β does not change the properties of β because it is built on a “separate plane (p 118)” of a syntactic workspace devoted for building syntactic structure.⁴ The adjunct α comes down to the primary plane to become a simple structure at the stage where the pair-merged object $\langle \alpha, \beta \rangle$ is spelled out. That is, the operation SIMPL converts $\langle \alpha, \beta \rangle$ to $\{\alpha, \beta\}$.

Merge itself is applied without any constraints. When α and β are merged, either β is not part of α (External Merge) or β is part of α (Internal Merge). Moreover, what can undergo the operation Merge is not only the items from lexicon, but any syntactic object that has been already built for ongoing syntactic computation.

2.2. Internal Merge, Copy Theory of Movement, and Reconstruction Effects

Internally-merged elements are left unaffected because Merge cannot add new features to syntactic objects: a “no-tampering condition (Chomsky (2008: 138)).” Chomsky (2008: 138, 140) claims that Merge is invariably “to the edge” and we also try to establish the “inclusiveness principle,” dispensing with bar levels, traces, indices, and similar descriptive technology introduced in the course of derivation of an expression, and I[nternal] M[erge]

² Merge joins the units to the highest node of the syntactic object which it is forming, which is referred to as root (Extension Condition).

³ Notice that the labels of the nodes are sets, not categories. In this paper the label of the output is given either α or β only for the expository purposes.

⁴ Chomsky (2004) claims that SIMPL applies at the stage of the derivation which Spell-Out applies—part of the operation TRANSFER, which transfers the derivation of Narrow Syntax to the two interfaces. Chomsky utilizes the notation of the ordered pair to capture an intrinsic asymmetry between complementation and adjunction. Adjunction is an optional process that merges α to β .

According to Chomsky (2004: 118-119), for β to lose some property when α adjoins to it would be an “imperfection.” The relation c-command(X, β) is therefore not lost when α is adjoined to β : accordingly, X still c-commands β in $\langle \alpha, \beta \rangle$, as before adjunction. But extension of c-command to the adjoined element α would be a new operation, to be avoided unless empirically motivated.

creates copies. When the indices on tokens within the internally-merged β are identical to those of “unremerged” β , it means that copies of any token created by Internal Merge are indistinct from one another, i.e., the Copy Theory of movement.⁵

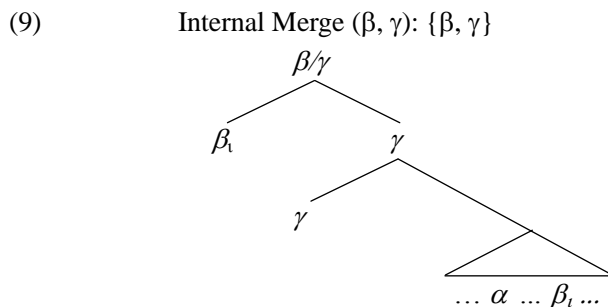

It is worth pointing out here that what is shown in the tree diagram (9) is a structure of multi-dominance of β built by applying Internal Merge. In this respect, the structural manifestation in (9) and the one in (9)' are considered notational variants (cf. McCawley (1981), Phillips (1996), Wilder (1999), Cann (1999), Starke (2001), Gärtner (2002), Abels (2003), Citko (2005, 2011), de Vos and Vicente (2005), and de Vries (2009)).⁶

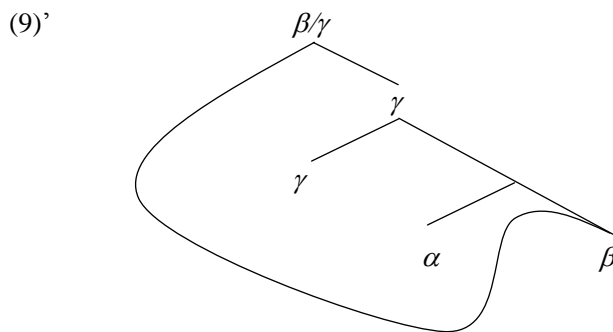

We can say that Internal Merge creates a multi-dominance structure in which a moved element is simultaneously located at the two structural positions. The set formed by an application of Internal Merge is given in (10).

(10) $\{\beta, \{\gamma, \{\alpha, \beta\}\}\}$

Internal Merge of β is triggered when γ agrees with β via the operation Agree, and the feature of γ requires that Internal Merge of β targets the root node dominating γ .

- (11) *Agree* (Chomsky (2000, 2001))
 Probe γ can establish Agree with Goal β iff (a) and (b) hold.
- a. γ c-commands β .
 - b. There is no Goal α such that γ c-commands α and α c-commands β .

A Probe is a head with a set of features that must be matched with a Goal of agreement. To be matched, Goal must be in the domain of Probe and satisfy locality conditions. Chomsky (2000:122) assumes that domain D is

⁵ In this paper indices are only used for the expository purposes.

⁶ As roughly illustrated here, it is possible to recast a copy-theoretic implementation in (9) into a notation of multi-dominance analysis in (9)'. It is often argued, however, that these two ways to encode movement are not totally equivalent: they are based on different assumptions about mapping to LF/PF. Each one must resort to different assumptions to yield the appropriate mapping of output of Narrow Syntax to LF/PF. See Vicente (2009) for the discussion this respect.

the c-command domain of Probe, and matching feature G is closest to P if there is no G' in D matching Probe.

When a lexical item LI merges with a syntactic object SO, it must have some property to permit the application of the operation Merge. The property is called the *edge-feature* (EF) of the LI in Chomsky (2008), which triggers Internal Merge. For example, restrictive relative clauses are derived via A'-movement of the “relative operator” to the position Spec,CP. Then, C has [EF] in addition to REL-feature [REL]. Such a C probes into the sister domain TP and makes its specifier a Goal with [REL] in the domain. In other words, the phrase undergoes A'-movement to check the REL-feature of C, as illustrated in (12).^{7,8}

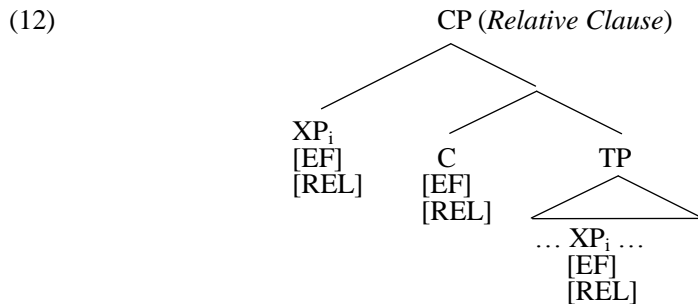

Notice that under the Copy Theory of movement, the “relative operator” with [REL] leaves its full copy at the base-position within the relative clause since such an “operator” is a syntactic object in Narrow Syntax, whose copy at a certain scope-taking position is later interpreted as a semantic operator in the semantic component. At the base-position, a copy of such a potential “operator” is interpreted as a variable bound by the operator.

Based on the Copy Theory of movement stated above, the reconstruction effects follow straightforwardly.

- (13) * [Which picture of Bill_i]_k did he_i buy e_k?

A copy created by Internal Merge is made of the particular lexical item(s) and merged into the derivation. The *wh*-phrase in (13) leaves its copy at the position of the gap, as is illustrated in (14) with the copies embraced with angled brackets.

- (14) * <which picture [of Bill_i]>_k did he_i buy <which picture [of Bill_i]>_k
cf. * He_i bought a picture of Bill_i.

The reconstruction effects follow when one of the copies located lower than the surface position is interpreted at the semantic interface.

3. Multi-dominance in Restrictive Relative Structures

3.1. Forming Multi-dominance Structures and Interpretation of Restrictive Relative Structures

Under the Copy Theory of movement within the framework presented in Section 2, the reconstruction paradox observed in restrictive relative structures can be illustrated as follows.

⁷ Chomsky (2008: 144) assumes only phase head triggers movement.

⁸ Cable’s (2010) Q-based theory assumes that fronting of the *wh*-element in languages like English is only a secondary effect of Q-movement, and so is the one in relativization. Cable argues that both of the two constructions exhibit the following three properties, “(i) inability to strand adpositions, (ii) inability to extract possessor and determiners, and (iii) possibility of pied-piping structures (Cable (2008: 202)).” In Cable’s analysis, a nominal functional head named Q has REL-feature in the restrictive relative structures and takes a relative pronoun as its complement. This QP undergoes A'-movement to check the REL-feature of C.

Although this Q-based analysis is a general approach to A'-movement, this paper does not adopt the analysis. Instead, this paper will argue for a layered DP-structure, which divides it into at least two parts: a functional layer which forces A'-movement of the entire DP and a lexical layer which induces intersective interpretation between the Head Noun and the relative clause.

(7) Which picture of himself that John likes did he buy?

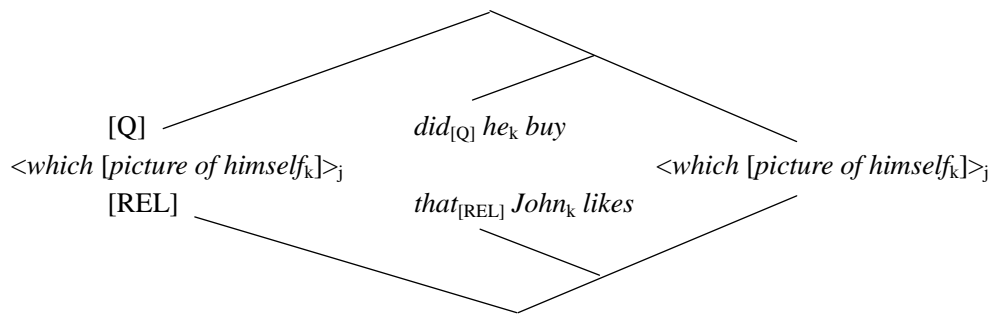

The Head Noun *picture of himself* is interpreted at the base position of the *wh*-phrase and at the position of the gap inside the modifying relative clause. On the other hand, the relative clause is not interpreted at the base position of the *wh*-Head Noun. The question is whether such a complex syntactic object is allowed to be formed, and if it is allowed, how it is formed.

Thompson (1971) suggests that the underlying representation appropriate for restrictive relative structures is a conjunction. In this light, what underlies the sentence in (15a) is a structure like (15b).

(15) a. I met the girl who speaks Basque.

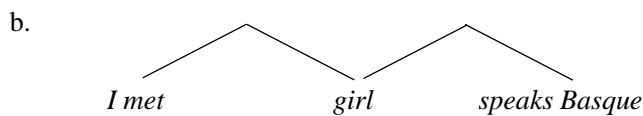

In this structure the Head Noun is shared between the matrix and relative clause. In other words, the Head Noun is multiply dominated in (15b).

3.1.1. Forming Multi-dominance Structures

Citko (2005, 2011) proposes that assuming that the operation Merge in general can freely apply to any syntactic object, whether it is a root object or not, the derivation is possible in which an XP is first externally-merged with an element Y “and then” merged with another element W.

(16) a.

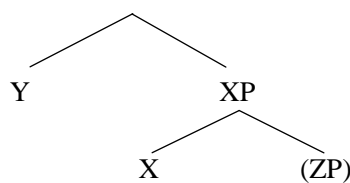

b.

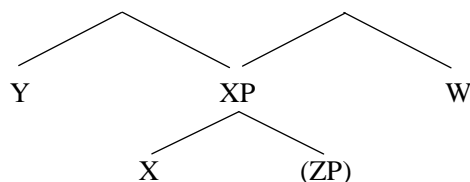

As a result, there arises an XP which is multiply dominated by the two heads Y and W. The application of Merge in (16) is called “Parallel Merge.” In the multi-dominance structure in (16), XP constitutes an intersective set of the two syntactic objects YP and WP.

Notice that under the minimalist framework introduced in Section 2, the derivation of Parallel Merge presented in (16a-b) cannot be counted as a legitimate operation as Merge. Without probing, only root nodes undergo Merge, and probing requires a Goal β of a Probe γ to be contained in the sister of γ . For the complex

syntactic object represented in (16b) to be formed, therefore, we must assume that External Merge is allowed to independently target multiple elements (Y and W) at a root object (XP). This simultaneous targeting yields the multi-dominance structure in (16b) from Y, W, and XP all at once, which is not derived from (16a) by merging the non-root object without probing.⁹

Another possible argument which might be paused against the legitimacy of the multi-dominance structure in (16b) is that it cannot be a representation of the object(s) formed by a legitimate set-formation operation. However, we can say that the tree diagram in (16b) is a representation of two sets which have members in common. This is shown in (17).

$$(17) \quad \begin{array}{l} \{Y, \{X, ZP\}\} \\ \{W, \{X, ZP\}\} \end{array}$$

Each of these two sets is a normal set which can be defined in terms of other sets by using set operations. Given two sets *A* and *B*, we may define the set that consists of all objects that are members of both *A* and *B*. This set is called an intersection of *A* and *B* and denoted by $A \cap B$. The identity of the shared member, i.e., the set $\{X, ZP\}$ of $\{Y, \{X, ZP\}\}$ and that of $\{W, \{X, ZP\}\}$, is guaranteed between separate sets. If so, the configuration of multi-dominance can be illustrated as follows.

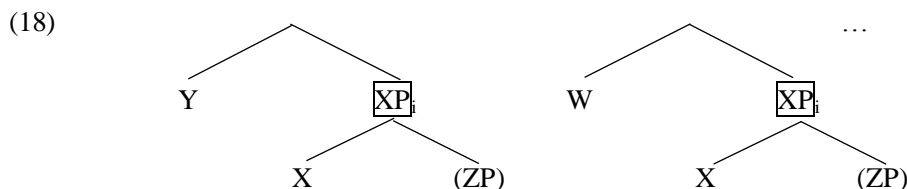

In (18), the two copies of XP enclosed are instances of a shared/multiply-dominated element in (16b).

Let us further elaborate the notion that the shared element in (16b) is multiple copies in (18). When the sets *A* and *B* include only X and ZP, *A* (i.e., $\{X, ZP\}$) is identical with *B* (i.e., $\{X, ZP\}$), which is denoted symbolically as $XP = XP$ —the copies of XP. This notion of copying leads us to hypothesize that a set can always be “multi-dimensional” if necessary. To illustrate, a shared member XP of the intersecting sets in (19a) is the multiply “superpositioned” copies of XP in (19b).

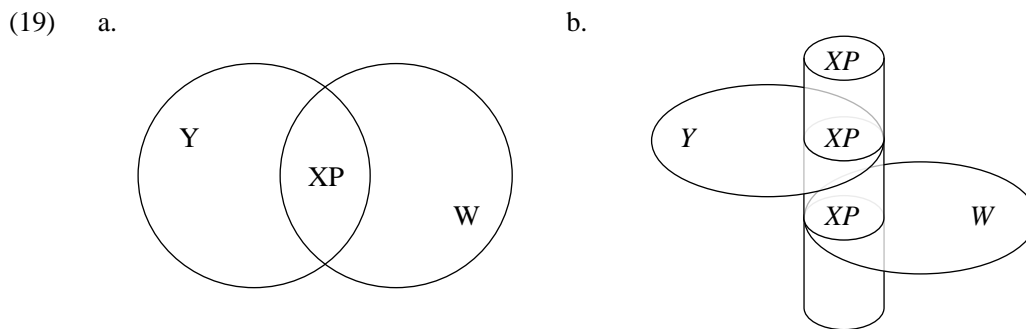

In (19b), the identity of the two objects, XP of $\{Y, \{X, ZP\}\}$ and that of $\{W, \{X, ZP\}\}$ are guaranteed between separate subsets in different planes, and each of the superpositioned sets (XPs) can always be ready to add independent members.

⁹ On a possible application of Merge, de Vries (2009) also refers to the same configuration obtained by the application of free Merge as “External Rmerge.” According to de Vries (2009), External Rmerge is not an instance of Internal Merge, but an External Merge between a root and an already-embedded syntactic object. However, it still seems to require targeting at a non-root object in the subtree, which cannot be permitted in the computation in Narrow Syntax, although the output of External Rmerge yields the multi-dominance configuration, (cf. McCawley (1982), Phillips (1996), Wilder (1999), de Vos and Vicente (2005), Larson (2009), and de Vries (2009)).

3.1.2. Interpretation of Restrictive Relative Structures

In restrictive relative structures, the combination of a Head Noun with a relative clause denotes the intersection. Restrictive relative clauses themselves are construed as a one-place predicate, i.e., an expression of type $\langle e, t \rangle$, formed by λ -abstraction over a variable associated with a λ -operator, which is also known as Functional Abstraction or Predicate Abstraction in the literature.¹⁰ λ -abstraction is simply an interpretive reflex of a configuration involving an operator-variable chain. In (20) the relative clause *who Mary saw* is construed as a one-place predicate with the relative pronoun *who*, whose copy in the scope-taking position is interpreted as a relative operator in the semantic component.¹¹

$$(20) \quad [who_1 [Mary\ saw\ who_1]] \rightarrow \lambda x_1\ see'(Mary', x_1)$$

The relative clause in (20) can then be used in the semantic representation to modify the Head Noun *boy*, a common noun phrase, which is also an expression of type $\langle e, t \rangle$. Since the type of the relative clause and the Head Noun are both predicate (type $\langle e, t \rangle$), Predicate Modification or a set intersection (or Generalized Conjunction (Partee and Rooth (1983)) gives the representation $\lambda y [HeadNoun'(y) \ \& \ RelativeClause'(y)]$. The example is demonstrated in (21)¹²

$$(21) \quad [boy [who_1 [Mary\ saw\ e_1]]] \rightarrow \begin{aligned} & boy' \ \& \ \lambda x_1\ see'(Mary', x_1) \\ & = \lambda y [boy'(y) \ \& \ \lambda x_1\ see'(Mary', x_1) (y)] \\ & = \lambda y [boy'(y) \ \& \ see'(Mary', y)] \end{aligned}$$

As shown above, the semantics for restrictive relative structures requires the attributive modification by the set intersection.¹³

Following the idea of Thompson (1971), the derivation of the restrictive relative clauses involves forming intersecting sets. Such an output of Narrow Syntax can be considered as the most transparent one mapped automatically onto the representation of intersection. The discussion above leads us to claim that External Merge can target at multiple superpositioned sets which can be shared among various (or possibly infinite) subatomic events in the different planes simultaneously, and yields multiple intersecting sets. In what follows, this way of application of External Merge is referred to as share-merging.

¹⁰ The λ -operator is the function from the objects that can be values of the variable bound by the operator to the propositions expressed by the sentences which are obtained when the reference of the variable is fixed.

¹¹ Trace Conversion (Fox (2003), Sauerland (2004), Johnson (2007)) turns the lower copy of a moved constituent into a definite description and inserts a variable that can be bound by the higher copy. The formulation in Johnson (2007) is as the following.

- (i) In the movement structure $DP_n [\phi \dots DP_n \dots]$, interpret ϕ as a function that maps x to the meaning of $\phi [x/n]$.
- (ii) The meaning of $\phi [x/n]$ is the result of replacing the head of every constituent with index n in ϕ with the head the_x , where $\llbracket the \rrbracket = \lambda P. \llbracket the \rrbracket [P \cap \lambda y. y=x]$.

¹² See Quine (1960), Partee (1975: 229), and Larson and Segal (1995: 256) for the discussion.

¹³ Note that a definite description can be an external expression which picks out a certain individual object by describing it as “the object which has such and such property.” There are no definite descriptions in the language of ordinary predicate logic, but it can be extended by introducing an ι -operator. Using the ι -operator, we can write e.g. “the x which is such that it has the property F .”

- (i) $\iota x F(x)$.

Then, the definite article *the* yields the singular term.

Thompson (1971) claims that Restrictive relative clauses with indefinite nouns do not “restrict” the Head Nouns in the way relative clauses with definite nouns do. Consider the examples below.

- (ii) a. I met a boy who Mary saw.
- b. Mary saw a boy I met.
- c. I met a boy and Mary saw him.
- (iii) a. I met the boy who Mary saw.
- b. Mary saw the boy who I met.

Following her hypothesis, the apparent restricting nature of the restrictive relative clauses with definite Head Nouns is a function of the presuppositions.

3.2. Linearization of Multi-dominance Structures and DP-internal Syntax

Notice that another potential problem of the sharing structure obtained by the simultaneous applications of External Merge contributes to a certain problem for the SM interface. As it stands, the multi-dominance structure can be “unlinearizable.” For instance, Kayne (1994) proposes Linear Correspondence Axiom (LCA), which requires that linear order is determined by hierarchical structure. Under LCA, the multi-dominance configuration in (16b) (or (18)) is problematic. Its symmetrical structure cannot assign linear order between the two sequences Y-XP and W-XP in (16b) (or (18)) since neither Y nor W c-commands the other. It would indicate that a configuration of multi-dominance in restrictive relative structures which share-merging yields is a possibly “unlinearizable” structure, and violates the interface condition at SM interface.

The multi-dominance structure can be, however, linearized if the shared element is somehow externalized at the position higher than the place where the subtrees are merged (cf. Moro (2000)). This is demonstrated in (22).

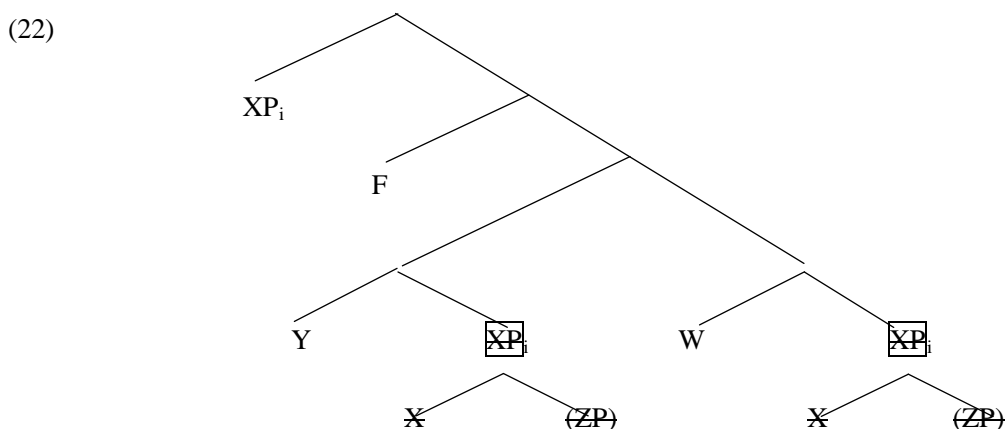

The linearizable structure can be obtained if the two phrases which share an element are merged under a functional head that probes into both phrases to induce movement of the shared element, forcing the lower copies to be unpronounced.

In restrictive relative structures, what is shared, and thus what should raise for dissolving the unlinearizable structure, is the Head Noun. Then, what does the “movement of the Head Noun” mean in the restrictive relative structures like (23)? Moreover, where is the “higher position” for the Head Noun to be externalized in (23)?

(23) I met the girl who speaks Basque.

In (23), the Head Noun seems to be in-situ at first, which means that its unlinearizable structure is not dissolved.

In this respect, proper understanding of the DP-internal syntax is important in connection with the syntax of restrictive relative structures. Recent work on the DP-internal structure (Bernstein (1991, 1993), Picallo (1991), Ritter (1991), Zamparelli (1995)) has shown that DPs are more highly structured with the multiple functional heads which reflects the noun phrase semantics. Furthermore, Koopman (2000) argues that the internal structure of DP has a certain functional layer, which is called Num(ber)P, and the linear order of the constituents in the DP is derived by the movement of Num(ber)P. Watanabe (2006, 2008) also argues that the movement of NumP takes place, but it is argued to move because it agrees with another functional projection CaseP hypothesized in between the topmost DP layer and the NumP layer.¹⁴

¹⁴ This paper adopts that NumP agrees with Case with the feature [FF], which forces the NumP to raise to the Spec,CaseP, so that as argued in Watanabe (2008) the fixed values of the feature make the entire DP (non-)specific.

(24)

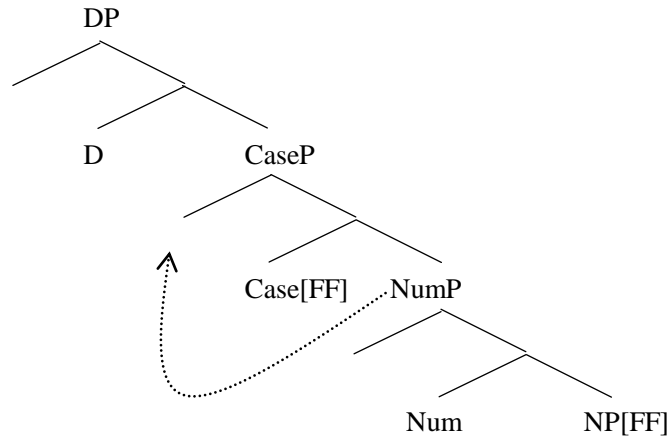

From this perspective, Inada (2008) argues that this NumP layer constitutes Head Nouns of restrictive relative structures. Inada also argues, following Aoun and Li's (2003) distinction between weak and strong quantifiers, that only weak pronominal quantifiers, which are included in NumP layer, can take lower scope than the scoping elements in the relative clause by interpretation of the base copy (Aoun and Li (2003)).¹⁵

- (25) a. John will interview [_{DP} the [_{NumP} two patients] that every doctor would examine e].
 (two > every, every > two)
 b. I read [_{DP} every₁ [_{NumP} paper] that every₂ professor in my department recommended e].
 (every₁ > every₂, *every₂ > every₁)

The independent motivation for the DP-internal NumP movement irrespective of restrictive relative structures explains how the complex syntactic object sharing NumP yields an appropriate output. This is illustrated in (26).

(26)

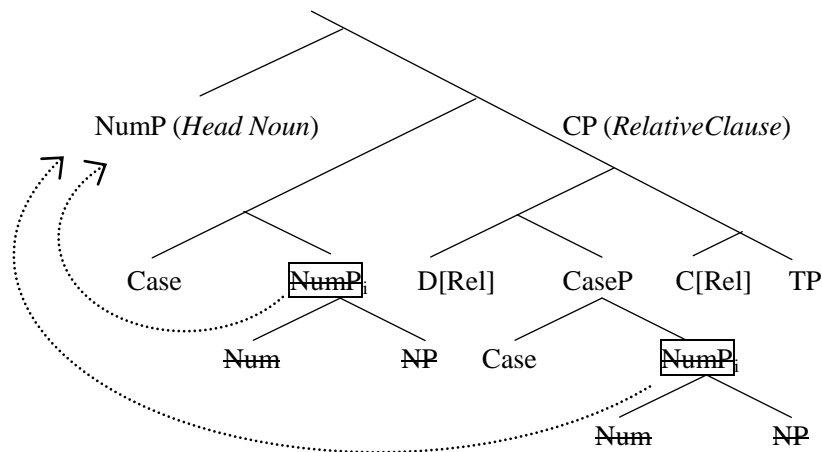

In (26) the output of the NumP movement is linearizable with the elimination of the copies of the shared element NumP at the bottom of the restrictive relative structure. We can conclude that the legitimate configuration (22) has already been presented for the independent reasons, in which the apparently problematic nature of unlinearizable but semantically transparent configuration built by share-merging is resolved autonomously.

Note that the structure involving NumP movement is also presented in Cinque's (2015) analysis for restrictive relative structures although the movement is given for the proper arrangement of the word order. Under the hybrid analysis for restrictive relative structures, Cinque argues that only internal Head Noun raises to

¹⁵ Inada (2008) claims that the projection which constitutes the raising Head Nouns is FP, a nominal functional projection located in between DP and NP for the number agreement inside the DP.

Spec,CP in Head-Raising relatives while both the internal and external Head Noun raise in Matching relatives. The two kinds of raising of the Head Nouns in Cinque (2015) are illustrated in (27).

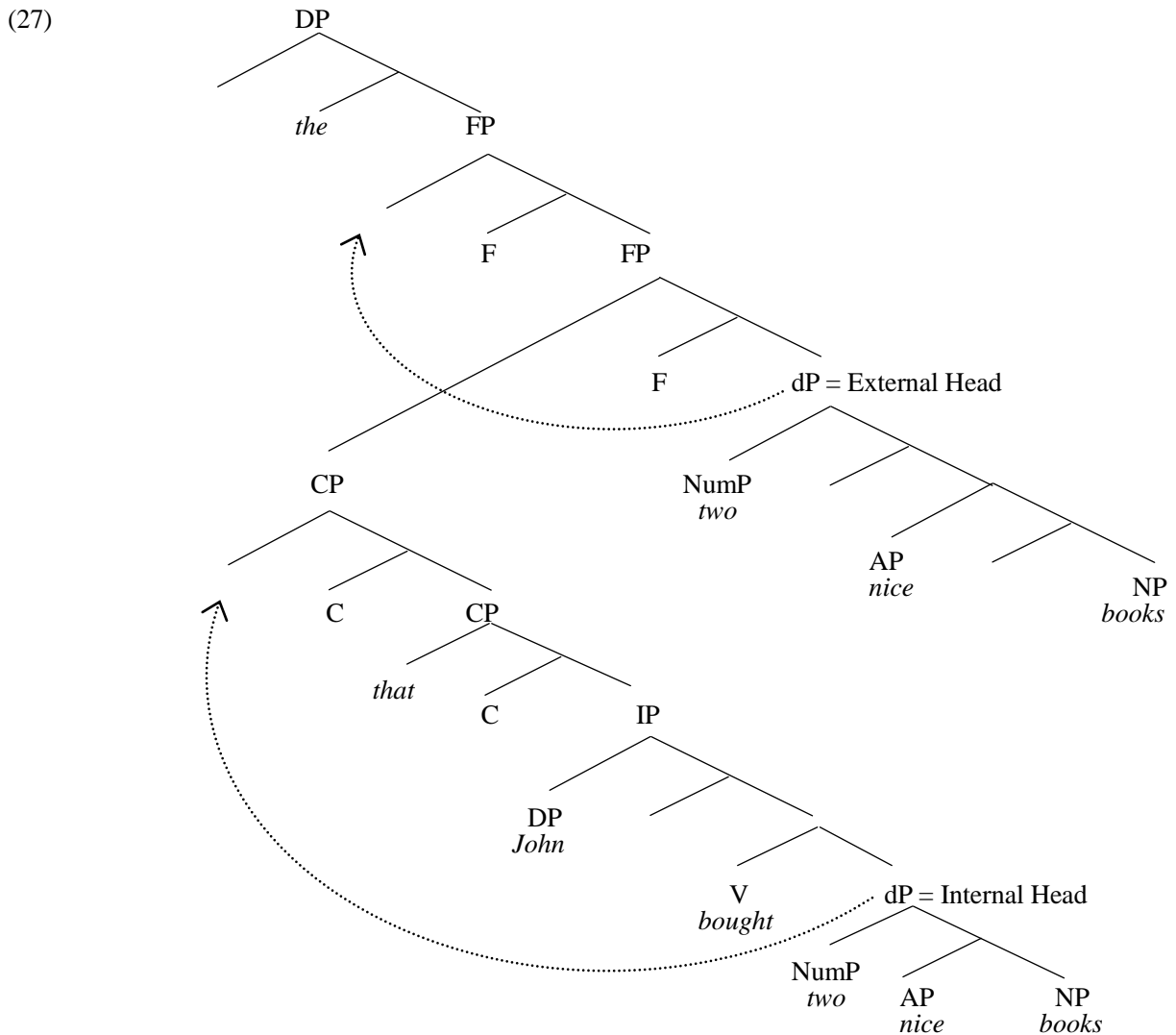

The moved constituent which is dubbed dP is an intermediate functional layer within the DP structure. In our analysis, this dP is considered as NumP because it is the functional layer for the number information. In this respect, both of the Head-Raising and Matching relatives in his analysis seem to have a similar configuration to our restrictive relative structures.¹⁶

¹⁶ The distinction between Head-Raising and Matching in Cinque (2015) depends on whether the external Head Noun moves or not. Cinque claims that the movement of the two dPs causes the internal Head Noun either to be “deleted completely,” or to be “reduced.” The deletion is illustrated as in (ia) and the reduction is illustrated as in (ib).

- (i) a. the books ~~which books~~ that I bought
 b. the books which ~~books that~~ I bought (Cinque (2015: 6))

Cinque (2015) assumes the two derivations because the analysis accounts for the ambiguity exemplified below.

- (ii) a. John guessed the price [that Mary guessed].
 A. John and Mary happened to guess the same price, but not necessarily anything about one another.
 John and Mary need not even know of the other’s existence.
 B. John guessed something about Mary; that is, John guessed the answer to the question “What price did Mary guess?”
 b. John guessed the price yesterday [that Mary guessed].
 A / #B (Cinque (2015: 9-10))

Cinque (2015) argues, following Harris (2008) that the reading A is derived from a structure of Matching relatives and the reading B is derived from a structure of Head-Raising relatives.

Then, the reduction of *that* in the derivation of Matching relatives presented in (ib) would be optional since it is

However, the analysis would say nothing about the reconstruction paradox in restrictive relative structures, which is repeated below.

(28) Which picture of Bill_i [that John_i like *e*] did he_{i/*j} buy *e* ?

In (28) the fronted *wh*-Head Noun is interpreted at the two gap positions, that is, the gap in the relative clause and the one in the matrix clause, whereas the relative clause is interpreted only at the surface position. In Cinque's (2015) analysis, the relative clause CP is a specifier of the lower FP as shown in (27), which cannot be absent in the interpretation of the FP at the matrix gap.

3.3. Adjunction of Relative Clauses in Multi-dominance Analysis

Let us now consider the adjunction of the relative clause to the Head Noun. As repeated in (29), the proper name *John* inside the relative clause circumvents violation of Condition C.

(29) [Which picture of Bill [that John_i likes]] did he_i buy?

Notice, however, that the proper name does violate Condition C when the relative clause occurs inside the domain of the binder, as shown in (30).

(30) * He_i bought [a picture of Bill [that John_i likes]]. (Putnum (2007: 131))

The absence of the reconstruction effect in (29) leads us to argue that the relative clause is not construed in the gap position.

Recall that SIMPL applies at the stage of the derivation which Spell-Out applies—part of the operation TRANSFER, which transfers the derivation of Narrow Syntax to the two interfaces. In effect, the principle (31) holds.

(31) In $\langle \alpha, \beta \rangle$, α is spelled out where β is (Chomsky (2004: 20))

Given (31), the adjunction structure accounts for the reconstruction paradox shown in (29)- (30). The proper name *John* inside the relative clause in (29) is interpreted outside the scope of the matrix subject because the relative clause is pair-merged with the Head Noun and it comes down to the primary plane at the stage where the Head Noun is spelled-out. The proper name *John* in (30) is spelled-out in the scope of the binder, which induces the violation.

Chomsky (2004) presents the theory concerning the adjunction structure extensively, claiming that “[DET <ADJ, NP>] receives theta-role in the normal way, with composition of the predicates NP, ADJ, [and] [w]e take [DET < α , β >] to be ‘in a configuration’ at SEM, but that seems unproblematic” and “‘in a configuration’ is not one of the relations defined for simple structures, and the assumption here is as natural as any (p.118).” Given that Merge applies freely, the legitimate adjunction site would be determined uniquely in the passive manner with the effect of the interface conditions, and there, the “type-preserving” property of Pair-Merge must follow automatically.¹⁷

also considered a Matching relative clause. In addition, the relative pronoun *which* might also be a target of the reduction.

¹⁷ The question of where is the unique adjunction site of the clausal adjunct which involves a gap inside has been a long-standing issue in the research on parasitic gap constructions. A defining property of parasitic gap constructions is that the adjunct clause involves a gap which is licensed in certain movement configuration. A variety of movements are able to license the gap inside the adjunct clause, including *wh*-movement, topicalization, relativization, and heavy-NP shift.

- (i) a. Which article_i did you file $_i$ [without reading $_i$]?
- b. John, I talked to $_i$ [in order to impress $_i$].

Given these assumptions, a unique adjunction site of restrictive relative clauses is determined automatically via the NumP movement, which is involved in the DP-internal syntax irrespective of adjunction of the relative clauses. Look at the derivation in (32).

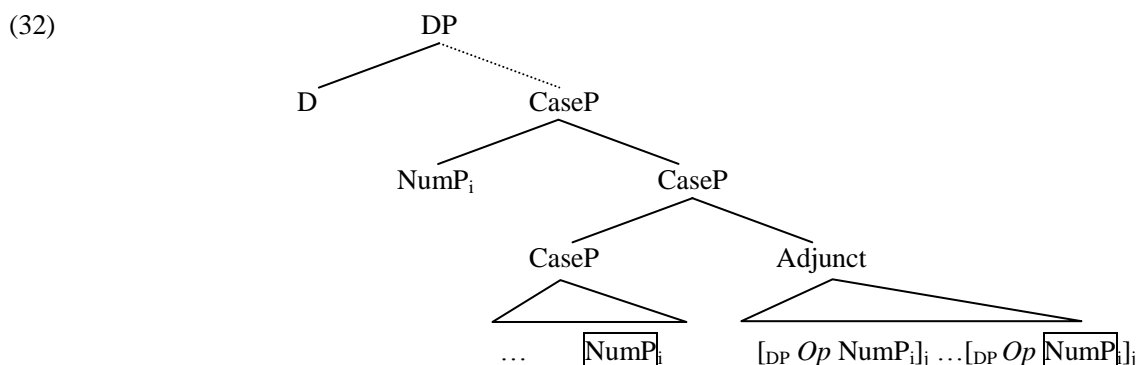

The NumP movement within the matrix DP licenses the NumP-chain in the relative clause, though the chain is formed along with the A'-movement of the DP-structure of the relative operator DP. By raising of NumP to Spec,CaseP in the matrix DP, the semantic composition is made possible for the relative clauses to modify CaseP. The lower segment of CaseP turns into a derived predicate because it is interpreted as a λ -abstract that binds variable in the base position of the raised NumP. Then, the two predicates, the lower CaseP and the relative clause, compose by Predicate Modification as we have seen in Section 3.1.2, and the result applies to the raised NumP by Function Application. The semantic interpretation of restrictive relative structures derived via share-merging is straightforward using independently needed interpretive mechanisms. If this is a right track, the structure presented above for the restrictive relatives is not only the one which satisfies the structure-preserving nature of the adjunction but also the one which automatically offers the adjunction site lower than the surface Head Noun NumP.

3.4. A Unified Account: NumP Sharing Structure for Restrictive Relatives

Let us consider a derivation of the example presented in (33) under the DP-internal multi-dominance analysis of restrictive relative structures. First, the set in (33i), which consists of the noun *boy* and its number information, undergoes share-merging and forms the two intersecting sets which share $\{two, boys\}$ in common as illustrated in (33ii).

- (33) The two boys who Mary saw yesterday are my younger brothers.
- i. $\{two, boys\}$
 - ii. $\{Case, \{two, boys\}\} / \{Case \{two, boys\}\}$

Next, one of the intersecting sets undergoes External Merge with the relative pronoun *who*, which bears the feature [REL] as illustrated in (33iii), and then the set $\{who, \{Case, \{two, boys\}\}\}$ is formed and undergoes Internal Merge with the superset $\{C, TP\}$, i.e., $[C [Mary\ saw\ [who\ two\ boys]\ yesterday]]$ by probing of C bundled with

-
- c. Mary's the person who_i called $_i$ up [after meeting with $_i$].
 - d. John filed $_i$ [without reading $_i$] a recent article about Amazonian frogs_i.

(Nissenbaum (2000: 543))

The parasitic gap constructions shown above have in common a matrix ν P configuration “which makes the parasitic gap not only possible but obligatory (Nissenbaum (2000: 543)).”

Nissenbaum (1998a, b) claims that by raising of XP to an outer Spec, ν P, the semantic composition is made possible for the clausal adjuncts to modify ν Ps. The lower segment of ν P turns into a derived predicate, which is interpreted as a λ -abstract that binds variable in the base position of the raised XP. The two predicates, the lower ν P and the adjunct, compose by Predicate Modification, and the result applies to the raised XP by Function Application. Nissenbaum (2000) also claims that λ -abstraction is simply an interpretive reflex of a configuration involving a chain. As long as the appropriate configuration is possible to derive, the existence of the parasitic gap is predicted.

[EF], as illustrated in (33iv).

- (33) iii. {Case, {two, boys}} / {who, {Case {two, boys}}}
 iv. {Case, {two, boys}} / {{who, {Case {two, boys}}}, {C^[EF], TP}}

Then, the two sets are combined via Pair-Merge as illustrated in (33v).

- (33) v. <{Case, {two, boys}}, {{who, {Case {two, boys}}}, {C, TP}}>

...

Finally, Case of the matrix, which is dominant at the application of Pair-Merge in (33v), forces the application of Internal Merge of NumP with the pair-merged object, as shown in (33vi).

- (33) vi. {{two, boys}, <{Case, {two, boys}}, {{who, {Case {two, boys}}}, {C, TP}}>}

In the matrix clause, the set in (33vi) undergoes further application of set-formation, as shown in (33vii).

- (33) vii. ... {the, {{two, boys},
 <{Case, {two, boys}}, {{who, {Case {two, boys}}}, {C, TP}}>}}

The convergent derivation involves none of the following: any operations other than Merge, any application of Merge targeting non-root elements, nor any probing into a non-sister domain.

4. Sharing Structure and Reconstruction Effects

In this section, let us look at how the DP-internal multi-dominance analysis presented in this paper accounts for the possibility of reconstruction facts. Look at the example shown in (34).

- (34) Which argument [of Mary's] [that John_i had criticized] did he_i omit *e* in the final version?
 (Sauerland (2003: 208))

Recall that in $\langle \alpha, \beta \rangle$ α is spelled out where β is via SIMPL. Under the DP-internal multi-dominance analysis of restrictive relative structures, relative clauses are adjoined to CaseP of the matrix DP layer. In (34), then, the relative clause is interpreted only at the surface position of the fronted *wh*-Head Noun. Only adjuncts show the absence of the reconstruction effects, but the complement of the fronted *wh*-Head Noun is interpreted in the gap position. This is shown in (35).

- (35) * Which argument [of John_i's] [that Mary had criticized] did he_i omit *e* in the final version?
 (Sauerland (2003: 208))

In (35), therefore, the proper name *John* contained in the complement of the fronted *wh*-phrase induces Condition C violation.

In our analysis of restrictive relative structures, the relative clauses are just adjoined at CaseP and are not interpreted there before SIMPLE, while the shared NumP which contains PP complements (of NP) can be reconstructed at any position of the copies in (34)-(35). In the case of (34), therefore, there are no NumPs which do not violate Condition C, as illustrated below.

(34)'

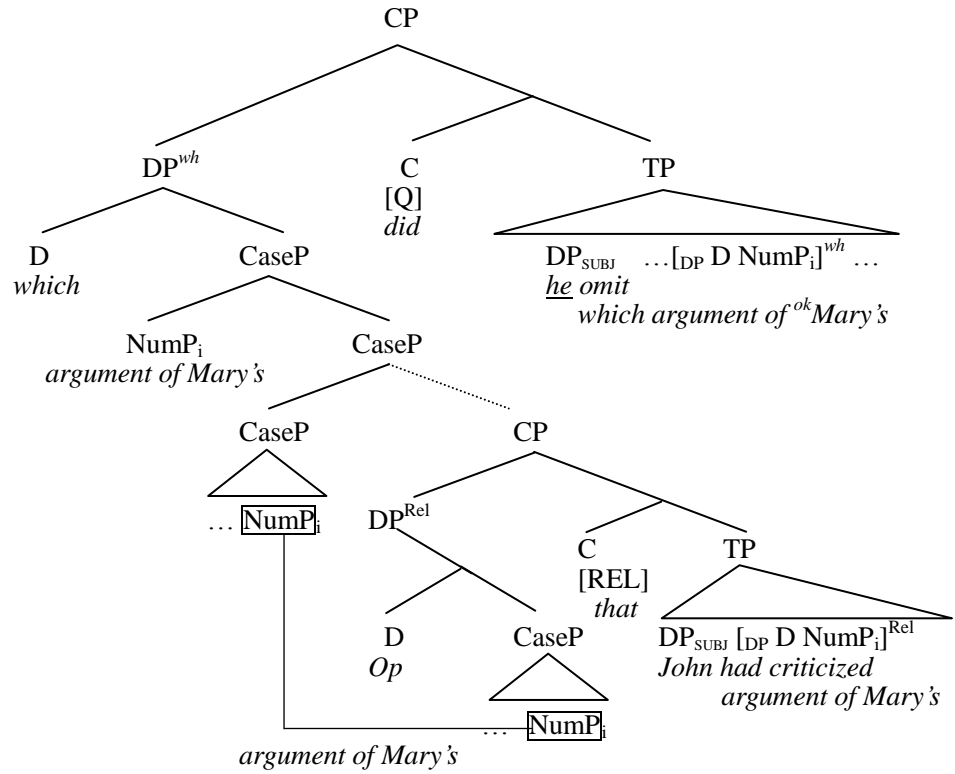

In the case of (35), on the other hand, the NumP (in boldface) in the base position of *wh*-movement in the matrix TP violates the condition, as illustrated below.

(35)'

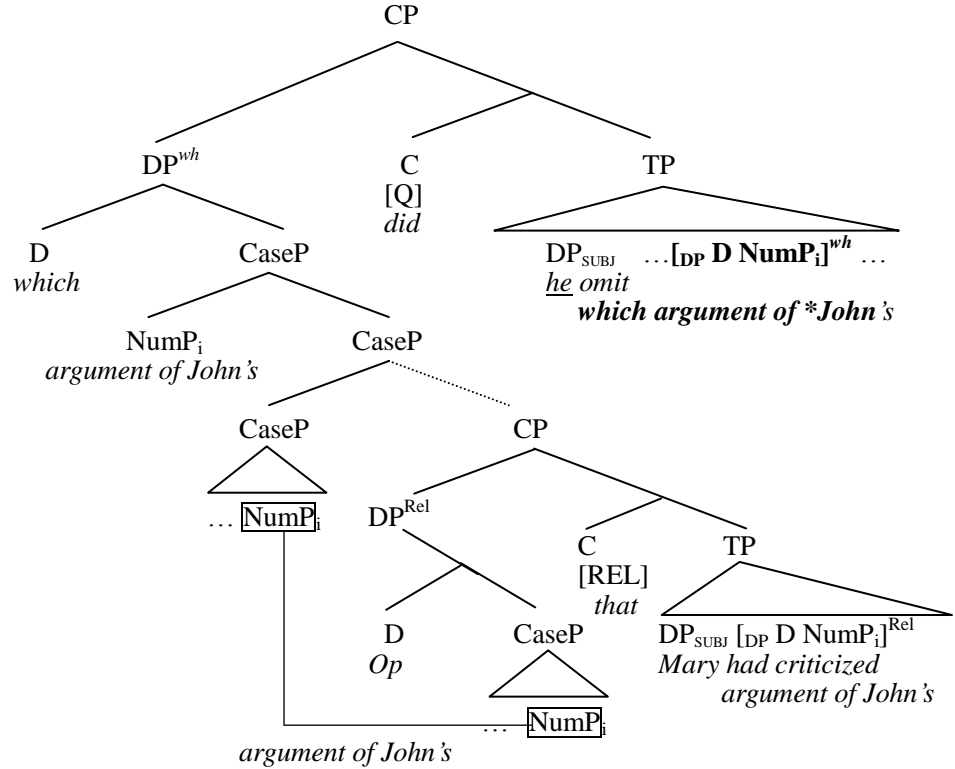

The DP-internal multi-dominance structure with a shared NumP in our analysis can also explain the reconstruction effects of the Head Nouns exemplified in (36).

- (36) a. Mary likes [a picture of himself_i [that John_i took *e* last year]].
 b. * Mary likes [a picture of John_i [that he_i took *e* last year]].

In (36) the idiomatic expression *take picture* forces the shared NumP to be interpreted at the position inside the relative clause, where it is bound by the embedded subject *John/he*. The reconstruction of the Head Noun (shared NumP) is forced for the idiom interpretation. Then, the proper name *John* contained in the complement of the Head Noun in (36b) induces Condition C violation. This is illustrated as follows.

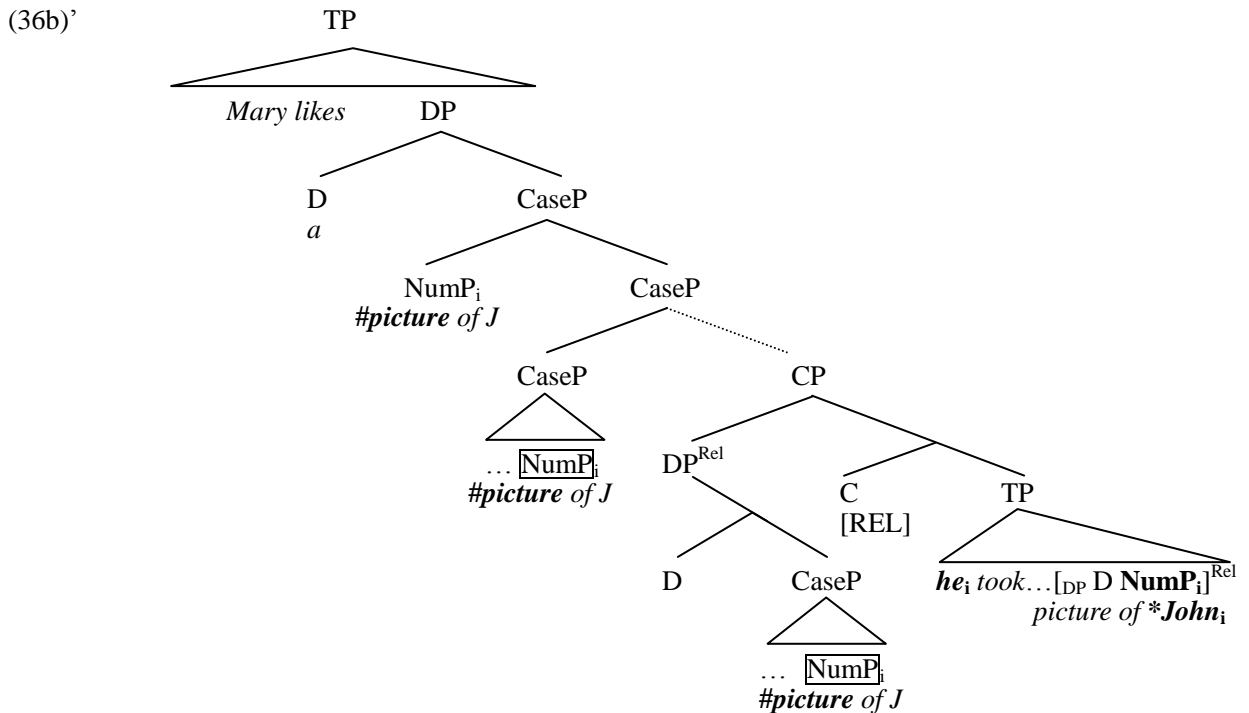

As a result, there are no NumPs in (36b) which satisfies both the adjacency requirement for idiom interpretation and Condition C.

So far it is shown that the absence of the reconstruction of the relative clause in the A'-movement of the *wh*-Head Noun is accounted for via the adjunction structure, and the reconstruction effect (and forced Condition C violation) of the Head Noun is accounted for by the interpretation of the one of the copies of the shared NumP.

It is worth pointing out that reconstruction of a shared NumP is not applied obligatorily if the application is not forced. Consider the examples in (37).

- (37) a. The relative of John_i [that he_i likes *e*] lives far away.
 b. The relative of his_i [that everybody_i likes *e*] lives far away. (Munn (1994: 402))

Notice that both (37a) and (37b) are acceptable. In (37a) the Head Noun does not show the reconstruction effect for Condition C because it does not have to do so, whereas in (37b) it shows Condition A reconstruction (variable binding) because it is allowed to.

In this respect, the reconstruction effects of the Head Nouns are not the same with the reconstruction effects of the fronted *wh*-phrases. The reconstruction in the former case is optional unless it is forced whereas the one in the latter is obligatory even though it induces ill-formedness.

- (38) a. * Which picture of John_i did he_i see *e* ?
 b. * <which picture [of John_i]> did he_i [see <which picture [of John_i]>]

In (38) the fronted *wh*-phrase *which picture of John* is reconstructed obligatorily even though the interpretation at the gap position yields the violation.

Sauerland (2003) points out that, adapting Carlson’s (1977) analysis of two types of restrictive relative clauses, the contrast observed above in (37) and (38) is the consequence of the structural ambiguity of the restrictive relativization in English between Head-Raising and Matching. In Head-Raising relatives the restrictive relative structure is derived via “promotion” of the Head Noun from inside the relative clause (cf. Kayne (1994)). In Matching relatives, the derivation of the relative clause is analogous to that of *wh*-questions in that a phrase containing the relative operator (the “internal” Head Noun) undergoes A'-movement to the left-peripheral position and then is matched with the surface Head Noun (the “external” Head Noun).

- (39) a. the [*<books >* that [_{TP}I bought *<books>*]] *Head-Raising Relative*
 b. the books [*<which books>* \emptyset_C [_{TP}I bought *<which books>*]] *Matching Relative*

Based on the hybrid analysis, Sauerland argues that the elements pied-piped internal to the Matching relatives behave exactly the same as those in *wh*-movement. For instance, the examples in (40) show that they exhibit argument-adjunct asymmetry just like *wh*-questions in (34)-(35).

- (40) a. There’s a singer [whose picture [in John_i’s office] he_i’s very proud of].
(Sauerland (2003: 210) from Safir (1998))
 b. * There’s a singer [whose picture [of John_i’s office] he_i’s very proud of].
(Sauerland (2003: 210))

However, the hybrid analysis cannot explain the reconstruction paradox. In the hybrid analysis, the relative structures are analyzed as Head-Raising relatives ((37a)) when the Head Nouns show the reconstruction effects whereas they are analyzed as Matching relatives ((37b)) when they do not show the effects. This means that the relative clauses in (4) repeated below are instances of the Head-Raising relatives since the Head Nouns show the effects.

- (4) a. What headway [that John_i made *e*] did he_i later regret *e*?
 b. Which picture of himself_i [that John_i gave *e* to Mary_k] did she_k take *e* home?

What is problematic with the Head-Raising analysis here is that the Head Noun is assumed to be base-generated inside the relative clause as we have seen in (37a). With such a structure, the absence of the reconstruction of the relative clause at the gap position of the fronted *wh*-Head Noun remains unexplained.

Under the analysis presented in this paper the contrasts in (38) and (37) are not derived from the difference between Head-Raising and Matching, or between *wh*-movement and relativization, but are attributed to the difference between A'-movement and NumP sharing. It does not matter whether the proper name *John* is contained in the prepositional modifier in (40a) or contained in the complement in (40b). What is important here is that none of the proper names in (40) are contained in the shared NumP in our analysis, as illustrated below.¹⁸

¹⁸ Sauerland (2003) also observes that contrast in (i) which he claims shows essentially the same point.
 (i) a. Max is a prince [*<[John_i’s] description of whom>* he_i varies *< >* when spies are around].
(Sauerland (2003: 210) from Safir (1998))
 b. * Max is a prince [*<whose description [of John_i]>* he_i varies *< >* when spies are around].
(Sauerland (2003: 210))

The observation will lead us to conclude the assumption that the prenominal genitive subject in (ia) is also an adjunct to the noun *description*.

(40a)'

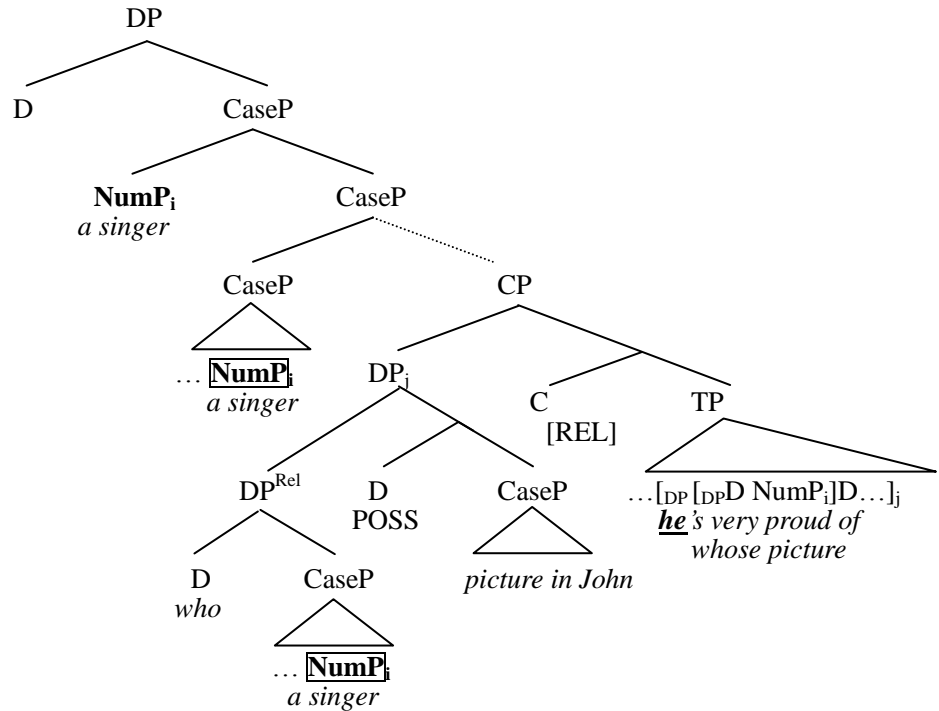

The shared NumP in (40) includes only *a singer*, and is deeply embedded inside the possessor DP at the specifier of the larger DP, which is fronted/pied-piped via A'-movement. The fronted DP is reconstructed at the base position in the relative clause obligatorily because it is derived via A'-movement. In (40a), however, the proper name *John* contained in the adjunct to the fronted DP is interpreted only at the surface position of the fronted DP. In (40b), on the other hand, the proper name is contained in the complement of the fronted DP, and A'-movement requires the complement to be interpreted at the base position of the fronted DP.

(40b)'

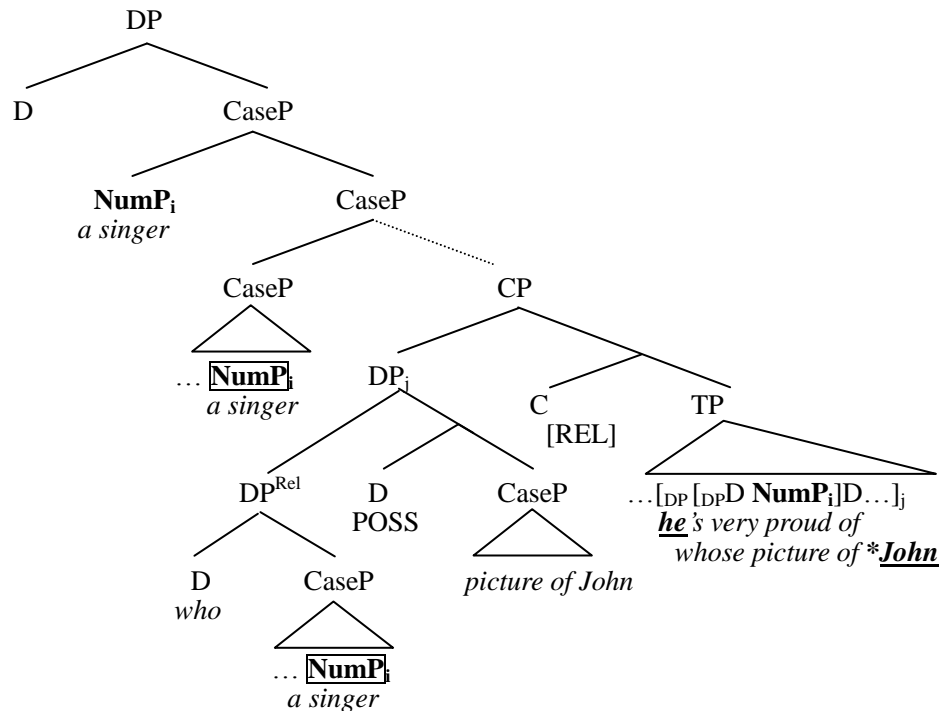

The ill-formedness of (40b) is not due to the relativization (of Matching relatives), but is caused by the obligatory reconstruction of A'-movement.

The effect of the optionality is observed again when the proper name which could induce violation is part of the Head Noun, i.e., part of the shared NumP. Consider the contrasts presented in (41).

- (41) a. * I respect any writer [whose depiction of John_i he_i'll object to]. (Sauerland (2003: 211) from Safir (1998))
 b. I respect any depiction of John_i [he_i'll object to]. (Sauerland (2003: 211))

In (41a) the shared NumP includes only *writer*, excluding the proper name *John*, whereas in (41b) it includes *depiction of John*.

(41a)'

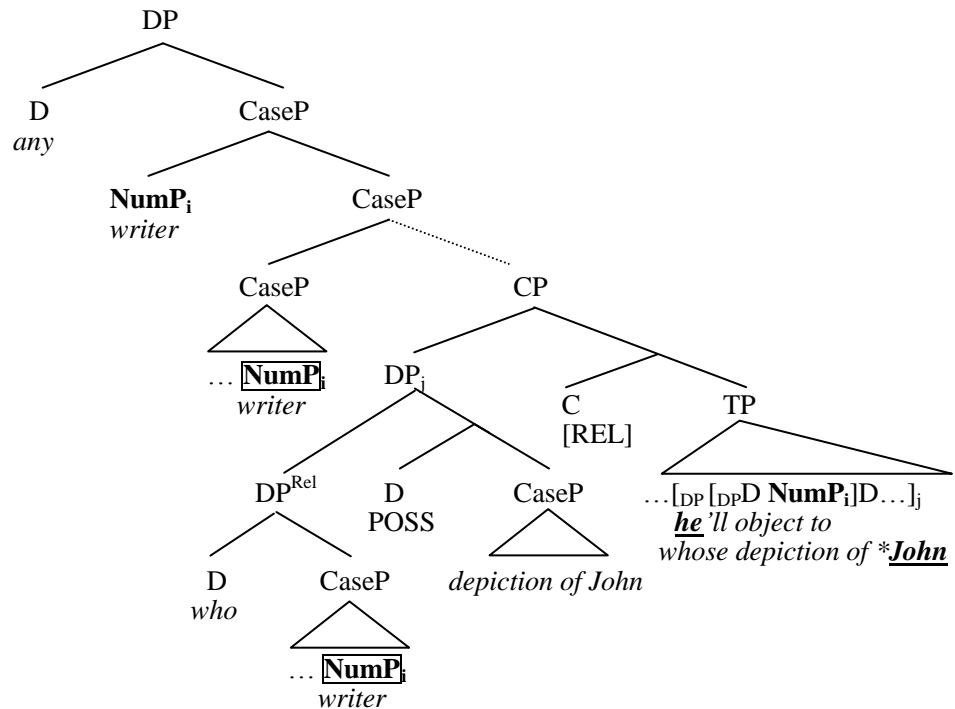

(41b)'

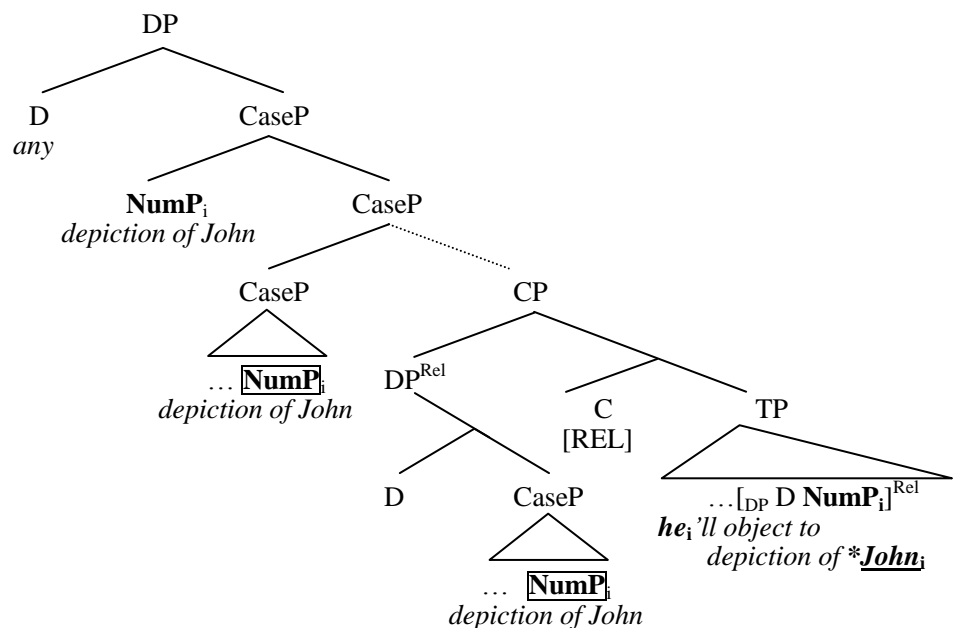

Both in (41a) and (41b), the proper name *John* is contained in the complement PP of the noun *depiction*. Notice,

however, that while the noun *depiction* is not included in the shared NumP but just pied-piped via A'-movement, it is included in the shared NumP. Again, the elements of the A'-moved phrase outside the shared NumP are forced to be interpreted at the base position, just like *wh*-questions in the same configuration.

(42) * Which report on Bob_i's division will he_i not like? (Sauerland (2003: 211))

On the other hand, any of the copies of the shared NumP can be interpreted, unless interpretation at a certain position is forced for the idiom interpretation or variable binding.

In conclusion, the reconstruction paradox constitutes no good evidence that would favor the alleged “structural ambiguity” of the restrictive relative clauses in English. Condition C violation is observed because of the obligatory reconstruction of the A'-movement/pied-piping. On the other hand, the absence of Condition C reconstruction is accounted for by the optionality of the interpretation of the shared NumP, the matter of the DP-internal syntax.¹⁹

5. Concluding Remarks

This paper has shown that a NumP movement to Spec,CaseP, which has an independent motivation in DP-internal syntactic computation irrespective of an adjunction of relative clauses, is the key factor that leads to understanding many aspects of the restrictive relative structures. The proposed analysis of restrictive relative structures is supported by the independent motivation of raising of the shared element: (i) DP-internal syntax forces raising of NumP, and (ii) A'-movement of the relative operator involving pied-piping of NumP requires the relative clause to be adjoined to the site for a proper semantic composition. It has also been shown that the proposed analysis can account for the difference in the possibility of the reconstruction between *wh*-phrases and Head Nouns, i.e., a fronted DP and a shared NumP.

References

- Abels, Klaus (2003) *Successive Cyclicity, Anti-locality, and Adposition Stranding*, Doctoral Dissertation, University of Connecticut, Storrs.
- Abney, Steven Paul (1987) *The English Noun Phrase in Its Sentential Aspect*, Doctoral Dissertation, MIT.
- Bernstein, Judy (1991) “DPs in Walloon: Evidence for Parametric Variation in Nominal Head Movement,” *Probus* 3. 101-126.
- Bernstein, Judy (1993) *Topics in the Syntax of Nominal Structure across Romance and Germanic Languages*, Doctoral Dissertation, City University of New York.
- Bianchi, Valentina (1999) *Consequences of Antisymmetry: Headed Relative Clauses*, Mouton de Gruyter, Berlin
- Brame, Michael (1968) “A New Analysis of the Relative Clause: Evidence for an Interpretive Theory,” ms., MIT.
- Cable, Seth (2010) *The Grammar of Q: Q-Particles, Wh-Movement, and Pied-Piping*, Oxford University Press, Oxford.

¹⁹ Sauerland (2003) points out Carlson (1977) and Heim's (1987) argument that only Head-Raising analysis is possible if the gap inside the relative clause is involved in a *there*-construction. Consider the contrast presented in (i).

(i) a. ?? I visited all the relatives of Mary's [that she said [there are *e* left]].
 b. I visited all the relatives of hers [that Mary said [there are *e* left]].

Carlson (1977) and Grosu and Landman (1998) also pointed out that “a [Head-Raising] analysis seems impossible when the [Head Noun] is the complement of an indefinite determiner.” The correlation between definiteness and the Head-Raising analysis is also corroborated by (ii), where” the [Head Noun] of the relative clause appears in a context that only allows an existential reading (Sauerland (2003: 215)).”

(ii) * On the table, there's {a/one} picture of herself [every girl sent *e*].

In our proposal, however, it would be the case that the matrix existential construction in (ii) forces the anti-reconstruction of the indefinite Head Noun. As shown in (iii) the amount reading of the Head Noun will favor the reconstruction so that it is interpreted in the embedded existential construction.

(iii) a. * It would have taken us all year to read the letters for John [he expected [there would be *e*]].
 b. It would have taken us all year to read the letters for him [John expected [there would be *e*]].

(Sauerland (2003: 215))

The analysis needs further investigation and will be another topic for future research.

- Cann, Ronnie (1999) "Specifier as Secondary Heads," *Specifiers: Minimalist Approaches*, ed. by David Adger, Susan Pintzuk, Bernadette Plunkett, and George Tsoulas, 21-45, Oxford University Press, Oxford.
- Carlson, Greg (1977) "Amount Relatives," *Language* 53, 520-542.
- Chierchia, Gennaro and Sally McConnell-Ginet (2000) *Meaning and Grammar*; second edition, MIT Press, Cambridge, MA.
- Chomsky, Noam (1986) *Knowledge of Language*, Praeger, New York.
- Chomsky, Noam (1995) *The Minimalist Program*, MIT Press, Cambridge, MA.
- Chomsky, Noam (2000) "Minimalist Inquiries: The Framework," *Step by Step: Essays on Minimalist Syntax in Honor of Howard Lasnik*, ed. by Roger Martin, David Michaels and Juan Uriagereka, 89-155, MIT Press, Cambridge, MA.
- Chomsky, Noam (2001) "Derivation by Phase," *Ken Hale: A Life in Language*, ed. by Michael Kenstowicz, 1-52, MIT Press, Cambridge, MA.
- Chomsky, Noam (2004) "Beyond Explanatory Adequacy," *The Cartography of Syntactic Structures vol.3: Structures and Beyond*, ed. by Adriana Belletti, 104-131, Oxford University Press, Oxford.
- Chomsky, Noam (2008) "On Phases," *Foundational Issues in Linguistic Theory*, ed. by Robert Freidin, Carlos P. Otero and Maria Luisa Zubizarreta, 133-166, MIT Press, Cambridge, MA.
- Cinque, Guglielmo (2015) "Three Phenomena Discriminating between "Raising" and "Matching" Relative Clauses," *Semantics-Syntax Interface* 2(1), 1-27.
- Citko, Barbara (2005) "On the Nature of Merge: External Merge, Internal Merge, and Parallel Merge," *Linguistic Inquiry* 36, 475-496.
- Citko, Barbara (2011) *Symmetry in Syntax: Merge, Move, and Labels*, Cambridge University Press, Cambridge.
- Fox, Danny and Jon Nissenbaum (1999) "Extraposition and Scope: a Case for Overt QR," *Proceedings of the 18th West Coast Conference on Formal Linguistics*, ed. by Sonya Bird, Andrew Carnie, Jason D. Haugen and Peter Norquest, Cascadia Press, Somerville, MA.
- Freidin, Robert (1986) "Fundamental Issues in the Theory of Binding," *Studies in the Acquisition of Anaphora*, Vol. 1, ed. by Barbara Lust, 151-188, Reidel, Dordrecht.
- Gärtner, Hans-Martin (2002) *Generalized Transformation and Beyond: Reflections on Minimalist Syntax*, Akademie Verlag, Berlin.
- Goodall, Grant (1987) *Parallel Structures in Syntax: Coordination, Causatives and Restructuring*, Cambridge University Press, Cambridge.
- Grosu, Alexander and Fred Landman (1998) "Strange Relatives of the Third Kind," *Natural Language Semantics* 6, 125-170.
- Harris, Jesse A. (2008) "On the Syntax and Semantics of Heim's Ambiguity," *Proceedings of the 27th West Coast Conference on Formal Linguistics*, ed. by Natasha Abner and Jason Bishop, 194-202, Somerville, MA.
- Inada, Shunichiro (2008) "Unexpected Narrow Scope and Reconstruction into Relative Clause," *Linguistic Research: Working Papers in English Linguistics* 24, 1-11, University of Tokyo English Linguistics Association.
- Inada, Shunichiro (2016) "Toward a Unified Account for Restrictive Relative Structures at the Syntax-Semantics Interface," paper presented at GLIM, Tsuda College.
- Kayne, Richard (1994) *The Antisymmetry of Syntax*, MIT Press, Cambridge, MA.
- Koopman, Hilda (2000) *The Syntax of Specifiers and Heads: Collected Essays of Hilda J. Koopman*, Routledge, London.
- Larson, Bradley (2009) "Ellipsis Does, but Right-node Raising Doesn't, Involve Deletion," paper presented at GLOW 32, Nantes, France.
- Lebeaux, David (1990) "Relative Clauses, Licensing, and the Nature of Derivation," *NELS* 20, 318-332.
- Lebeaux, David (1991) "Relative Clauses, Licensing, and the Nature of the Derivation," *Perspectives on Phrase Structure: Heads and Licensing (Syntax and Semantics 25)*, ed. by Susan Rothstein and Margaret Speas, 209-239, Academic Press, New York.

- Mayr, Clemens and Viola Schmitt (2009) "Order and the Coordinate Structure Constraint," ms., Harvard University and Universität Wien.
- McCawley, James D. (1981) "The Syntax and Semantics of English Relative Clauses," *Lingua* 53, 99-149.
- McCawley, James D. (1982) "Parentheticals and Discontinuous Constituent Structure," *Linguistic Inquiry* 13, 91-106.
- Nissenbaum, Jon (1998a) "Derived Predicates and the Interpretation of Parasitic Gaps," *Proceedings of West Coast Conference on Formal Linguistics* 17, ed. by Susan Blake, Eun-Sook Kim and Kimary Shahin, 507-521, CSLI Publications, Stanford.
- Nissenbaum, Jon (1998b) "Movement and Derived Predication: Evidence from Parasitic Gaps," *The Interpretive Tract (MIT Working Papers in Linguistics 25)*, ed. by Uli Sauerland and Orin Percus, 247-295, Cambridge, MA.
- Nissenbaum, Jon (2000) "Covert Movement and Parasitic Gaps," *NELS* 30, 541-555.
- Partee, Barbara and Mats Rooth (1983) "Generalized Conjunction and Type Ambiguity," *Meaning, Use, and Interpretation of Language*, ed. by Rainer Bäuerle, Christoph Schwarze and Arnim von Stechow, 360-383, Walter de Gruyter, Berlin.
- Phillips, Colin (1996) *Order and Structure*, Doctoral Dissertation, MIT.
- Picallo, M. Carme (1991) "Nominals and Nominalization in Catalan," *Probus* 3, 279-316.
- Putnum, Michael T. (2007) *Scrambling and the Survive Principle*, John Benjamins, Amsterdam.
- Ritter, Elizabeth (1991) "Two Functional Categories in Noun Phrases: Evidence from Modern Hebrew," *Perspectives on Phrase Structure: Heads and Licensing (Syntax and Semantics 25)*, ed. by Susan Rothstein, 37-62, Academic Press, New York.
- Safir, Ken (1998) "Reconstruction and Bound Anaphora: Copy Theory without Deletion at LF," ms., Rutgers University.
- Safir, Ken (1999) "Vehicle Change and Reconstruction in A'-Chains," *Linguistic Inquiry* 30, 587-620.
- Salzmann, Martin (2006) *Resumptive Prolepsis: A Study in Indirect A'-dependencies*, Doctoral Dissertation, Leiden University, published by LOT.
- Sauerland, Uli (1998) *The Meaning of Chains*, Doctoral Dissertation, MIT.
- Sauerland, Uli (2003) "Unpronounced Heads in Relative Clauses," *The Interfaces: Deriving and Interpreting Omitted Structures*, ed. by Kerstin Schwabe and Susanne Winkler, 205-226, John Benjamins, Amsterdam.
- Sauerland, Uli (2004) "The Interpretation of Traces," *Natural Language Semantics* 12, 63-127.
- Schachter, Paul (1973) "Focus and Relativization," *Language* 49, 19-46.
- Sproat, Richard and Chilin Shih (1991) "The Cross-linguistic Distribution of Adjective Ordering Restrictions," *Interdisciplinary Approaches to Language: Essays in Honor of S.-Y. Kuroda*, ed. by Carol Georgopoulos and Roberta Ishihara, 565-593, Kluwer, Dordrecht.
- Starke, Michal (2001) *Move Dissolves into Merge: A Theory of Locality*, Doctoral Dissertation, University of Geneva.
- Stroik, Thomas (2009) *Locality in Minimalist Syntax*, MIT Press, Cambridge, MA.
- Szabolcsi, Anna (1983) "The Possessor that Ran Away from Home," *The Linguistic Review* 3, 89-102.
- Thompson, Sandra A. (1971) "The Deep Structure of Relative Clauses," *Studies in Linguistic Semantics*, ed. by Charles J. Fillmore and D. Terence Langendoen, 78-94, Holt, Rinehart and Winston, New York. Reprinted in *Syntactic Argumentation*, 1979, ed. by Emily Norwood Rando and Donna Jo Napoli, 109-126, Georgetown University Press, Georgetown.
- Vergnaud, Jean-Roger (1974) *French Relative Clauses*, Doctoral Dissertation, MIT.
- Vicente, Luis (2009) "A Note on the Copy vs. Multidominance Theories of Movement," *Catalan Journal of Linguistics* 8, 75-97.
- de Vos, Mark and Luis Vicente (2005) "Coordination under Right Node Raising," *Proceedings of Twenty-Fourth West Coast Conference on Formal Linguistics*, ed. by John Alderete, Chung-hye Han and Alexei Kochetov, 97-104, Cascadilla Press, Somerville, MA.

- de Vries, Gertrud (1992) *On Coordination and Ellipsis*, Doctoral Dissertation, Katholieke Universiteit Brabant, Tilburg.
- de Vries, Mark (2006) "Possessive Relatives and (Heavy) Pied-Piping," *Journal of Comparative Germanic Linguistics* 9, 1-52.
- de Vries, Mark (2009) "On Multidominance and Linearization," *Biolinguistics* 3-4, 344-403.
- Watanabe, Akira (2006) "Functional Projections of Nominals in Japanese: Syntax of Classifiers," *Natural Language and Linguistic Theory* 24, 241-306.
- Watanabe, Akira (2008) "The Structure of DP," *The Oxford Handbook of Japanese Linguistics*, ed. by Shigeru Miyagawa and Mamoru Saito, 513-540, Oxford University Press, Oxford.
- Wilder, Chris (1999) "Right Node Raising and the LCA," *Proceedings of the 18th West Coast Conference on Formal Linguistics*, ed. by Sonya Bird, Andrew Carnie, Jason D. Haugen and Peter Norquest, 586-598, Cascadia Press, Somerville, MA.
- Williams, Edwin (1978) "Across-the-board Rule Application," *Linguistic Inquiry* 9, 31-43.
- Zamparelli, Roberto (1995) *Layers in the Determiner Phrase*, Doctoral Dissertation, University of Rochester.