

Analysis and evaluation of transmission characteristic of intra-person human body communication by the number of contact electrodes of transmitter and receiver

47-186708 Senlian Sang
Supervisor: Prof. Ken Sasaki

Human body communication (HBC) is a kind of wireless communication that uses the human body as transmission medium for high-frequency signals. Low power consumption is its main advantage. However, HBC highly depends on the condition of the devices and the environment. In this study, the influence of the number of contact electrodes of transmitter and receiver was analyzed and evaluated by simulation and experiment. The transmission characteristic of the one-electrode and two-electrode devices according to the receiver's wearing position, user's posture and the noise from the environment were investigated. As a result, a one-electrode receiver was suitable for communication to the extremity of the human body such as ankle, and a two-electrode receiver was suitable for communication to the upper arm or chest. Transmission mechanism was qualitatively described by examining the electric field distribution and the signal path by simulation.

Key words: Human Body Communication, Electric Field Analysis, Wireless Body Area Network

1 Introduction

Human Body Communication (HBC) is a kind of wireless communication which uses human body and capacitive couplings around the human body as the transmission medium. Because of the advantages such as low power consumption and high security, HBC is becoming a promising candidate for health care system. Especially the HBC used on one person which is called intra-person HBC is widely used in medical field.

However, HBC highly depends on the condition of the devices and the environment. The transmission gain would change due to the assignment of the electrodes of the receiver and the transmitter¹⁾. Bigger copper ground receiver electrode worked better for intra-person HBC²⁾. Ground electrodes of the wearable devices with more sides helped reduce the channel loss when transmitting the signal through the arm³⁾.

On the other hand, only a few studies have been conducted on the device placement except the arm. Besides, the influence of the number of the contacting electrodes of the devices for intra-person HBC has not been investigated as well. Therefore, studies on the device placement and the electrode arrangement are necessary.

In this paper, the effect of the number of the devices' contacting electrodes according to the signal attenuation was discussed. Considering the practical application for intra-person HBC, three situations: wearing the receiver at different parts of the body, doing various postures, and using HBC with the noise in the environment were analyzed through simulation and experiment.

2 Transmitter and receiver

2.1 Transmitter

Model of transmitter used in simulation is shown in Fig. 2.1. One-electrode transmitter consists of a signal

source, a signal electrode, a floating ground, and a resistor. Two-electrode transmitter is similar to one-electrode transmitter, but has a ground electrode which is in contact with the human skin. This ground electrode is connected to the floating ground.

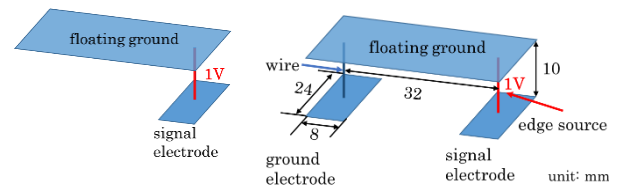

(a) 1-electrode transmitter (b) 2-electrode transmitter

Fig. 2.1 Model of the transmitter

In simulation, the source voltage is set to 1 V. The resistor is set to 50Ω , which is the standard output impedance of a signal source. The frequency is set to 21 MHz according to IEEE 802.15.6, which is widely used in medical and healthcare field.

In experiment, the source voltage is set to 1 V, and the frequency is set to 20 MHz. The circuit of the two-electrode transmitter is shown in Fig. 2.2.

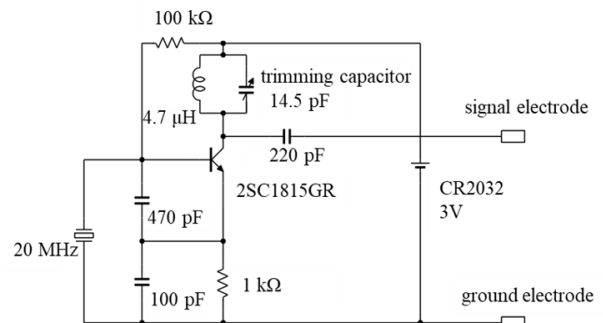

Fig. 2.2 Circuit of the two-electrode transmitter

2.2 Receiver

Models of the one-electrode and the two-electrode receivers are shown in Fig. 2.3, which have the similar structure with the transmitter. In simulation, the

resistor R_{rx} is set to 2000Ω to receive the signal.

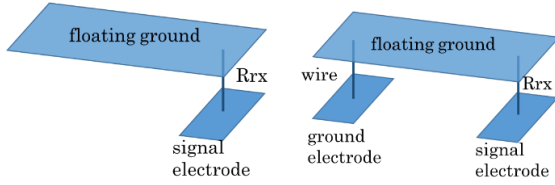

Fig. 2.3 Model of the receiver

In experiment, the receiver consists of an amplifier circuit and a comparator circuit, as shown in Fig. 2.4. The log response of the amplifier at 20 MHz can be calculated by equation (1).

$$V_{output} = 0.2144 \times \ln(V_{input}) + 2.1843 [V] \quad (1)$$

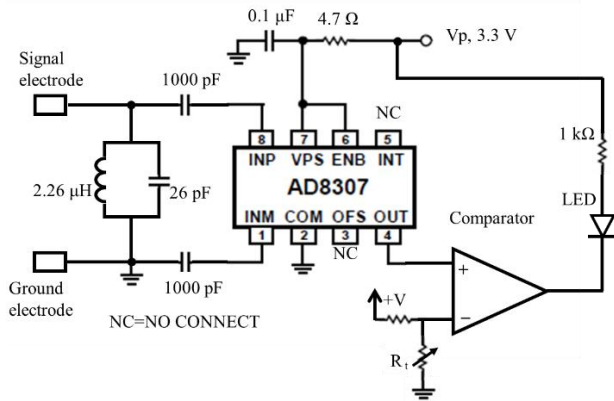
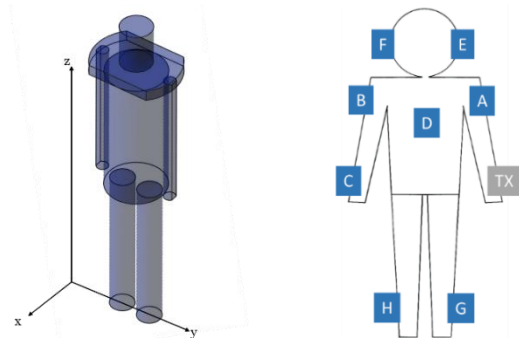

Fig. 2.4 Circuit of the two-electrode receiver

3 Influence of the receiver's wearing position

3.1 Results according to the receiver's wearing position

Model of the human body is made up of 7 parts: head, torso, shoulder, two arms and two legs, as shown in Fig. 3.1 (a). The whole human body is modeled as uniform muscle. The electrical conductivity and the relative permittivity are set to the values of muscle at 21 MHz, which are 0.6445 S/m and 107.899 respectively.



(a) Model of human body (b) Wearing position of the receiver
Fig. 3.1 Model of the human body

The transmitter is worn at the left wrist. The receiver's wearing positions are: (A) left upper arm, (B) right upper arm, (C) right wrist, (D) chest, (E) left ear, (F) right ear, (G) left ankle, and (H) right ankle, as

shown in Fig. 3.1 (b).

The signal attenuation when the receivers were worn at different parts of the body is shown in Fig. 3.2.

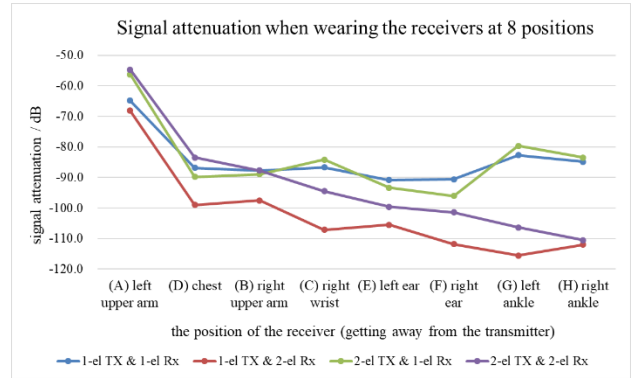

Fig. 3.2 Signal attenuation of different positions

Comparison of the received signal levels at 8 wearing positions has shown that the influence of the wearing position on the one-electrode receiver was less than that on the two-electrode receiver. The maximum received signal difference was 39.82 dB for the one-electrode receiver and 55.86 dB for the two-electrode receiver.

One-electrode receiver worked better at the extremity of the human body such as right wrist, left ear, right ear, left ankle, and right ankle. On the other hand, two-electrode worked better at the middle part of the human body, such as left upper arm, right upper arm, and chest.

When wearing the two-electrode receiver, the received signal decreased as the distance between the transmitter and the receiver increased. On the other hand, variation of the received signal was small for one-electrode receiver.

3.2 Analyze of the electric field distribution

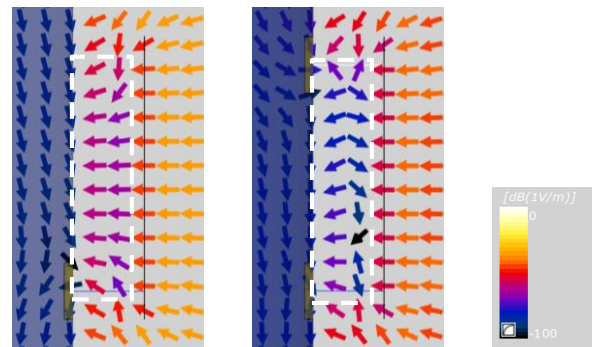

(a) 1-electrode receiver (b) 2-electrode receiver (c) Scale bar
Fig. 3.3 Signal attenuation of different positions

Fig. 3.3 indicated that the ground electrode and the wire contacting the floating ground made the transmission dependent on the coupling between the body and the receiver. Therefore, the two-electrode receiver was more affected by the wearing position.

Fig. 3.4 indicated that the signal tended to return to the body close to the two-transmitter. It was because that the ground electrode contacted with the body made

part of the human body function as the ground when wearing the two-electrode transmitter.

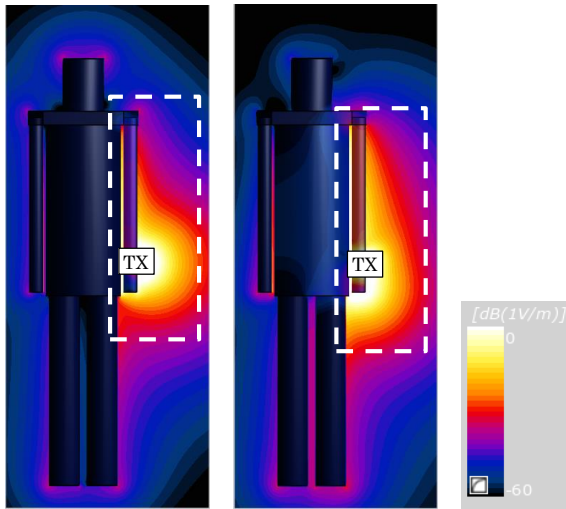

(a) 1-electrode transmitter (b) 2-electrode transmitter (c) Scale bar
Fig. 3.4 Electric field distribution around the body

4 Influence of user's posture

4.1 Influence of walking

The situation that people are moving is involved in the study to meet the needs of practical use. Model of the walking user is shown in Fig. 4.1.

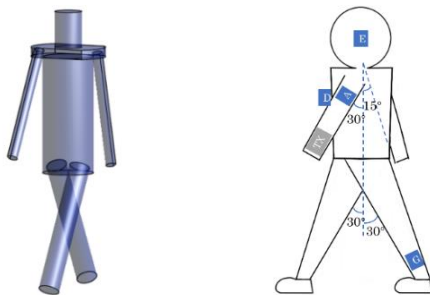

(a) Model of human body (b) Wearing position of the receiver
Fig. 4.1 Model of the walking user

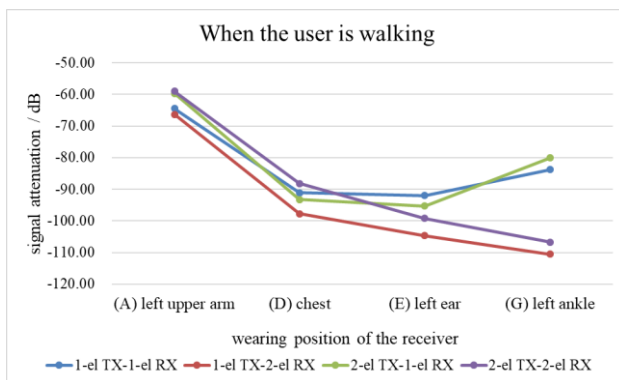

Fig. 4.2 Signal attenuation when the user is walking

The signal attenuation when the user is walking is shown in Fig. 4.2. The results of the walking situation and the standing situation were in good agreement. Two-electrode receiver worked better at the middle part

of the body and one-electrode receiver worked better at the extremity of the body.

4.2 Influence of swinging the arm

When people are walking or reaching something, they swing the arm sideways and frontward as shown in Fig. 4.3. Two-electrode transmitter and two kinds of receivers are used in the situation of swinging the arm, since the two-electrode transmitter worked better when wearing the receiver at the left upper arm.

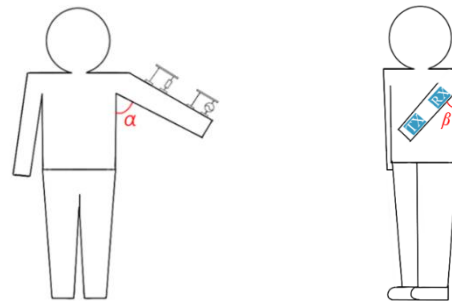

(a) Swinging arm sideways (b) Swinging arm frontward
Fig. 4.3 Swinging the arm

Signal attenuation when swinging the arm in simulation and experiment are shown in Fig. 4.4 and Fig. 4.5 respectively.

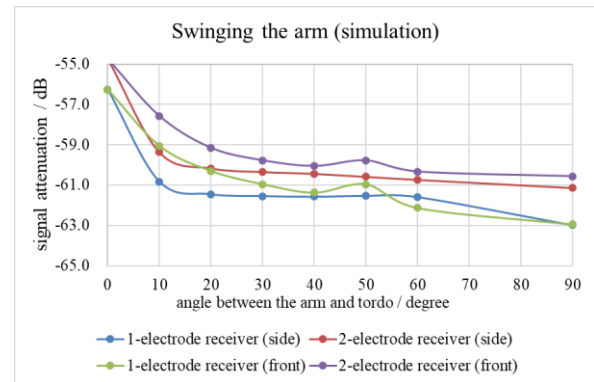

Fig. 4.4 Signal attenuation when swinging the arm in simulation

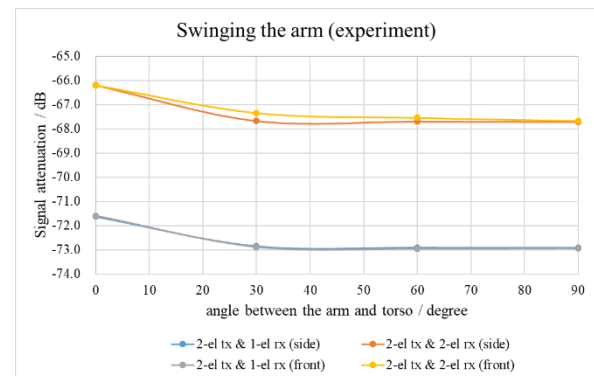

Fig. 4.5 Signal attenuation when swinging the arm in experiment

The received signal decreased as the angle between

the arm and torso increased, but it did not change much when the angle was over 30°. Besides, the received signal attenuated slower when swinging forward compared to swinging sideways in simulation.

Fig. 4.6 indicated that the received signal level was dependent of the coupling between the arm and torso when swinging the arm sideways or frontward.

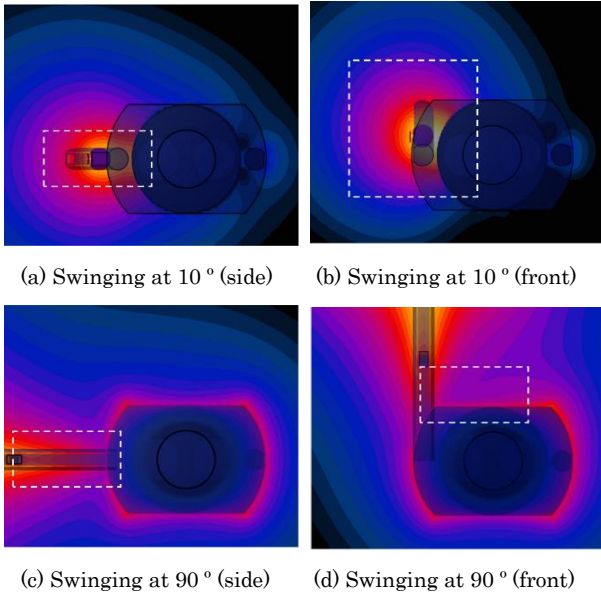

Fig. 4.6 Electric field distribution near the torso

5 Influence of the noise from the environment

The ability of anti-noise of the devices with different number of the contacting electrodes are studied in order to improve the safety performance of the intra-person HBC.

The signal attenuation when only the noise is working and when only the transmitter is working is compared in Fig. 5.1 and Fig. 5.2.

The electrode contacting condition of the receiver determined the level of the received signal from the noise when considering the receiver's wearing position.

The two-electrode transmitter and two-electrode receiver situation performed best when there was noise near the user. However, it only worked when the distance between the transmitter and receiver was close.

When wearing the one-electrode receiver, it was more reasonable to wear the receiver on the right judging by the anti-noise ability. Right upper arm was the best position, where the signal attenuation was 26.28 dB higher when the noise was switched off. Left ankle and left ear were worst positions, where the signal attenuations were 13.91 dB and 15.09 dB lower when the noise was switched off.

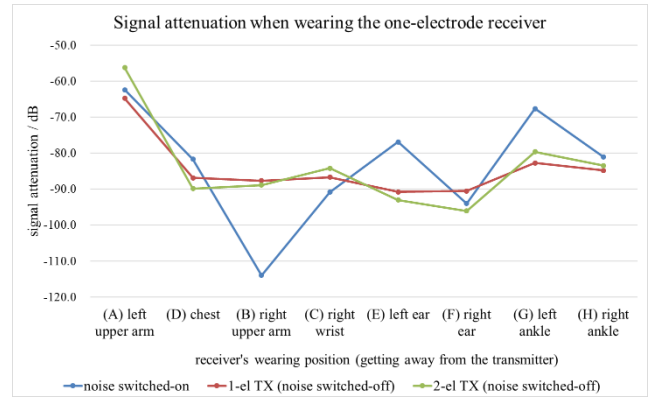

Fig. 5.1 Influence of the noise (one-electrode receiver)

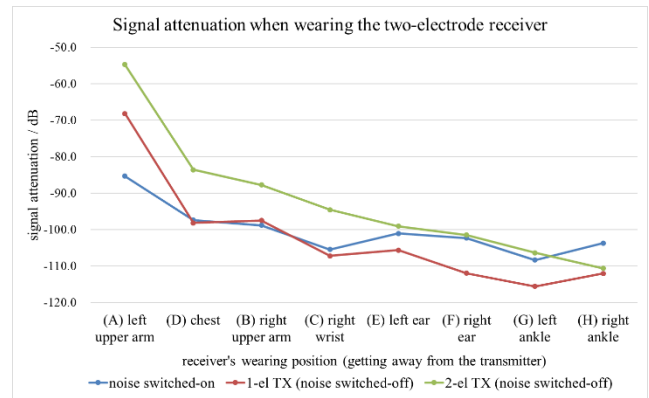

Fig. 5.2 Influence of the noise (two-electrode receiver)

6 Conclusion

In this study, transmission characteristic of intra-person HBC by the number of contact electrodes of transmitter and receiver was analyzed and evaluated. Results showed that number of receiver's contacting electrodes determined the received signal level. One-electrode receiver was suitable for the extremity of the body; two-electrode receiver was suitable for the middle part of the body. Considering the anti-noise ability, wearing the two-electrode transmitter and two-electrode receiver had the best performance.

Reference

- 1) K. Hachisuka et al., 'Signal Transmission Modeling of the Intrabody Communication and Experimental Analyses', *Journal of Japan Institute of Electronics Packaging*, vol. 10, no. 6, pp. 462–468, 2007.
- 2) M. A. Callejón et al., 'A Comprehensive Study Into Intrabody Communication Measurements', *IEEE Transactions on Instrumentation and Measurement*, vol. 62, no. 9, pp. 2446–2455, Sep. 2013.
- 3) J. Mao et al., 'An Investigation on Ground Electrodes of Capacitive Coupling Human Body Communication', *IEEE Transactions on Biomedical Circuits and Systems*, vol. 11, no. 4, pp. 910–919, Aug. 2017.