

Patents in Standards and Innovation: An  
Empirical Study on Dynamics of Essential Patents  
in Mobile Communications Standards

(標準特許とイノベーション: 移動通信標準における  
標準特許のダイナミクスに関する実証研究)

Byeongwoo Kang  
姜 秉祐

The University of Tokyo

Patents in Standards and Innovation: An Empirical Study on Dynamics of  
Essential Patents in Mobile Communications Standards

Ph.D dissertation submitted to

Department of Technology Management for  
Innovation,

The University of Tokyo

by

Byeongwoo Kang

2014

© Copyright by  
Byeongwoo Kang, 2014  
All rights reserved

## Abstract

Both patent systems and standards are aimed to encourage innovation. The patent system grants exclusive rights over the inventions that one invents, and granting the exclusive rights by the patent system is aimed to motivate an inventor to invent and collect monetary rewards from the inventions by commercializing them. A standard is a preparation to form a market and to compete. Standardization, a process to develop a standard, is a voluntary cooperative process to create a consensus-based base so that innovation can be achieved.

However, questions have been raised when technologies necessary to use a standard are protected by patents. Those patents are called essential patents. Essential patents attract much attention because of their unique nature. Essential patents are patents and also a part of (technical) standards. Thus, essential patents have characteristics that patents and standards have. When technologies necessary to use a standard are protected by patents, one has to pay license fee to the owner(s) of the patents. Thus, the owner has exclusive rights over the standards through his inventions. Recent years, we observe a licensee pays billions of dollars to a licensor to reach a license agreement. The most recent case as of today happened in September 2013. Microsoft announced to pay 3.79 billion euros for Nokia's handset business and 1.65 billion euros for a 10-year license for Nokia's patents. Nokia decided to hang on to its patents. Although Nokia does not reveal specific targets, many believe that Nokia will go after other manufacturers for royalties. Thus, giant lawsuits will be followed.

Based on the background above, this thesis is inspired by a question, '*Do patents in standards encourage innovation.*' The question is the one underlain throughout this thesis. However, this question is too broad. The discussion is ongoing in various points of view, and it is impossible to answer the question from all the existing points of view in this study. Thus, I narrow down the discussion by aiming at understanding the dynamics of patents in standards. Specifically, I will try to answer from two points of view with in depth analyses.

Question 1: How do firms obtain patents in standards in standardization?

Question 2: What are the afterward benefits of having patents in standards?

To address the question, this study provides better understanding of the dynamics of essential patents. To address the question, this study focuses on two perspectives: the standardization and subsequent effects of the standardization. The former perspective addresses firms' efforts to obtain essential patents, and it is discussed in Chapter 3 and Chapter 4. The latter perspective addresses subsequent benefits of the participation in standardization, and it is discussed in Chapter 5 and Chapter 6. In detail, Chapter 3 shows firms' efforts to obtain essential patents and inventors' involvement in standardization process. Chapter 4 presents an in-depth investigation on the standardization process whether firms' efforts are opportunistic or not. Chapter 5 investigates how an effort of a firm in standardization contributes to subsequent R&D as a part of innovation in the mobile communications industry. Finally, Chapter 6 shows Asian countries' efforts in the standardizations to raise issues given to China and Korea as followers in the standardization.

The study shows the patents in standards are not working properly to push innovation. Findings in Chapter 3 and Chapter 4 clearly show that firms try to make a standard so as to leverage their business and behave opportunistic to get essential patents. In this way, a standard cannot be a common technological base to push further innovation in the industry. In addition, Chapter 5 shows that although many manufacturers participate in the standardization and most essential patents are owned by them, their R&D activity is not much related to the standard. This may imply that a manufacturer's R&D effort in the standardization is limited only to get essential patents. Finally, Chapter 6 shows the proliferation of essential patents. China and Korea have obtained a lot of essential patents quickly, but their technological contributions in the standardization turned out to be limited. This result shows the current situation of the proliferation of essential patents.

This study empirically shows the serious problems of patents in the standards to encourage innovation. The findings in this study imply that essential patents have a limitation to push innovation. The phenomena are resulted thanks to the legal powerfulness of the essential patents. As a result, firms pay too much interest in essential patents.

## Contents

Chapter 1: Introduction .....	1
1.1. The Evolution of Technical Standards in the Mobile Communications Industry - the Background Story .....	1
1.2. Background and Theory .....	3
1.2.1. Patents and Innovation .....	3
1.2.2. Standards and Innovation.....	5
1.2.3. Patents in Standards (Essential Patents).....	7
1.3. Research Question.....	10
1.4. Structure of the thesis.....	11
Chapter 2: Research methodology: Patent Statistics and Research Data....	14
2.1. Introduction .....	14
2.2. Patent statistics.....	14
2.2.1. Citation analysis .....	16
2.2.2. Patent counts analysis.....	18
2.2.3. Technology class analysis .....	19
2.2.4. Inventor analysis.....	21
2.3. Research data .....	22
2.3.1. Patent database .....	22
2.3.2. Essential patents database .....	24
2.3.3. 3GPP Meeting minutes .....	25
Chapter 3: Determinants of Essential Intellectual Property Rights for Wireless Communications Standards: Manufacturing firms vs. non-practicing entities .....	27
3.1. Introduction .....	27
3.2. Literature review.....	29
3.3. Hypotheses .....	30
3.4. Data.....	36
3.4.1. Patent dataset.....	36
3.4.2. Essential IPR .....	41
3.4.3. Meeting attendees.....	44
3.5. Results and Discussion .....	50
3.5.1. Regression 1 .....	50
3.5.2. Regression 2 .....	53

3.6. Conclusions and policy implications.....	57
Appendix A: Compact business history description of InterDigital, Nokia, Qualcomm, and Samsung Electronics.....	58
Chapter 4: Just-in-time inventions and the development of standards: How firms use opportunistic strategies to obtain standard-essential patents (SEPs).....	
4.1. Introduction.....	60
4.2. Existing literature on standard essential patents.....	63
4.3. Hypotheses on essential patents and the standardization process....	65
4.4. Data and findings.....	69
4.4.1 Testing the first hypothesis: Relationship between patent filing and meeting occurrence.....	70
4.4.2 Testing the second hypothesis: Does meeting participation increase likelihood of patent inclusion?.....	73
4.4.3 Testing the third hypothesis: Does the technical merit of just-in-time patents differ from other patents?.....	75
4.4.4 Explorative analysis: Who employs just-in-time strategies?.....	78
4.5. Conclusions and discussion.....	81
Appendix A: Overview of variables for regression in Section 3.4.4.....	85
Appendix B: Overview of correlations between variables in regression of Section 3.4.4.....	86
Chapter 5: The role of essential patents as knowledge input for future R&D.....	
5.1. Introduction.....	87
5.2. Hypotheses.....	89
5.2.1. Non-practicing entities.....	89
5.2.2. Chipset vendors.....	90
5.2.3. Manufacturers.....	90
5.2.4. Service providers.....	91
5.2.5. Hypothesis summary.....	91
5.3. Data and Analysis Model.....	92
5.3.1. Data.....	92
5.3.2. Analysis model.....	95
5.4. Results and Discussions.....	97

5.4.1. Essential patents as a knowledge source .....	97
5.4.2. Internal knowledge as a knowledge source .....	98
5.4.3. Result summary .....	100
5.5. Conclusions and policy implications.....	102
Appendix A: Overview of correlations between independent variables in regressions.....	105
Chapter 6: Asia’s Rise in ICT Global Standardization: Empirical Analysis of Chinese and Korean Companies in Mobile Communications Standardization .....	106
6.1. Introduction.....	106
6.2. Before the Asian Rise in ICT Global Standardization: How China and Korea gained their technological capabilities .....	107
6.2.1. Case of Korea .....	107
6.2.2. Case of China .....	109
6.3. Research Data and Methodology .....	110
6.4. Analysis.....	112
6.4.1. Number of essential patents owned by Chinese and Korean companies.....	112
6.4.2. Citation analysis of essential patents applied by China and Korea .....	114
6.4.3. Technological value of essential patents owned by Chinese and Korean companies.....	117
6.5. Conclusions, Discussion and Implications .....	120
Chapter 7: Conclusions -Summary, implications, and future research agenda- .....	123
7.1. Summary .....	123
7.2. Implications .....	125
7.3. Limitations and Future Research Agenda .....	126
Reference .....	129
Acknowledgement.....	145
About Author.....	146





## **Chapter 1: Introduction**

### **1.1. The Evolution of Technical Standards in the Mobile Communications Industry - the Background Story**

Information and Communications Technology (ICT) has achieved the most dramatic technological progress of the last decades. Its innovations have affected economic growth in various industries, none more than the mobile communications industry, which according to Adachi, 2001 and Dahlman et al., 2008, has evolved together with technical standards.

The first generation (1G) mobile communications systems were implemented in the 1980s. For example, Advanced Mobile Phone System (AMPS), Nordic Mobile Telephone (NMT), and Total Access Communication System (TACS) were developed to provide mobile communication services in the U.S. and Europe. The main service provided was voice call.

The 1990s saw 2G mobile communications systems: Global System for Mobile Communications (GSM) in Europe, Interim Standard 54 (IS-54) and IS-95 in the U.S., and Personal Digital Cellular (PDC) in Japan. Thanks to increased transmission speed, the main service shifted from voice call to data transmission. However, the transmission was limited to a small amount of data such as short texts.

In the 2000s, 3G mobile communications standards, which were not restricted to specific regions, were used as a result of efforts to develop mobile communications systems that were globally deployable. Examples are Wideband Code Division Multiple Access (WCDMA), officially a part of Universal Mobile Telecommunications System (UMTS), and CDMA 2000 systems. In order to meet the demand for faster transmission speeds, the main service provided was high data transmission for file uploads and downloads such as images.

Currently, 4G mobile communications standards are about to be implemented: Long term evolution (LTE) - Advanced and Worldwide Interoperability for Microwave Access (WiMAX)-Advanced. The main service will be very high data transmissions such as big-size file uploads and downloads. In addition, voice call, which has been a major service for decades, will be provided over IP<sup>1</sup> in 4G standards. Table 1.1 summarizes the history of innovations in the mobile communications industry.

Table 1.1 History of innovation in the mobile communications industry

	1980s	1990s	2000s	2010s
Generation	1G	2G	3G	4G
Standards	AMPS, NMT, TACS	GSM, IS54, IS95, PDC	WCDMA (UMTS), CDMA2000 EVDO	LTE-Advanced, WiMAX-Advanced
Throughput	~ 2.4 kbps	~ 64kbps	~ 2Mbps	~ 1Gbps
Main Service	Voice call	Data: Text	Data: file upload/download	Data: big file upload/download

A puzzling situation has arisen. While the standardization process is successful, there are many lawsuits between companies involved in mobile communications standards. Figure 1.1 shows the lawsuits between players in the mobile communications industry as well as the owners of patents for those standards. As the figure shows, the lawsuits are very complex. Many are still ongoing and few have been resolved, one success being the agreement between Nokia and Qualcomm in 2008. Since non-practicing entities (NPEs) such as InterDigital are not included, Figure 1.1 only represents a small proportion of these lawsuits. Considering the NPEs' active patent acquisition in this industry (Fischer et al., 2012), there must be many more ongoing lawsuits in mobile communications.

---

<sup>1</sup> Internet Protocol.

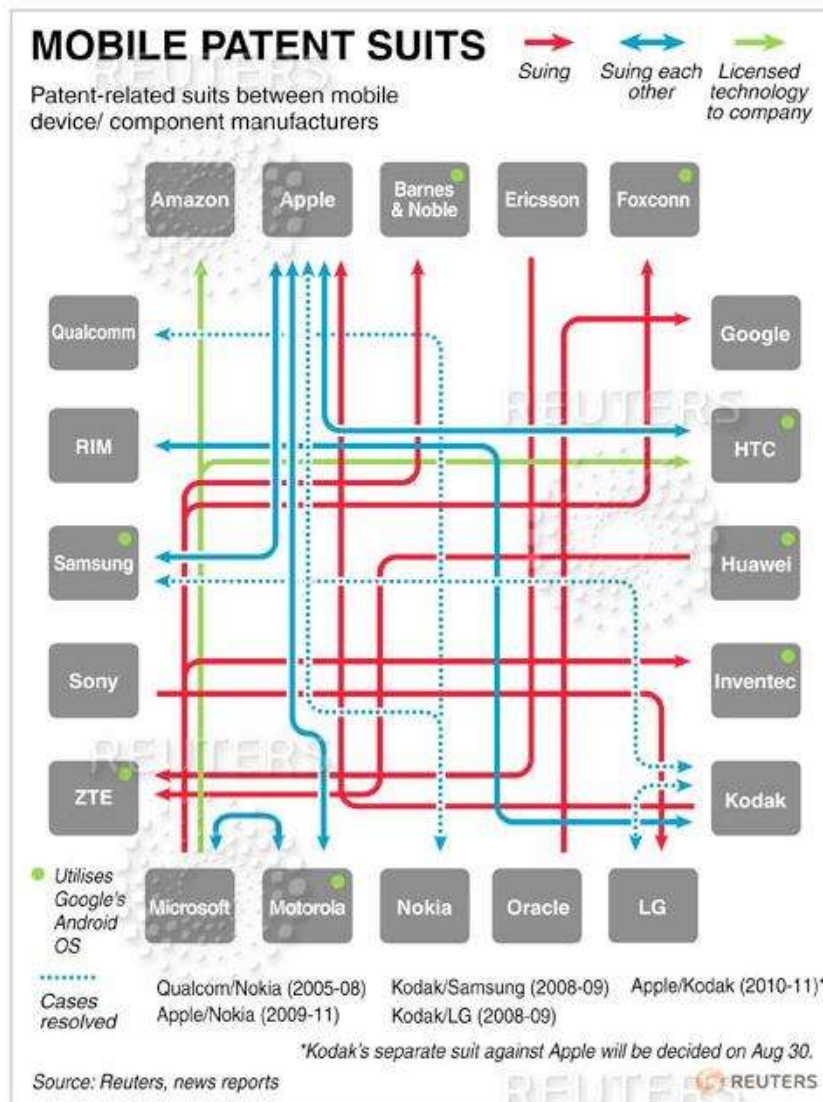

Figure 1.1. Patent lawsuits against mobile device companies  
(Source: Reuters, news reports)

## 1.2. Background and Theory

### 1.2.1. Patents and Innovation

The definition of innovation is ‘to make changes in something established, especially by introducing new methods, ideas, or products’.<sup>2</sup> Innovation studies describe a process of adding value to goods and services: ‘to make changes in something established, especially by introducing new methods, ideas, or products *in order to add value*’. Joseph Schumpeter introduced the concept of ‘innovation’, and described five

<sup>2</sup> Oxford Dictionary.

types: 1) The introduction of a new good or a new quality of a good, 2) The introduction of a new method of production, 3) The opening of a new market, 4) The acquisition of a new source of supply of raw materials or components, and 5) The reorganization of any industry.

A patent system grants exclusive rights over inventions. “Invention” and “innovation” are two different concepts, invention being the first step in innovation. Granting the exclusive rights by the patent system is meant to motivate an inventor (and/or an assignee) to invent and collect monetary rewards from inventions by commercializing them. In addition, by disclosing the inventions as a codified document, the knowledge can be transferred easily to others, which facilitates new entries to the market. In this sense, the patent system aims to encourage innovation as well as competition (Hall, 2007). The communications industry in the nineteenth century is an example of how the patent system encouraged innovation. The legal protection of inventions encouraged inventors like Charles Wheatstone, William Thomson, Alexander Graham Bell, Thomas Alva Edison, and Guglielmo Marconi, to obtain exclusive rights over their inventions, in other words block subsequent imitations, and to commercialize them (Trainer, 2007). Although inventors had to fight legal battles for their claims, the legal protection of their inventions was a driving force of radical development in communications. Their contributions to the communications industry in the nineteenth century form the basis of present-day innovations. However, the patent system did incur higher costs. Firstly, the patent system has increased transaction costs for using inventions and ideas patented by others. Secondly, although the patent term is mostly limited to 20 years, this is too long for some industries whose products have a short life cycle. The benefits and the costs of the patent system are shown in Table 1.2 (Hall, 2007).

Table 1.2. The Patent System Tradeoffs (Hall, 2007)

Effects on	Benefits	Costs
Innovation	- creates an incentive for R&D; - promotes the diffusion of ideas	- impedes the combination of new ideas & inventions; - raises transaction costs
Competition	- facilitates the entry of new small firms with limited assets; - allows the trading of inventive knowledge and markets for technology	- creates short-term monopolies, which may become long-term monopolies in network industries

There have been patent law reforms to push further innovation, but concerns have been raised at the same time (Polanyi, 1944; Kortum et al., 1998, Jaffe, 2000; Hall et al., 2001; Sakakibara et al., 2001; Gallini, 2002; Shapiro, 2004). Even in the nineteenth century, there were both pro-patent and anti-patent movements in Europe (Machlup et al., 1950), revealing how difficult it was to reach an optimal agreement for the patent system to encourage innovation. Although it is not possible to define uniform global or industry-wide patent reforms that encourage innovation, pro-patent policies or anti-patent policies can be applied, depending on the case. Empirical analyses show that a pro-patent policy is favorable for developed countries (Thompson et al., 1996; Lerner, 2002; Qian, 2007) and high-tech industries (Moser, 2005). The reason is that developing countries are trying to catch up with developed countries. However, the industries in these developing countries are already well protected by the patent system in the developed countries. Hence, a pro-patent policy is beneficial for developing countries, but only in industries that do not exist in developed countries (Diwan et al., 1991).

### 1.2.2. Standards and Innovation

The definition of ‘standard’ is ‘something used as a measure, norm, or model in a comparative evaluation’.<sup>3</sup> However, innovation studies use the word in a broader sense. In this study, we use a definition adopted by Allen et al. (2000): *Standards are documented agreements containing technical guidelines to ensure that materials, products, processes, representations, and services are fit for their purpose.*

Standards can be classified by various criteria (Allen et al., 2000). First of all, a well-recognized criterion is how a standard emerges. A *de facto* standard emerges as a result of market competition. Examples of this are the battles between Video Home System (VHS) vs. Betamax in video cassette recorders (Cusumano et al., 1992), between multiple game platforms in the home video game industry (Gallagher, et al., 2002), and High-Definition Digital Versatile Disc (HD-DVD) vs. Blu-Ray Disc for the new generation of DVDs (Gallagher, 2012). On the other hand, a *de jure* standard is created for a specific purpose and can be applied in various ways, for example by entities developing standards under an agreement like a group of companies as an alliance, or companies that are members of a standard setting organization, and so on. Also, a legislative organization, typically a government, stipulates a standard. An additional

---

<sup>3</sup> Oxford Dictionary.

criterion for classifying a standard is its purpose. The first purpose is to measure something, mostly numerically using various units. Secondly, a standard is used to describe processes such as test requirements. The third purpose is based on performance. This is when a standard is applied to guarantee a standardized quality of goods and services or to achieve interoperability between different systems.

Standardization is the process of setting a standard. It is a collaborative process between different firms, some of which are competitors in a market. Collaboration between competitors is a key requisite for successful technological innovation because resources and competences are dispersed organizationally and geographically (Teece, 1992). Technological innovation can be accelerated by effectively combining these resources. In fact, R&D collaboration has been increasing in the past decades (Hagedoorn, 2002; Gnyawali et al., 2011). The trend is significant in the high-tech sector, such as information technology, where technological innovation is developing faster than in other industries. This is mainly due to shortened product life cycles, increasing technological complexity, and an increased share of R&D expenses in the sector's total turnover (Gnyawali et al., 2009). In many cases, firms in the same industry are involved in identical issues, and each firm has complementary knowledge and assets. The collaboration with competitors enables firms to reduce unnecessary duplicated efforts in time and cost and to develop complex and sophisticated products by combining their own technologies with those of others.

A significant benefit of a standard in the innovation process is to diffuse innovation (Dunphy et al., 1996). Even if an invention is successful, its success in the market is not guaranteed. A standard helps players in the market to align their interests and to form players' networks, which consequently reduce user uncertainties about the innovation (Yoo et al., 2005). Although there are occasions when innovation is delayed or halted due to a standard such as the case of the QWERTY keyboard (Noyes, 1983; David, 1985; Farrell et al., 1986), many other examples show how standards help the diffusion of innovation (Allen et al., 2000). For example, the standardization of coinage led to technological innovation in the seventeenth and eighteenth centuries. The deployment of one single data format, Computer Aided Design (CAD) data, helped to design a high-quality jet plane, the Boeing 777 (Baba et al., 1998). In addition, proper deployment of a standard, especially in a high-tech market, provides other benefits (Tassy, 2000) such as: (1) a standard guarantees the quality and the reliability of a product and a system, (2) standardized information increases R&D efficiency, (3) a standard enables

interoperability between different complementary products, and (4) variety reduction by deploying a standard has positive effects for data formats, computer architecture, etc.

Setting standards is particularly effective in industries where a network effect prevails (Shapiro et al., 1999). The network effect appears when the benefit of a product, good, or service increases with the total number of users; the more users, the more value in a product. Industries where a network effect exists such as the railroad and (fixed/mobile) communications, deploy standards to stimulate innovations. Standards have become very important for innovation processes in ICT. Hand in hand with the increasing use of ICT in various industries, the importance of standards is also growing.

### 1.2.3. Patents in Standards (Essential Patents)

Because of the different nature of patent systems and standards, a confusing situation arises when patents are included in standards. Two sides, one private and the other public, come into conflict (see Table 1.3). Patent systems and standards are both meant to encourage innovation. As previously mentioned, a patent system grants exclusive rights over inventions,<sup>4</sup> and this is intended to motivate an inventor to invent and collect monetary rewards by commercializing the inventions. Thus, patenting activity itself is part of the innovation process. However, the term of a patent is usually 20 years. A patent expires no matter how technologically advanced and economically valuable it is. Standardization on the other hand, which aims to develop a standard, is a voluntary cooperative process to create a consensus-based guideline so that innovation can be achieved. The term of a standard is not defined because a standard is not an exclusive right. A standard is the preparation to form a market and to compete. In this sense, a standard exists not for exclusive dominance but for a public purpose.

---

<sup>4</sup> Technically speaking, the legal protection over the invention is given to the one who files first.

For more information: [http://en.wikipedia.org/wiki/First\\_to\\_file\\_and\\_first\\_to\\_invent](http://en.wikipedia.org/wiki/First_to_file_and_first_to_invent)



Table 1.3 Contradiction between a patent and a standard

	Patent	Standard
Purpose	Encouraging innovation	
Benefiter	Private (only the rights holder)	Public
Means	Granting exclusive rights of inventions	Creating a consensus-based guideline
Role	Motivating one to - invent - collect monetary rewards from the inventions	A preparation process to - form a market - compete
Term (lifetime)	(Usually) 20 years	Not defined

As we observed from the case of mobile communications, even if the development of the standards is successful, there may be legal issues preventing their use in the market. Issues can arise due to the existence of patents included in the standards. Since a technical standard can be interpreted as a set of requirements for a technological component and a system, there are cases where components of the technical standard are protected by intellectual properties, mostly patents, even if the standard itself cannot be patented. These patents, inventions which are used in standards, are called ‘essential patents’. Hence, whoever wants to make, sell, or use standards, must obtain licenses from all the owners of those patents that are necessary to implement the standards; without the licenses, they are infringing patents by the nature of patent laws. That is, there is a risk that owners can privatize the standards which contain their patents.

As shown in Figure 1.1, many firms in the mobile communications industry end up with lawsuits against competitors. Similar cases are observed in other industries, the best known case in the semiconductor industry being Rambus (JISC, 2009).

Because of the conflict between patents and standards, methods have been proposed to reduce the risks. However, each proposed method has pros and cons (Bekkers et al., 2012). Here we give a brief outline of three methods proposed until now. First, the most well-known method is fair, reasonable, and non-discriminatory (FRAND) terms. Standard setting organizations (SSOs) request essential-patent holders to commit to license their essential patents to third parties on fair, reasonable, and non-discriminatory terms. At first glance, FRAND terms seem to apply only to the essential-patent holders as potential licensors. FRAND terms must not be interpreted as essential-patent holders

having to waive their rights. If some hold essential patents as a result of early investment, their efforts must be compensated. Otherwise, no one will take the risk that early investment ends in failure, and consequently, innovation will be hampered. There is also a risk that a potential licensee abuses FRAND terms. Thus, it is a prerequisite that both potential licensors and licensees negotiate at arm's length. However, the guidelines for FRAND terms are still insufficient, and the interpretation of FRAND terms is controversial. How should we apply FRAND terms in practical licensing? This unclear definition has increased the number of lawsuits with essential patents to set FRAND terms between licensors and licensees and so costs will increase. The second proposal is patent pools, which have attracted much attention. A patent pool is an agreement between two or more patent owners to license one or more of their patents to one another or third parties (Clark et al., 2000). Although some patent pools are successful, there are concerns about who will coordinate the licensing with non-members, how to reach a license agreement between members, etc. However, many patent pools have attracted only a few owners who own just a small proportion of all the essential patents. The third proposal is voluntary ex ante licensing. This method requires the owner(s) to disclose licensing terms in public, for instance, the maximum price for licensing before any patents become essential. This method has already been adopted in SSOs, however in practice, it is not working well. No soon-to-be owners want to state their commitment to ex ante licensing terms.

Without the licenses of a standard's essential patents, the market which uses the standard cannot be formed. Thus, SSOs define the intellectual property right (IPR) policy. However, the IPR policy that each SSO enacts varies considerably.<sup>5</sup> For example, some SSOs ask their members to disclose essential patents, and others do not. However, the SSOs' IPR policy has no legal obligations and so there is no penalty for SSOs if their member companies fail to disclose this information. There are even some SSO member companies which disclose without specifying the lists of patents (Blanket disclosure). The problem with the nature of patents in standards remains unsolved.

---

<sup>5</sup>International Symposium on Standards Strategy and Intellectual Property - The Role of Patent Policies and Pools in Standardization Activities and Ways to Cope with Hold-Up Problems, December 9, 2008. Available from <http://www.jisc.go.jp/policy/kenkyuukai/ipr/sympo.html> (Last accessed May 20, 2013)

### 1.3. Research Question

Based on the background given above, this thesis is inspired by the question, ‘*Do patents in standards encourage innovation.*’ Although it underpins my entire thesis, this question is too broad. As there is an ongoing debate with varying points of view, it is impossible to address all of them in this study. Thus, I narrow down the discussion by aiming to understand the dynamics of patents in standards. Specifically, I will attempt to explain the following two perspectives by means of in-depth analyses.

Question 1: How do firms obtain patents in standards in standardization?

Question 2: What are the subsequent benefits of having patents in standards?

The first perspective, which addresses firms’ efforts to obtain essential patents in standardization, is discussed in Chapters 3 and 4. I investigate in detail firms’ strategies to obtain essential patents (Chapter 3) and the pattern of firms’ patent applications (Chapter 4). The second perspective addresses the subsequent benefits of having essential patents and is discussed in Chapters 5 and 6. Each chapter investigates the subsequent benefits of having essential patents as R&D source (Chapter 5) and as catch-up strategy (Chapter 6). The structure of the research question is shown in Table 1.4. The findings from this thesis will not only help us to understand the dynamics, generation and usage of essential patents but also provide empirical evidence to judge if the energy consumed and cost of litigation for essential patents are proper, exaggerated, or underestimated.

Table 1.4 Research question and topics covered in this study

Research Question	Do patents in standards encourage innovation?	
Topics (Chapter)	Efforts to obtain essential patents: - Firms’ strategies: Chapter 3 - Patent application: Chapter 4	Subsequent benefits of having essential patents: - R&D source: Chapter 5 - Catch-up: Chapter 6

This study conducts in-depth analyses of the case concerning Third Generation Partnership Project (3GPP). This is a collaboration of six partner organizations: Association of Radio Industries and Business (ARIB) in Japan, Alliance for Telecommunications Industry Solutions (ATIS) in the U.S., China Communications Standards Association (CCSA) in China, European Telecommunications Standards Institute (ETSI) in Europe, Telecommunications Technology Associations (TTA) in

Korea, and Telecommunication Technology Committee (TTC) in Japan. Each partner is a standardization organization that develops standards in their region. The original purpose of 3GPP was to develop third generation (3G) telecommunications standards that are applicable world-wide. As an extension of its role as globally successful standard setting organization, 3GPP continues its standardization activities in fourth generation (4G) telecommunications standards (Figure 1.4). 3GPP's standards have been adopted in most countries. As a matter of fact, alternative 3G and 4G standards are standardized in IEEE (WiMAX and WiMAX-Advanced) and 3GPP2 (cdma2000 Enhanced Voice-Data Only (EVDO), cdma2000 EVDO Revision A, and Ultra Mobile Broadband (UMB)). However, their standards have not all ultimately been adopted, and only in a few countries.

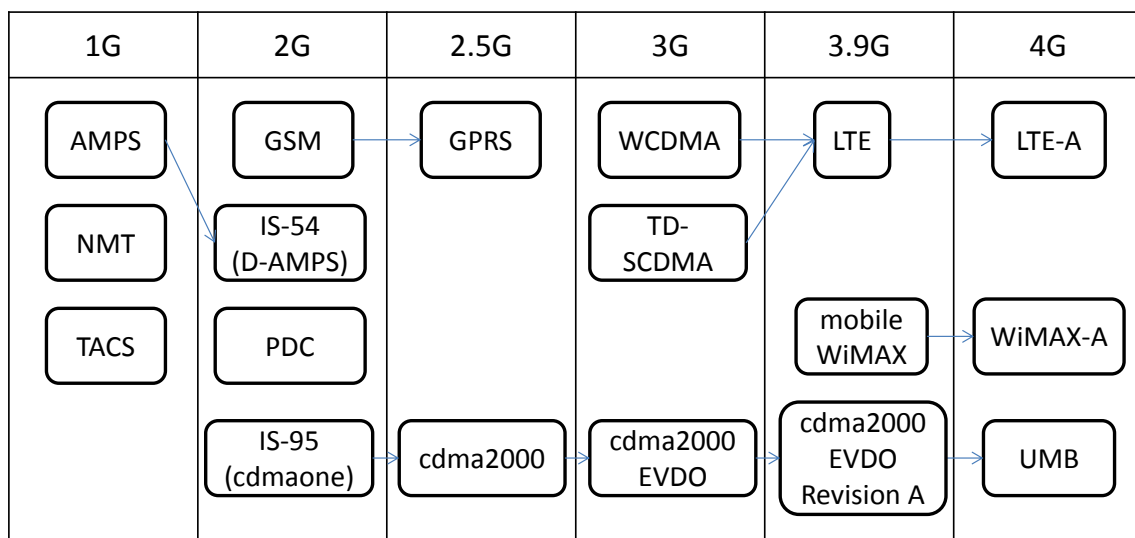

Figure 1.2. Succession of mobile communications standards

#### 1.4. Structure of the thesis

Chapter 1 is an introduction, which provides the background and the prior literature so that readers can better understand the topics discussed.

Chapter 2 describes the research methodology used in this study: (1) patent statistics and (2) data sources. This study has been conducted based on various databases, all of which are matched to a patent database. All the retrieved data matched to patent data are analyzed by applying statistical indicators, called patent statistics. Numerous patent statistics have been proposed so far, and so it is important to use them selectively, case by case. A list of the patent statistics used in this study is presented in Table 2.1.

Chapter 3 discusses a strategy for obtaining essential patents. I begin my discussion by analyzing how companies try to obtain essential patents in a standard. For the analysis, I divide firms who participate in the standardization process into manufacturing firms and non-practicing entities (NPEs). The comparison is conducted from two perspectives: (1) core competency and (2) knowledge spillovers from different sources. The latter is further divided into knowledge spillover from both a firm's own knowledge and from prior essential patents. In addition, by reviewing the standardization process, I will discuss the effect of inventors who participate in standardization meetings. To the best of my knowledge, this work is the first attempt to observe the relationship between those inventors and essential patents.

Chapter 4 contains an in-depth analysis of the standardization process. It investigates further the impact of inventors who participate in standardization meetings. This analysis helps us understand the background to the proliferation of essential patents in the industry. I conduct the analysis by identifying all meeting participants who have ever attended 3GPP standardization meetings. Specifically, I observe their patenting behaviors before each standardization meeting, during the meeting, and after the meeting. This analysis assesses whether or not there is opportunistic behavior, which will be referred to as 'just-in-time invention' in this thesis, to obtain essential patents. In addition, I assess whether or not the just-in-time inventions lead to technological merits in the standard.

Chapter 5 describes an assessment of the benefit of essential patents in terms of R&D. It details whether firms' efforts to obtain essential patents are part of their R&D strategies. I examine if the benefit of owning essential patents is limited in the standardization itself. When addressing this issue, we divide firms owning essential patents according to their business models. I categorize the firms into four types, from upstream to downstream: NPEs, Chipset vendors, Mobile terminal/Base station manufacturers, and Service operators. I observe to what degree the knowledge on essential patents affects each business model's R&D activity. For comparison purposes, other knowledge sources, internal knowledge and external knowledge are also considered in the analysis.

Chapter 6 covers the analyses of recent active participation by China and Korea in global ICT standardization. Japan is already one of the leaders and many believe that

Asia's role in global ICT standardization is increasing due to the fact that countries like China and Korea are increasingly visible in global ICT standardizations. We assess whether or not it is true that Asia's role in ICT global standardization and innovation has increased. From the analysis, we will identify future issues that China and Korea may have to overcome. In addition, we propose implications for other developing countries in Asia.

Chapter 7 concludes this thesis with a summary of the contributions, implications, and future research agenda. Study results clearly highlight issues that must be overcome to foster innovation in industries with standards containing patents, that is to say where essential patents exist.

## **Chapter 2: Research methodology: Patent Statistics and Research Data**

### **2.1. Introduction**

This chapter discusses the study's research methodology. This study is based on statistical information retrieved from the tremendous amount of patent applications. Thanks to rapid developments in the computer industry in recent decades, information can be obtained in the simple form of digitalized data. With the emergence of statistical software, the digitalized data in patent documents are transformed into statistical information, which is then used in quantitative analyses. In addition, high performing databases that enhance the processing of big data such as patent documents are also fostered in line with computer industry developments. This chapter describes two aspects: (1) the statistical indicators that can be derived from patent documents (Section 2.2), and (2) patent databases used in this study (Section 2.3).

### **2.2. Patent statistics**

The data analysis for this study is based on statistical information retrieved from a large number of patent applications, called patent statistics. Patent documents provide useful information which helps us to understand the technological innovation process (Jaffe et al., 2002). An example of the first page of a patent application is shown in Figure 2.1, illustrating what kind of information can be found. From the example, we can identify: the patent office to which the patent is applied (the United States in this example), the title, the inventors and their addresses, the assignee and their address, the application number, the publication number, the publication date, other related patent applications, the foreign application priority data, the patent classification, the abstract, and the best mode figure. Since patent is often regarded as an output of R&D, analysis of the information acquired from patent documents lets us see how R&D is conducted and how technological innovation is derived from inventions. Accordingly, dozens of patent statistics have been proposed by scholars for an effective analysis of patent data. Patent

statistics are used in various fields such as science and technology, social sciences and economics. Also, the empirical studies using the patent statistics have increased significantly in recent years. This section introduces some indicators that can be measured from the patent information and usage examples in prior studies. Table 2.1 is an overview of the patent statistics used in this paper.

Table 2.1 List of the patent statistics used in this study

<b>Analysis</b>	<b>Patent statistics</b>	<b>Proxies</b>
Citation analysis	Forward citations	Technological value
	Backward citations	Knowledge flow/spillovers
Patent counts analysis	Patent counts	Patent portfolio
	RTA (Revealed Technology Advance)	Core technological competence
	PS (Patent Share)	
Technology class analysis	Generality	Endogenous applicability to different technological fields
	Originality	Knowledge absorption from different technological fields
Inventor analysis	Inventor counts	Invention quality Absorptive capability
	Inventor	Specific inventors' info: Ex) High performing engineers





US 20120082102A1

(19) **United States**

(12) **Patent Application Publication**  
**Kang et al.**

(10) **Pub. No.: US 2012/0082102 A1**

(43) **Pub. Date: Apr. 5, 2012**

(54) **METHOD FOR INDICATING PRECODING MATRIX INDICATOR IN UPLINK MIMO SYSTEM WITH BASED ON SC-FDMA**

(30) **Foreign Application Priority Data**

Jul. 7, 2009 (KR) ..... 10-2009-0061699

(75) **Inventors:** **Byeong Woo Kang**, Anyang-si (KR); **Joon Kui Ahn**, Anyang-si (KR); **Dong Youn Seo**, Anyang-si (KR); **Jung Hoon Lee**, Anyang-si (KR); **Yu Jin Noh**, Anyang-si (KR); **Byoung Hoon Kim**, Anyang-si (KR); **Suck Chel Yang**, Anyang-si (KR); **Bong Hoe Kim**, Anyang-si (KR); **Dae Won Lee**, Anyang-si (KR)

**Publication Classification**

(51) **Int. Cl.**  
**H04W 74/04** (2009.01)  
**H04W 72/04** (2009.01)

(52) **U.S. Cl.** ..... **370/329**

(73) **Assignee:** **LG ELECTRONICS INC.**, Seoul (KR)

(57) **ABSTRACT**

A method of transmitting PMI (precoding matrix indicator) information in an uplink MIMO system is disclosed. The present invention includes the steps of receiving channel information from a user equipment and transmitting information on a resource allocated to the user equipment in uplink transmission and PMI information indicating a precoding matrix to apply to a region of the resource among a plurality of precoding matrices to the user equipment based on the received channel information, wherein the resource allocated to the user equipment is allocated by a bundle unit of a prescribed number of subcarriers, wherein each of a plurality of the precoding matrices are applied to regions generated from dividing a whole frequency band into a prescribed number of regions, respectively, and wherein the precoding matrix applied to the resource among a plurality of the precoding matrices has a maximum area resulting from overlapping a frequency band occupied by the allocated resource with a frequency band having the precoding matrix applied thereto.

(21) **Appl. No.:** **13/148,886**

(22) **PCT Filed:** **Feb. 19, 2010**

(86) **PCT No.:** **PCT/KR2010/001039**

§ 371 (c)(1), (2), (4) **Date:** **Nov. 14, 2011**

**Related U.S. Application Data**

(60) Provisional application No. 61/161,049, filed on Mar. 17, 2009, provisional application No. 61/157,206, filed on Mar. 4, 2009, provisional application No. 61/153,974, filed on Feb. 20, 2009.

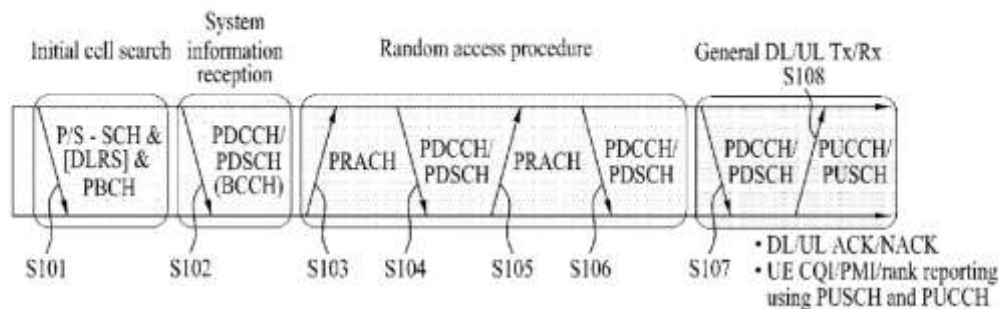

Figure 2.1 Example of a patent application (first page)

### 2.2.1. Citation analysis

A patent document provides a list of citations that are added by patent applicants and/or patent examiners (Nagaoka et al., 2010). In order to apply to the United States Patents and Trademark Office (US PTO), a patent applicant must disclose all information

and prior art cited that are material to patentability (duty of candor<sup>6</sup>). If the patent applicant fails on this, the patent application cannot be validated. Hence, most citations in the patent applications to US PTO are added by patent applicants and/or inventors. On the other hand, patent offices such as European Patent Office (EPO) and Japan Patent Office (JPO) do not regulate such obligations. In the case of patent applications to EPO, examiners search relevant prior patent and non-patent documents that help decide the patentability of the patent applications (Webb et al., 2005). Inventors are asked to indicate background details that are helpful for examiners to understand the invention.<sup>7</sup> As a result, most citations in the patent applications to EPO are added by examiners in a search report.

Forward citation is one application that uses citation analysis. Forward citation is used for measuring the endogenous technological value of a patent (Carpenter et al., 1981; Karki et al., 1997). The number of forward citations refers to the number of times a patent is cited by subsequent patent applications. The interpretation of the forward citation is that the patent must be cited in subsequent patent applications by patent applicants and/or examiners, since a patent with high technological value acts as a seed for successive inventions. However, special care is required when using forward citations. Since old patents are likely to be cited more than recently applied ones, the direct use of forward citation scores may lead to a skewed analysis result. In addition, the number of forward citations differs in application dates and technological fields. To overcome these problems, time-window and relative forward citation scores are proposed (Jaffe et al., 2002; Nagaoka et al., 2010).

Another application is backward citation, which is used in measuring knowledge flow (Fung et al., 2002; Nelson, 2009). Backward citation refers to references from prior art; not only patent documents but also non-patent literature including journal publications, standard documents, technical reports, etc. Learning is the first step to create something new, whether the learning was direct or indirect (Acs et al., 2009).<sup>8</sup> As

---

<sup>6</sup> The full text is in: “37 C.F.R. 1.56 Duty to disclose information material to patentability”.

<sup>7</sup> The European Patent Convention - Rule 42 (1) (b): *indicate the background art which, as far as is known to the applicant, can be regarded as useful to understand the invention, draw up the European search report and examine the European patent application, and, preferably, cite the documents reflecting such art.*

<sup>8</sup> If I have seen further, it is by standing on the shoulders of giants – Isaac Newton. I start where the last man left off – Thomas Edison.

it is reviewed how citations are generated in patent documents, inventors and examiners add references that contribute to the inventions in the patent application. Therefore, backward citation is useful information about what knowledge has influenced an invention. By analyzing sequences of backward citations, one can follow trajectories of knowledge flow (Bekkers et al., 2012). In addition, analysis of academic journals in backward citations helps us understand the linkage between technology and science (Narin et al., 1985; Narin et al., 1997; Callaert et al., 2006).

An additional concern in using citation analysis may arise because not only inventors, but also patent examiners add citations to a patent document. Moreover, most citations are added by the examiners rather than the inventors (Alcarcer et al., 2006; Criscuolo et al., 2008; Alcacer et al., 2009). Nevertheless, this concern does not apply when measuring the technological value in a patent by counting forward citations. The patent examiners determine the patentability of a patent application by finding relevant prior art. Even if the number of forward citations in a patent document is increased mostly by the patent examiners, this increase must be interpreted as the examiners themselves trying to attain technologically valuable inventions. Thus, the number of forward citations represents the endogenous technological value in a patent whether the forward citations are increased by the examiners and/or by the inventors. There are concerns even though patent citation analyses are widely used to measure knowledge flow (Verspagen, 2007). However, since the patent examiners are not involved in the invention process, knowledge flow from, to, or between examiners is not of interest. In this respect, if most citations are added by examiners rather than inventors, there is a concern that knowledge flow cannot be properly measured. However, one must consider whether or not the inventors are willing to add citations when filing patent applications. There is also a risk for the inventors of nullifying their inventions by adding citations. Even if the inventors are legally required to provide the knowledge that informed their inventions (duty of candor) to a patent office, they disclose those citations that support, not block, the claims in the patent document (Hedge et al., 2008). On the other hand, examiners can discover “lost rings of the invention chain” to block the claims. And, as Fontana et al. (2009) and Martinelli (2011) also highlight the effectiveness of patent citations for measuring knowledge flows in their papers, I use patent citations to represent knowledge flow in this thesis.

### 2.2.2. Patent counts analysis

Patent counts analysis refers to counting the number of patent applications.

Patents are regarded as an output of R&D (Griliches, 1990). Firms with heavy R&D activity tend to have more patents than those with less R&D. However, not all R&D outputs are protected by means of patents because the patent system has a trade-off between the benefit of monopoly right and the risk of disclosure. For these reasons, strategies other than patents are sometimes preferred. Other strategies are secrecy, lead-time advantages, and so on (Cohen et al., 2002; Blind et al., 2004). Nevertheless, the merits of patents, such as availability of patent data and ease of quantitative analysis, greatly outweigh the drawbacks. Patent counts analysis is often conducted using other patent statistics such as technological classification.

Patent counts are used for various purposes. Firstly, a firm's patent portfolio can be measured from a patent counts analysis (Brockhoff, 1992; Ernst, 1998; Fabry et al., 2006; Lin et al., 2006). A patent portfolio helps to ascertain technological positions and benchmarking competitors. When a firm changes its technology and business strategy, their change in R&D activity is revealed in terms of patent filing, and fluctuations can be observed in certain technological fields. Work by Basberg (1982), testing patent statistics as a technology indicator in Norway's whaling industry, found technological changes from this industry's patent statistics. He also found the timings of innovations and diffusion by examining patent statistics.

Secondly, patent counts are also used to measure core competence (Prahalad et al., 1990). Revealed Technology Advance (RTA) and Patent Share (PS) are defined as two proxies for core technological competence (Narin et al., 1987; Patel et al., 1997; Granstrand et al., 1997). RTA refers to the applicant's internal ratio of a patent's share in a technological field to all the applicant's patents in those fields. On the other hand, PS refers to the ratio of a patent's share in a technological field after determining the technological distribution of all patents reported by the patent office. Therefore, a patent with high RTA and high PS is regarded as highly important inside and outside a firm, respectively. It should be noted that a patent portfolio with high RTA does not necessarily have high PS.

### 2.2.3. Technology class analysis

Patent documents refer to International Patent Classification (IPC) as

technological classes. IPC was originally meant to ease search work during examination,<sup>9</sup> which is why an examiner assigns IPC codes to a patent application during examination and any time afterwards. As in the citation analysis, special care must be taken when using technology class analysis, for three main reasons. Firstly, IPC versions change from time to time. Thus, one must ensure that IPC codes are defined under the IPC version, or that different IPC codes from different IPC versions are in the same technological class. Secondly, on some occasions, IPCs are not correctly assigned. For example, a patent application whose title includes “processing” may be erroneously assigned under A22C (“processing” meat, poultry, or fish) and G06F (Electric digital data “processing”) in IPC version 2013. Similar mistakes are observed in various technological fields. However, since most patents are assigned to more than one IPC code, the issue is less difficult. Thirdly, IPC becomes problematic when an invention is a newly defined technology. By nature of the IPC-assigning process, examiners cannot assign IPC codes to a patent application whose invention(s) is new.

Despite the limits of technology classifications, two patent statistics are useful for analysis. Trajtenberg et al. (1997) defined generality as how subsequent inventions spread across different technological fields and originality as how back-up inventions spread across different technological fields. If generality/originality is large, the technical advances/roots of the originating invention are broad rather than concentrated in a few, respectively. The Herfindahl Index describes the calculations of generality and originality as follows:

$$Gen = 1 - \sum_{k=1}^{N_g} \left( \frac{N_{citing}(k)}{N_{Citing}} \right)^2$$

$$Org = 1 - \sum_{k=1}^{N_o} \left( \frac{N_{cited}(k)}{N_{Cited}} \right)^2$$

---

<sup>9</sup> International Patent Classification (Version 2013) 6: *The Classification, being a means for obtaining an internationally uniform classification of patent documents, has as its primary purpose the establishment of an effective search tool for the retrieval of patent documents by intellectual property offices and other users, in order to establish the novelty and evaluate the inventive step or non-obviousness (including the assessment of technical advance and useful results or utility) of technical disclosures in patent applications.*

where  $k$ ,  $N_g$ ,  $N_{citing}$ ,  $N_o$ , and  $N_{cited}$  are the patent class index, the number of different classes to which the citing patents belong, the number of citing patents, the number of different classes to which the cited patents belong, and the number of cited patents, respectively. For example, generality and originality in Figure 2.2 is 0.5 and 0.66, respectively. An alternative way to calculate generality and originality is to count the number of IPC codes in the citing and cited patents (Gambardella et al., 2007).

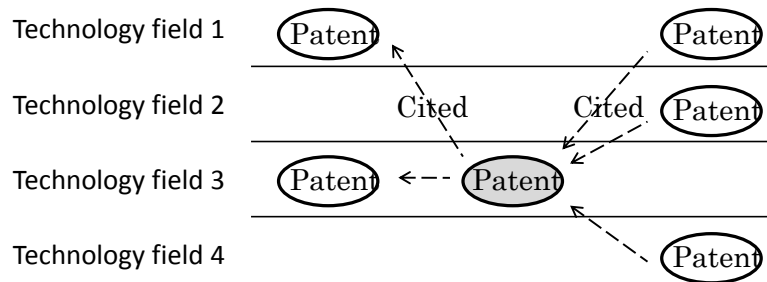

Figure 2.2 Example of Generality and Originality

#### 2.2.4. Inventor analysis

Patent documents also provide ‘inventor information’. Firstly, the number of inventors has been found to correlate positively with the endogenous quality of their inventions. Wuchty et al. (2007) found that the number of authors in papers has increased in recent papers, which tend to have more citations than those worked on by one author. This implies that, thanks to the increased number of authors, different knowledge can be combined and developed. Jones (2009) also found that many inventors in a team diversified knowledge and helped create high quality inventions. Thus it is clear that the more inventors in an inventing process, the greater the chance that inventors exchange ideas.

The inventor information can also be used as a proxy of absorptive capacity, which is defined by Cohen et al., (1990) as the “ability to recognize the value of new information, assimilate it, and apply it to commercial ends.” Absorptive capacity is regarded as a primary requirement to utilize external knowledge. Since the ability to recognize, assimilate, and apply new information is mostly up to individuals in a firm or country, many studies have used human capital as a proxy of absorptive capability. Examples are the investments in training scientists and engineers (Mowery et al., 1995), the number of scientists and engineers in R&D (Keller, 1996), R&D departments whose staff have a doctorate degree (Veugelers, 1997), and the ratio of scientists and researchers

to total employees (Escribano et al., 2009).

In addition, the inventor information in patent documents is useful for identifying specific inventors such as high performing engineers. These can be found by counting the number of patent applications per inventor. From the analysis of the number of patents per U.S. and Japanese inventors in semiconductor firms, a small number of inventors accounted for a significant proportion of total patent applications (Narin et al., 1995). In fact, three highly productive inventors patented 42% of the patent data in a study for the author's client. A similar trend was observed in the chemical, electrical, and mechanical industries in Germany (Ernst et al., 2000). Another example is identifying specific inventors in each patent by their names together with their addresses, which enables us to track if inventors moved to a different work place and changed their affiliations. This methodology is applied in a study by Dokko et al. (2010) that used inventors' information to track mobility between firms.

## **2.3. Research data**

### **2.3.1. Patent database**

In this study, European Patent Office (EPO) Worldwide Patent Statistical Database (PATSTAT) is used. There have been efforts to construct huge and reliable patent databases by organizations and patent offices such as: National Bureau of Economic Research (NBER) patent database in the United States (Jaffe et al., 2002), EPO PATSTAT in Europe, Institute of Intellectual Property (IIP) patent database in Japan (Goto et al., 2007), and OECD patent database. Other patent offices in China (State Intellectual Property Office) and India (the Office of the Controller General of Patents, Designs & Trade Marks) also tried to construct nation-wide patent databases. From the comparison among NBER patent databases, PATSTAT and IIP patent database (Nagaoka et al., 2010), and especially PATSTAT offer more information than other patent offices. For example, PATSTAT provides information about priority patents, unlike NBER and IIP patent databases. EPO PATSTAT is made up of reports from more than 100 countries. The data, which include 60 million patent applications and 30 million granted patents, are updated every six months. The EPO PATSTAT diagram in Figure 2.3 shows the information relating to patent application in TLS201\_APPLN, and for published patent documents in TLS211\_PAT\_PUBLN. Patent family information is in TLS204\_APPLN\_PRIOR, TLS218\_DOCDB\_FAM, and TLS219\_INPADOC\_FAM.

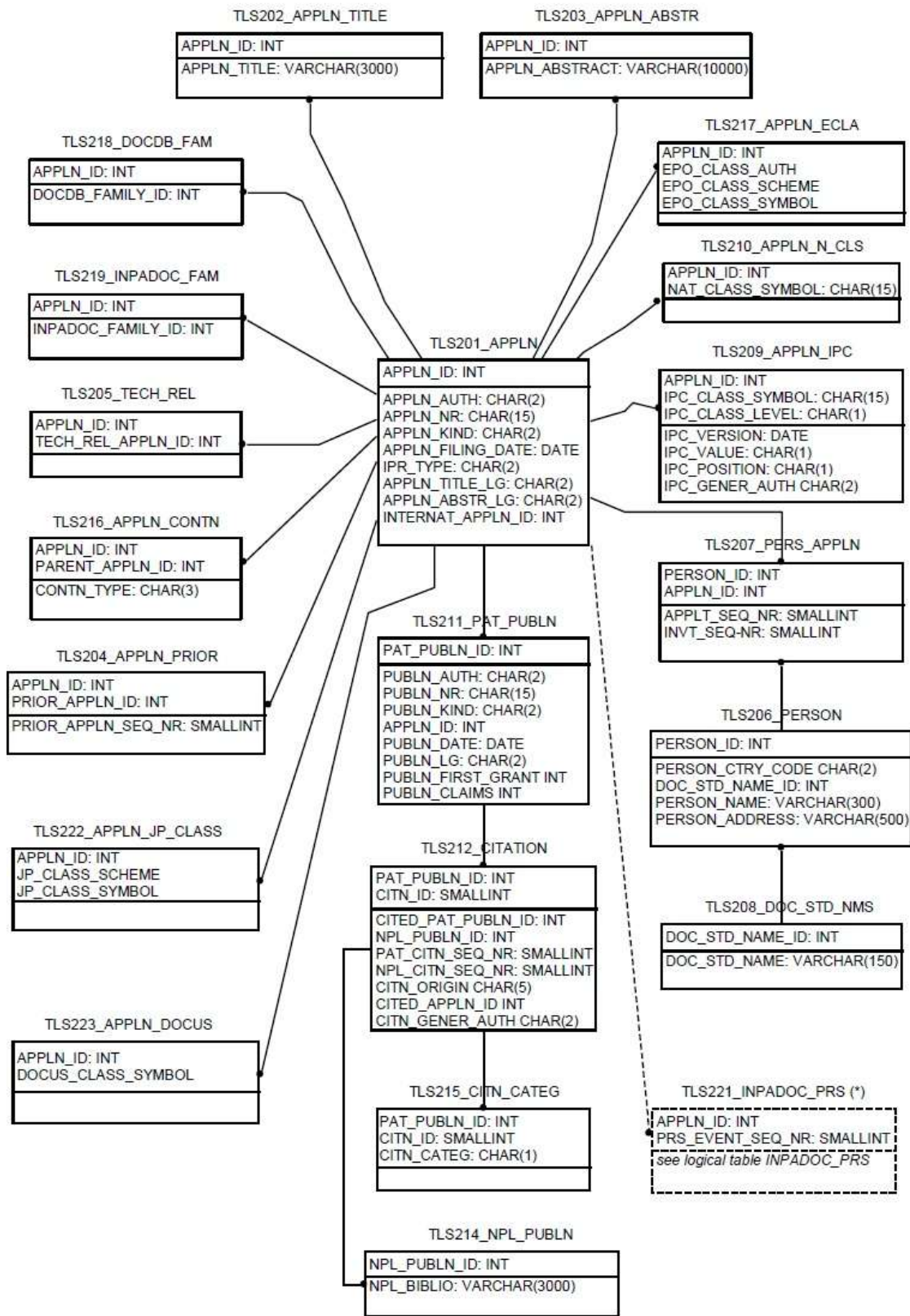

Figure 2.3 EPO PATSTAT Diagram



On some occasions such as for counting the number of patents assigned to a firm, the Derwent Innovation Index (DII) is used in this study because of its ease to search. DII, which covers over 14.3 million patents from 40 countries<sup>10</sup> is a patent database provided by Thomson Reuters and is made up of Derwent World Patent Index and Derwent Patent Citation Index.

Although processed/cleaned patent databases exist, I prefer to use EPO PATSTAT raw data. Processed data are easy to use, however, the degree of freedom is limited by the database developers for various reasons. They do not always provide the algorithms that are used to clean the data. Thus, it is difficult to test if the database construction is adequate. Once the full description of the algorithms is available, it is easy to reproduce the same database from the raw data and therefore not necessary to use processed databases. Furthermore, compatibility between different processed databases is not always supported by the developers. Since each processed database is specific, depending on its purpose, sometimes common information is limited. And, since new IDs are usually allocated when processing the raw data, it is hard to match identical data from the differently processed databases. It is also hard to remodel the processed databases. For example, OECD Harmonized Applicants' Names (HAN) database provides a dictionary of applicants' names. However, users have to do additional work if they want to remodel the database according to parent and subsidiary companies. There are additional issues such as the frequency of database update. Thus for all the above reasons, EPO PATSTAT, which provides the maximum degree of freedom, is preferable.

### 2.3.2. Essential patents database

A list of essential patents was retrieved from two essential patent databases. The first database is European Telecommunications Standards Institute (ETSI) Special Report (SR) 000314. This database's construction is based on declaring essential patent owners. ETSI SR 000314 provides comprehensive information including patent application number, patent publication number, patent title, patent office, declaring company, IPR declaration date, and projects to which the essential IPRs belong (Figure 2.4).

---

<sup>10</sup> [http://wokinfo.com/products\\_tools/multidisciplinary/dii/](http://wokinfo.com/products_tools/multidisciplinary/dii/) (last accessed May 2, 2013)

	A	B	C	D	E	F	G	H	I	J	K
	Company name	Project	Patent title	Country of registration	Application No.	Publication No.	Countries applicable to App./Publication	Work Item or ETSI Deliverable No. with Section and Version	Declaration date to ETSI	Notes	Other Patents in country
4	AT&T	GSM	Digital Speech Encoder	CANADA		1,181,854			1995/10/3	AT&T have stated that all of the identified patents have corresponding foreign	
5	AT&T	GSM	Digital Speech Encoder	FRANCE		8,219,772	FRANCE		1995/10/3	AT&T have stated that all of the identified patents have corresponding foreign	
6	AT&T	GSM	Digital Speech Encoder	GERMANY		3,244,476	GERMANY		1995/10/3	AT&T have stated that all of the identified patents have corresponding foreign	
7	AT&T	GSM	Digital Speech Encoder	UNITED KINGDOM		2,110,905	UNITED KINGDOM		1995/10/3	AT&T have stated that all of the identified patents have corresponding foreign	
8	AT&T	GSM	Digital Speech Encoder	JAPAN		1,332,758	JAPAN		1995/10/3	AT&T have stated that all of the identified patents have corresponding foreign	
9	AT&T	GSM	Digital Speech Encoder	SWEDEN		Published 456 616	SWEDEN		1995/10/3	AT&T have stated that all of the identified patents have corresponding foreign	

Figure 2.4 Snapshot of ETSI SR 000314.

Efforts have been made to construct an essential patents database, Open Essential IPR Disclosure Database (OEIDD) by researchers (Bekkers et al., 2012b). They retrieved (declared) essential patents from several well-known standardization bodies and OEIDD now contains over 40,000 essential patents. One of the drawbacks of using original essential patent reports is that they contain errors and are not updated with changes in ownership and other information. However, the researchers corrected errors and reflected the changes in OEIDD, which provides other data such as firms' business models, home region, etc.

### 2.3.3. 3GPP Meeting minutes

This study also uses 3GPP's minutes of meetings. 3GPP publishes its documents on its server<sup>11</sup> and 3GPP Technical Specifications are on its website. 3GPP makes the technical contributions and meeting minutes like the documents recording standardization processes available to the public. A list of each meeting's participants with their contacts and affiliations can be found in the meeting minutes. In this study, all the participants were retrieved from the minutes and matched with inventors in the patent database.

<sup>11</sup> <ftp://ftp.3gpp.org/>

Considerable efforts were made to match the meeting attendees' names to the inventors' names in the patent database. Firstly, patent data were retrieved 'roughly'<sup>12</sup> by matching the meeting participants' names with inventors' names. Secondly, the meeting participants' affiliations were matched with the inventors' assignees in the patent database. Thirdly, entries were manually checked one by one to confirm whether the data were correct, then patents found to be incorrect were excluded. This manual matching was used to acquire the inventors' IDs in the patent database. Finally, the patent data were removed using the inventors' IDs to prevent errors in cases where patents were invented by attendees, but the assignee information was missing. However, different inventors' names still appeared to be duplicated in the same company name, especially in large companies. The international patent classification (IPC) was used for this study. I removed IPCs with essential patents and filtered out patents which do not belong to the essential patents' IPCs.

---

<sup>12</sup> In the meeting minutes, one inventor wrote their name in a different format: [First name] [Second name] [Family name], [First name] [Abbreviation of Second name] [Family name], [Abbreviation of First name] [Family name], [Family name] [First name], etc. I used all the possible pairs to find inventors in the patent database.

## Chapter 3: Determinants of Essential Intellectual Property Rights for Wireless Communications Standards: Manufacturing firms vs. non-practicing entities<sup>13</sup>

### 3.1. Introduction

Standardization is known to have both positive and negative effects (Tassey, 2000). It facilitates the development of a commonly accepted system, thereby achieving compatibility with complementary systems. At the same time, however, it reduces the variety of choices. When a standard is necessary in business, each company is required to properly and strategically harmonize the contradictory effects: that is, provide differentiated and specialized products while ensuring compatibility with other products. Standardization is especially beneficial for the network industry, where the interconnection of different products and system components is required for reliable services with de-jure standards such as a Global System for Mobile communications (GSM) and a Universal Mobile Telecommunications System (UMTS) in the wireless communications industry.

Once a standard is completed, the related technologies protected by patents become essential intellectual property rights (IPRs). The essential IPR concept is well defined by the European Telecommunications Standards Institute (ETSI) (2013).

**"ESSENTIAL"** as applied to IPR means that it is not possible on technical (but not commercial) grounds, taking into account normal technical practice and the state of the art generally available at the time of standardization, to make, sell, lease, otherwise dispose of, repair, use or operate EQUIPMENT or METHODS which comply with a STANDARD without infringing that IPR. For the avoidance of doubt

---

<sup>13</sup> This chapter is also appeared in: Byeongwoo Kang, and Kazuyuki Motohashi, "Determinants of Essential Intellectual Property Rights for Wireless Communication Standard: Manufacturing firms v.s. non-manufacturing patentees," RIETI Discussion Paper Series12-E-042, 2012/06.

in exceptional cases where a STANDARD can only be implemented by technical solutions, all of which are infringements of IPRs, all such IPRs shall be considered ESSENTIAL.

"IPR" shall mean any intellectual property right conferred by statute law including applications therefor other than trademarks. For the avoidance of doubt rights relating to get-up, confidential information, trade secrets or the like are excluded from the definition of IPR.

Thus, essential IPRs mean those without which a standardized system cannot operate. Therefore, owners of essential IPRs can take advantage of the relevant patents in their business strategies. First, essential IPRs are important for entering a market. Essential IPRs correlate positively with market power (Bekkers et al., 2002). For example, Motorola conducted exclusive cross-licensing with other parties in the GSM market, selecting only parties with valuable IPRs for Motorola. Consequently, it dominated the market. Second, owners of essential IPRs can demand royalties from use of the patents reflected in the standard. For example, although Qualcomm has a business of chipset developments such as Snapdragon, its royalties represent a considerable portion of its revenue (Mock, 2005).

The novelties of this paper are twofold. A novelty of this paper is to investigate R&D management in standardization. This paper shows the difference in the R&D in standardization between NPEs and manufacturers. Standardization is a process to set a standard. The standardization proceeds with collaboration between collaborators and competitors in a market. Collaboration between competitors is a key requisite for successful technological innovation because resource and competence are dispersed organizationally and geographically (Teece, 1992). In fact, R&D collaboration has been increasing for last decades (Hagedoorn, 2002; Gnyawali et al., 2011). By effectively collecting and combining the resource and competence, the technological innovation can be accelerated. However, as I observe in the analysis, NPEs' contribution to the technology standard per se is limited; (1) NPEs' technological contribution to standardization is lower than manufacturers, and (2) NPE's technological contribution is not from new knowledge but from existing standard. Even if it is natural to assume that non-manufacturers are more flexible than manufactures as they are less constrained in the exploration of the technological space for any occasion, a better understanding is necessary to not provide injudicious policy. Another novelty of this

paper is that this paper is the first study which sheds light on inventors' role in standardization. This study provides evidence of the complementarity between standardization and invention activities, by observing these activities at the inventor level. One study tries to explain the relationship between inventors' patenting and participation in standardization. Gandal et al. (2006) found that inventors' patenting can be predicted by their participation in standardization, not the other way around. However, they could not explain why. This study is the first study to explain a reason by focusing on the inventors' involvement in standardization.

The structure of this paper is as follows. First, Section 3.2 provides prior literatures on determinants in obtaining essential IPRs in wireless communications standards. Then, I discuss the standard setting process in detail. In Section 3.3, I formulate hypotheses. Section 3.4 describes the data set used for this analysis. In Section 3.5, I discuss our analysis results and verify the hypotheses formulated in Section 3.4. Section 3.6 concludes with remarks on the future research agenda and policy implications.

### **3.2. Literature review**

Studies have identified certain key determinants in obtaining essential IPRs in wireless communications standards. The first determinant is technological advancement (Rysman et al., 2008; Layne-Farrar, 2011; Bekkers et al., 2011). For decades, forward citations have served as a proxy for technological impact (Carpenter et al., 1981; Karki et al., 1997). The interpretation of forward citation is that the more a patent is cited by follow-up patents, the more technologically important it is.<sup>14</sup> Although Rysman, Layne-Farrar, and Bekkers used different data sets, they drew the same conclusion by analyzing forward citations of the given data set. Second, firm-level strategic involvement is important for standardization. Focusing on external alliances among the 3rd Generation Partnership Project (3GPP) members, Leiponen (2008) concluded that firms' external cooperative activities with standard setting organizations (SSOs) and active participation as a core member of technical committees are important for the

---

<sup>14</sup> However, the use of forward citations as an indicator of technological quality in a patent, though widely adopted, is not without limitations. The discussion is explained in Section 3.4.1.

standard-setting outcome. Bekkers et al. (2011) also verified the importance of firms' strategic involvement in the standardization process by analyzing the number of participating work items in one company and voting weights in the standardization process. Third, patent filing behavior has been shown to determine whether a patent becomes essential. Berger et al. (2012) showed that essential IPRs contain more claims and more frequent amendments than do those that are not targeted for standardization. In addition, Berger determined that essential IPRs have longer pendency than have other patents. The fourth determinant is that SSOs' members adopt different strategies for standard setting because they have different histories and policies and these differences influence their capabilities (Leiponen, 2006).

Many prior studies (Leiponen, 2006; Leiponen, 2008; Bekkers et al., 2011; Berger et al.; 2012) highlighted non-R&D factors in the standardization. But, standardization is a process to set a standard that can be a base to stimulate further innovation in an industry. In wireless communications industry, the standardization has been to set a technological base to connect. Therefore, this study investigates the standardization in R&D management point of view. I consider obtaining essential IPRs as a proxy of R&D process in standardization, and conduct analyses based on factors for R&D management; core competency, knowledge flow, and inventors' involvement into the standardization.

### **3.3. Hypotheses**

The first hypothesis relates to core competencies (Prahalad et al., 1990). Because firms have different business markets, resources, histories, and research policies, they accrue different knowledge and expertise from different R&D and business experiences. Consequently, all firms obtain their core technological competencies in different technological fields. During standardization, firms with different core technological competencies develop a commonly accepted system by adopting technological proposals from each firm. However, these proposals sometimes conflict with each other because owing to their different core technological competencies, each firm wants to develop a standardized system favorable to its core technological competencies. If some standardization meeting members lack the required technology or expertise to develop a standard when that standard is successfully completed, those members must invest in new resources to

obtain the required technology and know-how. However, the investment's success is not always guaranteed. From this situation, I derive the first hypothesis as follows:

**Hypothesis 1.** Member firms obtain essential IPRs on the basis of their core technological competencies.

However, the wireless communications industry comprises manufacturers and NPEs. Manufacturers participate in the standardization process because they need a standardized system as a basis upon which to develop and market their products. By accumulating experience in product developments and tests, manufacturers can develop specific technological strengths. In contrast, NPEs' business model is to make profit from royalties, and so they derive value from holding economically important patents regardless of the product-market type. Therefore, it is less important for NPEs to accumulate a patent portfolio in a specific technological field than to conduct R&D in mainstream areas of the standardization development process. Consequently, I further develop Hypothesis 1 as follows:

**Hypothesis 1-1.** The behavior described in Hypothesis 1 is more probable for manufacturers than NPEs.

While testing this hypothesis, I need to numerically measure core technological competency. Many measurement methodologies have previously been proposed, and I use Revealed Technology Advance (RTA) and Patent Share (PS) (Patel and Pavitt, 1997). The RTA is the shares of the firm in total patenting in each technological field divided by the firm's aggregate share in all the fields. A technological field with high RTA is understood as highly important within a firm. In contrast, PS is the shares of a firm's total patenting in each technological field. A technological field with high PS is thus understood as highly important compared to other firms' patents in the same technological fields.

The second hypothesis relates to technology strategy. In the wireless communications industry, innovation occurs cumulatively, that is, the following companies enter the wireless communications market on the basis of the technology they learn (or must adopt) from the leading company's patents. For example, He et al. (2006) analyzed the backward citations among Ericsson,



Motorola, Nokia, and Samsung Electronics. They found that there was knowledge flow from Motorola to others in the 1980s when Motorola was a dominant player in the market; however, the number of citations of Motorola's patents decreased in the 2000s when Nokia was a dominant player in the market. The authors concluded that the knowledge flow from Motorola to others was the key factor in others' entering the market and catching up. As knowledge flow is important for market entry, I will test the importance of knowledge acquisition in the standardization process as well.

**Hypothesis 2.** Knowledge flow is important in obtaining essential IPRs.

By using backward citations to measure learning, I categorize patents in two perspectives: Self/Non-self backward citations and the number of essential IPRs in the backward citations. First, I consider the knowledge flow from essential IPRs. As previously mentioned, wireless communications technologies in a standardized system have complex interrelations. The standardized system is updated as a result of unexpected technological problems or the need for new functions. When a company has a technology proposal, the proposal must be well connected to the previous version of the standard (i.e., past essential IPRs). Therefore, knowledge of past essential IPRs is expected. Second, I consider the technology strategy, that is, whether the subsequent innovation is based on its own technology or that of others. Here I predict that manufacturers and MNPs apply different strategies. As hypothesized previously, manufacturers are assumed to have greater incentives to create a patent portfolio in a specific technology area. Because their revenue model is based on product sales, even the non-essential IPRs that are related to essential IPRs are important. Therefore, it is likely that their technology strategy is to develop subsequent innovations based on their own technologies and also on both essential and non-essential IPRs. In contrast, NPEs may have greater incentive to maintain their dominant position in the standardization process and develop their technological capabilities in mainstream areas of technology standardization. Therefore, their strategy is to develop subsequent innovations based on essential IPRs, regardless of whether these are their own patents. Therefore, I have the following hypotheses about technology strategy.

**Hypothesis 2-1.** Both NPEs and manufacturers develop subsequent innovations

based on essential patents.

**Hypothesis 2-2.** Manufacturers develop their subsequent innovations based on their own technologies, i.e. Manufacturers relies on internal knowledge than knowledge flow from external entities.

**Hypothesis 2-3.** NPEs develop their subsequent innovations based on essential patents, regardless of ownership.

The final hypothesis is related to inventors who attend standardization meetings. The workflow of standardization can be understood as a repeating cycle consisting of three phases: preparing for the up-coming standardization meeting, participating in the meetings, and the interval between two meetings (Figure 3.1).

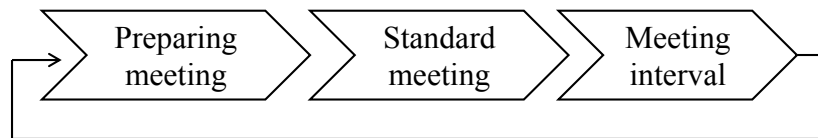

Figure 3.1. The workflow of standardization

The tasks required in the first phase (preparing for the meeting) include developing strategies for the next meeting and making contributions (a type of report including technical proposals and discussions). The second phase is the standardization meeting. Attendees from various companies/organizations gather at one place for discussions. The final period—the meeting interval—is when planners develop the agenda for the next standardization meeting and conduct private discussions with other companies and organizations such as e-mails, teleconferences, and other media or by personal visits.

Thus, an attendee becomes the center of discussions and negotiations in the standardization. Discussions with other parties provide the attendees with hints of what will appear in the next standardization process; therefore, they can invent whatever is likely to be required in the standard and bargain their inventions in the standardization meetings. Further, by being the center of discussions between his own affiliation and other affiliations, an attendee is required to involve his colleagues in the invention process. Our third hypothesis compares attendees and non-attendees.

**Hypothesis 3.** Inventors who attend the standards meeting will more likely to

invent a new essential IPR than will non-attendees.

Here, I further develop the discussion about attendees. The first factor considered is whether a patent is invented when its inventor was a meeting attendee. The standardization meetings have several attendees, and their experiences vary. For example, some people may have attended the meetings since the early 2000s, whereas others may have started attending only in the more recent 2000s. Some attendees participate a few times only for some months, while others participate often and for years. I argue that a patent invented by those “attending the standard meetings” has greater probability of being essential than has the patent invented by those “not attending”. Invention activity may begin before an inventor first attends a standard meeting and may continue even after the inventor stops attending meetings. However, attendees are apt to become the center of discussions and negotiations. Among all the patents sought by an inventor, those sought when the inventor is a meeting attendee reflects the technological needs derived from technological discussions and strategic negotiations. This discussion leads to our in-depth hypothesis as follows.

**Hypothesis 3-1.** Among all the patents sought by an inventor, those applied for when the inventor attends a meeting have greater likelihood of becoming essential.

Wireless communications includes various technological issues (Goldsmith, 2005; Dalman et al., 2008) such as wireless channels, signal modulations, coding, multiple antenna transmissions, multiple frequency carriers, transmission power, and bandwidth. Although those technologies seem independent of each other from an academic viewpoint, they inter-relate in a complex manner when a system is being designed. Sometimes, proposed schemes in the standardization meetings have contradictory functions. In such cases, attendees must identify technological issues when developing the standard, discuss them from various technological aspects, and resolve them together through a consensus. Therefore, inventors developing a wireless standard require deep understanding of different technological issues.

Given this process that requires a consensus, an attendee may want to prepare various solutions to a given technological issue. The development of a standard is a complex process of discussions and negotiations. If an attendee

prepares only one solution to a technological issue, he might face difficulty in obtaining agreement because of other attendees' personal preferences for technology, operational conflicts with others' proposals, and similar issues. However, if various solutions to a technological issue are prepared, the inventor can flexibly discuss them with other attendees to reach agreement. In this study, the number of inventions within one year before the date when the originating patent was applied for is used as a proxy of the proposals that the inventor can suggest as solutions to a technological issue. Bekkers et al. found that the average delay between the patent application and essential IPR declaration to ETSI has been decreasing (Bekkers et al., 2011). In 2002, the average delay was 2.19 years. I reviewed recent standards meeting minutes of 3GPP (<ftp://ftp.3gpp.org/>), and confirmed that the discussion agenda changes in every meeting, and as a result few issues are discussed over the course of a year. Therefore, I use the number of inventions within one year before the date when the originating patent is applied. The hypotheses derived from this discussion are as follows.

**Hypothesis 3-2.** An inventor requires wider technological understanding to obtain an essential IPR.

**Hypothesis 3-3.** The more solutions an inventor can suggest for a technological issue, the greater probability he has of obtaining an essential IPR.

For Hypothesis 3-2, I use generality (Trajtenberg, et al., 1997) as a proxy of an inventor's breadth of technological understanding. The authors defined generality as how the follow-up technical inventions spread across different technical fields. If the generality is large, the technical advances from the originating invention are broad and the original invention covers different technological issues. In this study, the average generality of all inventions from an inventor serves as a proxy of the inventor's breadth of technological understanding. For Hypothesis 3-3, I use the number of inventions within one year before the date when the originating patent was invented as a proxy of the number of solutions that one meeting attendee can propose.

Designing a system is a type of invention. Many inventions in various categories are necessary for a system to operate. Inventors must identify conflicting functions and properly redefine them when developing a system. In this context, a patent is a proxy for technological activities. Patent application for an invention

serves to verify the invention's novelty and utility in the US patent law (the industrial applicability in European patent law). If an inventor has applied for more patents than have others, that inventor is considered to have greater ability and expertise to invent useful things. Similarly, a standards meeting attendee with more patent applications is believed to have greater ability and knowledge for developing a wireless communications system. As a person's ability increases with his experience as an inventor, I assume that the attendee's ability and knowledge as an inventor (i.e., a system developer) increases with his inventing experience. I focus on the counting number of patent inventions before the originating patent application that becomes an essential IPR. By using this number as a proxy for an attendee's experience as an inventor, I test whether invention experience affects the attendee's probability of obtaining an essential IPR designation. Consequently, the fourth hypothesis to test in this study is as follows.

**Hypothesis 3-4.** An attendee with more invention experience has a greater probability of obtaining essential IPRs.

### 3.4. Data

To quantitatively test our hypotheses, I use reports from the ETSI, 3GPP, and the European Patent Office (EPO) Worldwide Patent Statistical Database (PATSTAT). I use the ETSI data for several reasons, the most important and critical reason being that ETSI has constructed a very large and publicly available database for essential IPRs and their policies (ETSI, 2012). Because there are many standard projects and as a result the corresponding patents are numerous, I narrow the project to only Wideband Code Division Multiple Access (WCDMA) patents.

#### 3.4.1. Patent dataset

To test our hypotheses, this study uses patent data. As will be discussed, this study derives indicators from patent citations. However, they are not without limitations. A patent citation analysis is conducted mostly for two reasons: (1) to measure technological value, (2) to measure knowledge flow, also called knowledge flow. However, concerns are raised because of the fact that most citations are added by examiners rather than applicants and/or inventors (Alcarcer et al., 2006; Criscuolo et al., 2008; Alcarcer et al., 2009). The concerns are not applicable in

measuring the technological value in a patent by counting forward citations. Patent examiners determine the patentability of a patent application by finding relevant prior arts. Even if the number of forward citations of a patent document is increased mostly by patent examiners, the increase of the forward citations must be interpreted as the examiners for themselves reach to the technologically valuable inventions. Thus, the number of forward citations represents the endogenous technological value in a patent whether the forward citations are increased by examiners or by applicants and inventors. However, as a matter of fact, patents crucial for technological development in terms of a technological trajectory didn't receive many citations (Fontana et al., 2009; Martinelli, 2011). One possible explanation is that technologically valuable inventions are not always successfully commercialized. Meanwhile, the concerns are applicable in measuring knowledge flow although patent citation analyses are widely used to measure knowledge flow (Verspagen, 2007). However, since examiners are not involved in invention process, knowledge flow from, to, or between examiners are not in interest. In this sense, if most citations are added by examiners rather than applicants and/or inventors, there is a concern that knowledge flow cannot be properly measured. However, I must understand there is also a risk for applicants and inventors to add citations in a patent document. Even if the applicants and the inventors are legally required to provide knowledge that affected their inventions (duty of candour) in some patent office, they disclose those citations that support, not block, the claims in the patent document (Hedge et al., 2008). On the other hand, examiners find prior arts that block the claims. Nevertheless, as Fontana et al. (2009) and Martinelli (2011) also highlighted the effectiveness of patent citations to measure knowledge flows in their papers, I use the patent citations as representing knowledge flow.

I collect patent data from EPO's PATSTAT. First, I limit the patent data applied to the US Patent and Trademark Office (US PTO) because of significance of the US market. Patent applications are subject to a tradeoff between dominance and cost. Because of the US market's global significance, companies doing business in global markets apply for patents in the US, taking the risk of high cost. I further narrow the dataset by application years. According to Bekkers et al. (2011), the oldest essential IPRs were applied for in 1979; therefore, I extract the patent dataset of applications beginning in 1979. Further, the most recent application year available in the version of our patent database is 2009; hence, our dataset contains those patents applied for between 1979 and 2009.

To extract patents relevant to standardization, the dataset is further filtered by the international patent classification (IPC). The WCDMA consists of three parts: air interface, radio access network, and core network. I focus on air interface because it has the greatest portion of patents (Goodman and Myers, 2005). I filter our dataset using the following IPCs related to air interface: H1Q, H03M, H04B, H04H, H04J, H04K, H04L, H04N 01<sup>15</sup>, H04Q, and H04W. By using these IPCs, I can narrow the dataset to only air interface-related technologies. I confirmed that nearly 95% of essential IPRs in the WCDMA are in these categories. This method has been verified by Bekkers and West (2009), whose study uses nearly the same IPCs. The difference is that I further narrow our IPCs down only to air interface-related technologies.

Finally, I use only four companies among the 3GPP members.<sup>16</sup> The main reason that I use these four companies is the portion of essential IPRs owned by those companies in our patent dataset. Details will be explained in Section 3.4.2. Matching the inventors and the meeting participants is not an easy work. So, I narrow down four firms that own 70% of all essential IPRs in WCDMA. The patent searching conditions are summarized in Table 3.1.

Table 3.1. Patent searching conditions

Patent Database	EPO PATSTAT (Ver. September 2010)
Patent Office	US PTO
Application Years	1979–2009
IPC	H1Q, H03M, H04B, H04H, H04J, H04K, H04L, H04N 01, H04Q, H04W
Company	InterDigital, Nokia, Qualcomm, Samsung Electronics,

Through the criteria described in Table 3.1, I obtained 30,334 patent

---

<sup>15</sup> I add a main group (01- Scanning, transmission or reproduction of documents or the like, e.g. facsimile transmission-) in H04N. Since H04N is about inventions for Television, most inventions are probably aimed at Television. So, I presume that the data may be skewed because one of Samsung Electronics's main business is in Television market. However, transmission technologies aimed at Television can be applicable for mobile communications. Therefore, I use H04N 01 rather than H04N.

<sup>16</sup> A compact business history of each of the four companies is described in Appendix A.

applications. The number applications owned by each company is shown in Figure 3.2. Among these, Samsung Electronics holds the highest number of patent applications (10,571). One reason for this result is that the IPCs used in this study include other wireless communications in addition to cellular systems, such as television. As a consumer electronics company, Samsung Electronics has a broad business area that includes the television market. InterDigital holds the smallest number of patent applications (3,193), which is less than one third of Samsung Electronics' applications. Although it has the smallest number of patent applications, InterDigital is one of the largest essential IPR holders. Their efficiency in obtaining essential IPRs (= the number of essential IPRs/the number of patent applications) is very high. Although the numeric values differ, I find a tendency similar to the analysis shown in Bekkers and West (2009).

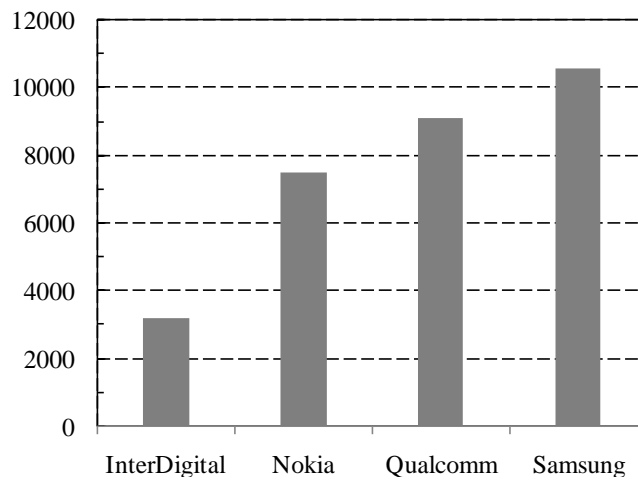

Figure 3.2. The number of patent applications by the four companies

Figure 3.3 depicts the four companies' numbers of annual patent applications to the US PTO. Although I took the patent dataset from 1979, the applications of the four companies started in 1988. The reason I identified patent applications from 1979 was a prior study (Bekkers et al., 2011) found that the oldest essential IPRs were applied in 1979. In their work, they used 1850 firms for analysis, 50 of which own essential IPRs. Meanwhile, I selected four companies, Ericsson, Nokia, Qualcomm, and Samsung Electronics, which own most essential IPRs due to the amount of works to identify the inventors in interest as will be discussed in Section 3.4.3. Accordingly, none of Ericsson, Nokia, Qualcomm, and Samsung Electronics was the applicant of the first essential IPR introduced by



Bekkers et al. (2011). Nokia and Samsung Electronics show a similar tendency: their peak of patent applications is in 2004 and 2005, after it decreases. However, Qualcomm's patent applications continuously increase through 2009. Compared to Nokia and Samsung Electronics, Qualcomm's applications significantly increase beginning in 2004. InterDigital's patent applications fall slightly in 2009 but gradually increase thereafter. One explanation for InterDigital's and Qualcomm's increase and Nokia's and Samsung Electronics' decrease is our using patent applications to the US PTO. Nokia and Samsung Electronics are Finland- and Korea-based companies, respectively, whereas both InterDigital and Qualcomm are US-based. InterDigital's and Qualcomm's patent applications to the US PTO are domestic, but Nokia's and Samsung Electronics patent applications to the US PTO are foreign. Therefore, there might be uncounted patent applications to the US PTO for Nokia and Samsung Electronics which were applied to in their home country's PTO as the first patent application and therefore not listed in the US PTO. A second explanation for the result seen in Figure 3.3 relates to the Qualcomm and InterDigital business models. In Qualcomm's success in business, code division multiple access (CDMA)-based technology was very important (Mock, 2005). In wideband CDMA (WCDMA), 15.4% of IPRs essential to WCDMA are CDMA-based technologies (Goodman and Myers, 2005; Lakoff, 2008). Even now, when Qualcomm is developing chipsets, its main revenue comes from royalties. InterDigital's business model is also to hold essential IPRs in the standard and license those to other companies without manufacturing any products. This Figure supports the idea that success in standardization is crucial for Qualcomm and InterDigital. This fact is further supported when compared to the numbers of essential IPRs and patent applications in Section 3.4.2. In addition, there are unexpected results. One is that between 2003 and 2007, Samsung Electronics applied for many more patents than did the other three companies. The other surprising result is that Nokia's patenting activity has decreased markedly since 2004. Nokia's patent applications in 2009 are roughly a quarter of its 2004 patent applications. These findings merit further analysis, but that analysis exceeds the scope in this study.

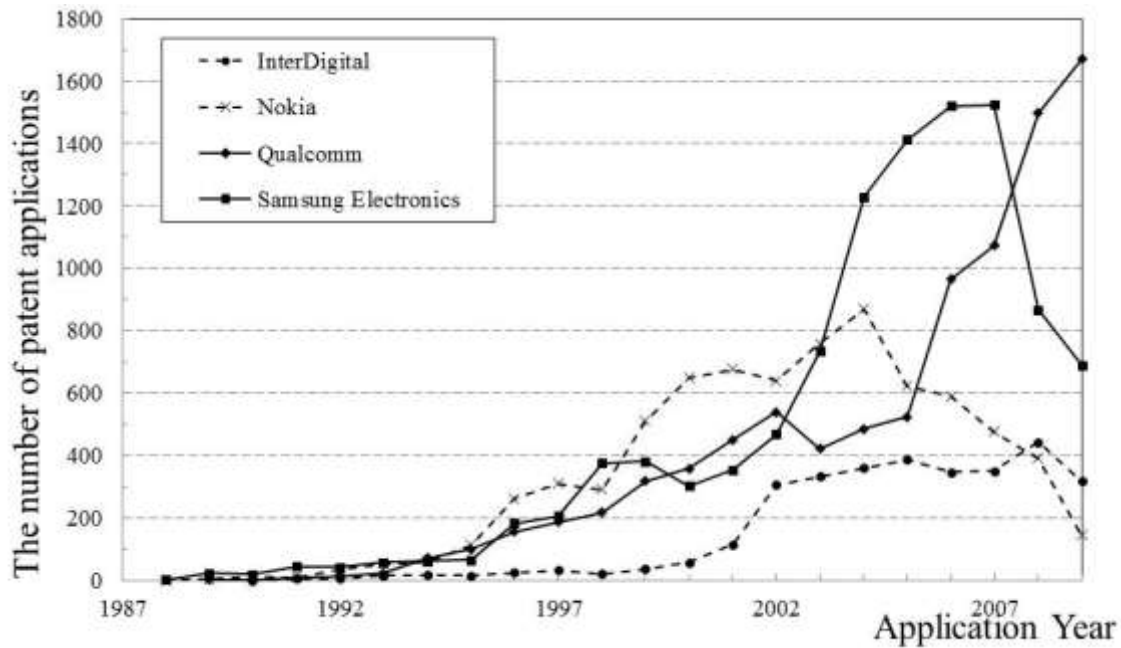

Figure 3.3. The number of annual patent applications

#### 3.4.2. Essential IPR

ETSI has defined its IPR policy, and it requires its members to inform it of their essential IPRs (ETSI, 2012). Twice a year, ETSI updates and reports the list of (disclosed) essential IPRs in the ETSI Special Report 000314 (ETSI, 2011). ETSI SR 000314 provides information that includes patent application number, patent publication number, patent title, patent office, declaring company, IPR declaration date, and projects to which the essential IPRs belong. I identify essential IPRs in our dataset by matching US publication numbers to those reported to ETSI. Figure 3.4 depicts the WCDMA essential IPRs holders' portions. The latest ETSI SR 000314 (ETSI SR 000314 V2.10.1, published in June 2011) reports 42 companies holding a total of 2749 essential IPRs for WCDMA, 1860 of which are included in our dataset. Among the 1860 essential IPRs, InterDigital, Nokia, Qualcomm, and Samsung Electronics hold roughly 70% of essential IPRs.

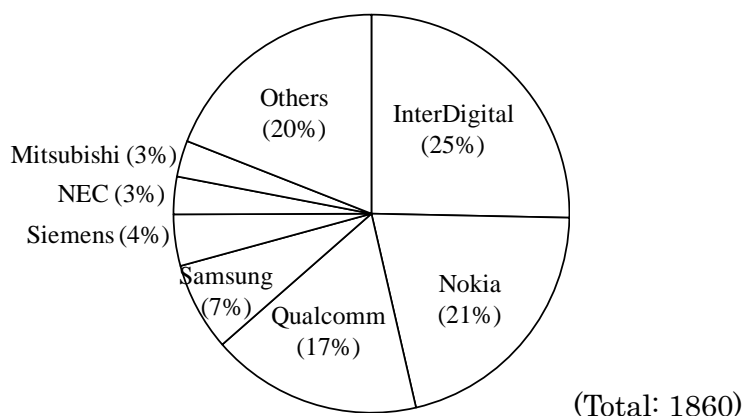

Figure 3.4. The portions of essential IPRs in our dataset

Bekkers and West (2009) analyzed the WCDMA essential IPR ownership in detail by using the relevant data through 2005. They compared essential IPRs in GSM and WCDMA. One of their contributions found that the number of essential IPRs in WCDMA increased approximately 8.8 times more than that of GSM. WCDMA is known to have its roots in GSM. In fact, Bekkers and West's result implies that many WCDMA innovations have achieved higher throughput<sup>17</sup> in WCDMA. The authors also identified the concentration of essential IPRs ownership. Although the share of GSM essential IPRs in the top four companies (eight companies) was 52.1% (72.9%), the share of WCDMA essential IPRs in the top four companies (eight companies) was 72.4% (90.5%). In Figure 3.4, the top four companies' share in our dataset is 70%. Thus, the general tendency seen in our dataset is the same as seen in their dataset.

In Section 3.1, I noted that technological advancement measured by the number of forward citations is a key factor for a patent to be deemed essential. Previous studies by Rysman et al. (2008) and Bekkers et al. (2011) derived this conclusion through analyzing forward citations. However, a question remains whether the forward citation increases after a patent is publicly deemed essential. Rysman et al. (2008) showed that the forward citations of essential IPRs increased after the disclosure. But, I would like to double test the question. Jaffe et al. (2000) sent survey questionnaires to inventors to understand the knowledge flow between the inventors of sampled patents and those of the patents cited by the sampled

---

<sup>17</sup> The amount of material or items passing through a system or process (Oxford dictionary). i.e. the transmission speed

patents. They found that 60% of the inventors were unaware about the patents that they cited before or while working on the invention. One issue is whether the number of forward citations of essential IPRs increases because the essential IPRs are publicly known by their owners' declaration. This issue should be clarified before analyzing forward citations of essential IPRs because if the number of forward citations increases after the originating patent is publicly known as essential, using the forward citations as an indicator of technological significance may be controversial.

Figure 3.5 presents the comparison of the annual number of forward citations. I searched the forward citations of essential IPRs. In Figure 3.5, I set the date when a patent is declared essential as Year = 0 and then recalculated the application date when the forward citations occurred. Figure 3.5 shows that more than 70% of forward citation occurred before essential IPRs were publicly known as essential. Many forward citations cited these patents 2–4 years earlier than they were declared essential. The earliest forward citation occurred nearly 15 years before its cited patent was declared essential. The application date used in Figure 3.5 is the US application date. Considering that the actual priority date is earlier than or equal to US application date, the ratio of forward citations before publicly declared essential IPRs is expected to be higher. Therefore, I can infer that the number of forward citations does not increase by the disclosure.

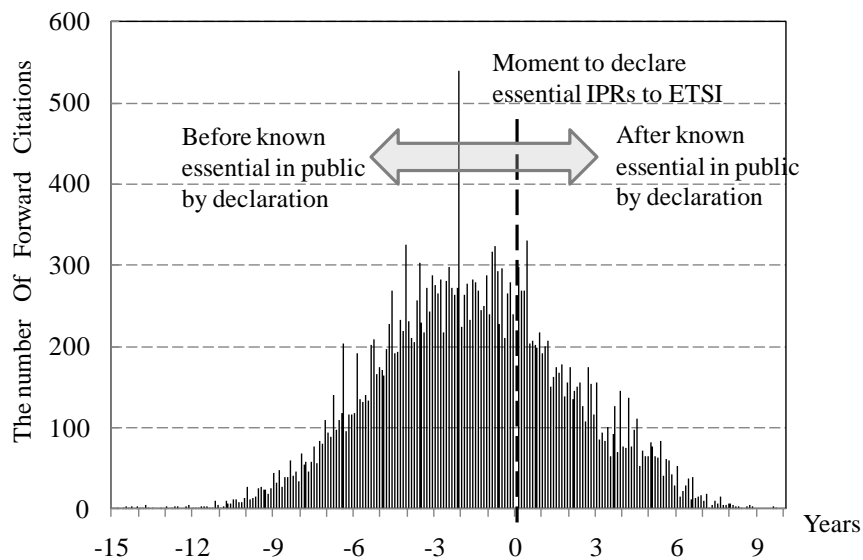

Figure 3.5. The number of essential patents' forward citations before and after the declaration of essential IPRs to ETSI.

### 3.4.3. Meeting attendees

Like the ETSI database, the 3GPP database is also publicly available (<ftp://ftp.3gpp.org/>). In the 3GPP database, I can find not only specifications for all 3GPP communications standards but also meeting information such as technical contributions, meeting minutes, and attendee information. I extracted all the attendee information in the 3GPP Radio Access Network Working Group 1 (RAN1).

Before describing the attendee information, I explain the 3GPP organization structure to improve the understanding of this research. The 3GPP comprises three levels of decision bodies. The highest of these is the Project Coordination Group (PCC), which meets once every six months to decide on the final adoption of 3GPP Technical Specification Group work items, ratify election results, and determine the resources committed to 3GPP. Under the PCC, there are Technical Specification Groups (TSGs) that decide the definition of the functions, requirements, and interfaces. Each TSG has Working Groups (WGs), one of which is RAN1. 3GPP RAN1 is responsible for the specification of the physical layer of the radio interface and is where technological discussions and negotiations between attendees take place.

In this study, I use the meeting attendees' information from 3GPP RAN1's first meeting (January, 1999) through its 58th meeting (August, 2009). I use information through only the 58th meeting, because our patent database covers only to 2009. The attendee information from the 3rd, 4th, and 5th meetings is missing. Figure 3.6 depicts the number of attendees from the first through 58th meetings. The number of attendees is nearly constant until the 40th meeting and significantly increases thereafter. The 58th meeting had 310 attendees. From this fact, I can assume that the standardization process has become more complex and competitive. The EPO PATSTAT provides inventors and assignee(s) information on patent applications. By manually matching inventor's names with the meeting attendees and the inventors' assignee(s) with the meeting participants' affiliations, I identified the inventors of patents from the meeting attendees' lists. I conducted matching the year by year to deal with inter-firm mobility of the inventors (Dokko et al., 2010). One may argue that location information can increase the reliability. However, the location information was not necessary because wherever an inventor is, his assignee is his company whether his location is in an office in home country or an office abroad. Instead, I believe that the IPC as introduced in Table 3.1

increased the reliability to the data because I could identify the inventors involved in air interface. First, EPO PATSTAT, in some cases, allocates different Inventor IDs to the same name because of reasons such as the abbreviations in inventors' names, the difference of capital and small letters in the names, inconsistent inclusion of middle names. Second, the table format for the 3GPP meeting attendees' list is not defined and was especially inconsistent in the early 2000s. After all the manual name-matching tasks, I removed statistical "noise" and obtained about 280 attendees matching our data set described in Section 3.4.1.

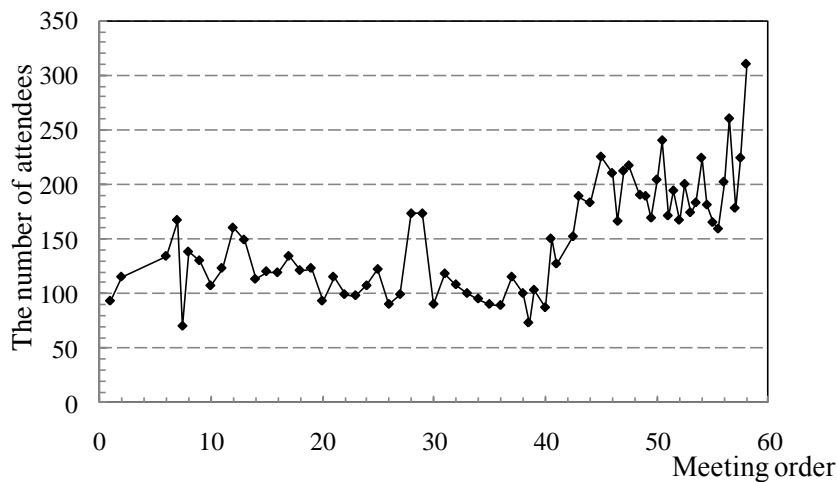

Figure 3.6. The number of attendees in 3GPP RAN1

Before performing the regression, I compared certain characteristics of attendees and non-attendees. The first comparison is the probability of one patent being essential. I set 1 if a patent was an essential IPR and 0 if not. I averaged all patents by attendees and non-attendees and compared them. The result is shown in Figure 3.7. The patents invented by attendees are threefold more likely to become essential than those by non-attendees. I also averaged the patents of each company on the same criterion, and that probability differed by company. However, in all cases, inventions by attendees have a higher probability of be disclosed essential than do those by non-attendees.

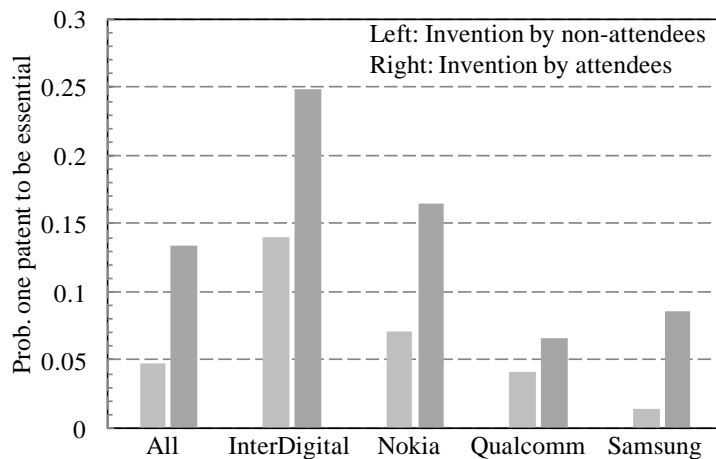

Figure 3.7. Comparison 1: A patent’s probability of becoming essential

In Figure 3.8, I compare the number of forward citations between attendees’ and non-attendees’ patent applications. As will be explained in Section 3.5.1, I must be careful when using the number of forward citations. Older patents tend to have more citations than newer patents. Instead, I use the relative number of forward citations, obtained by dividing the number of forward citations by the average number of forward citations from the same technological categories and the same application year. Figure 3.8 shows that the number of forward citations is higher for attendees’ patent applications. The gap differs for each company, but all four companies show the same general result. This consistent result suggests that attendees have more technological understanding and more technologically productive inventions than do non-attendees, and as a result they create more technologically important inventions.

The figure shows that all the patent applications used in this study have more than 1. This result is obtained because I included very recent patent applications in my dataset. For example, one forward citation of a patent applied recently becomes very big value when the value is normalized by the average. However, since I intended to compare between attendees and non-attendees, this concern may not affect the interpretation.

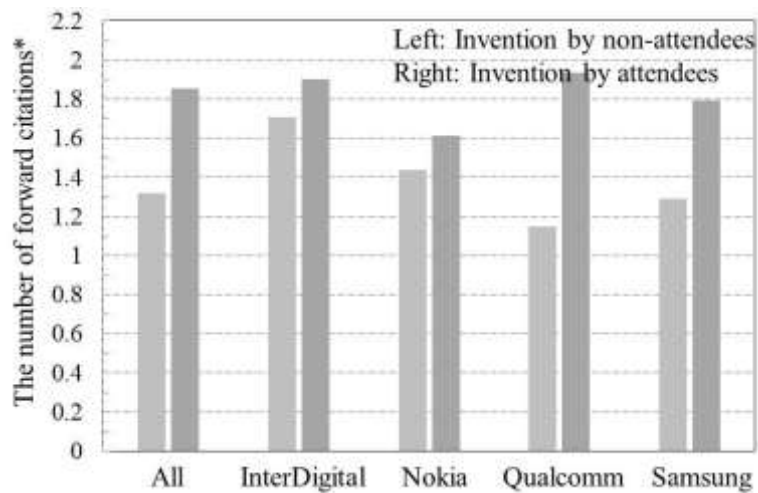

Figure 3.8. Comparison 2: The number of forward citations\* (the number of forward citations divided by the average number of forward citations from the same technological categories and the same application year)

Figures 3.9 and 3.10, respectively, compare generality and originality (Trajtenberg et al., 1997). As previously mentioned, generality is defined as how the follow-up technical inventions spread across different technical fields. If one patent is cited in various technological fields (i.e., high generality), the patent’s applicability to diverse technological fields indicates that it is fundamental and basic. In contrast, originality is defined as how the back-up technical inventions spread across different technical fields. If a patent cites various technological fields (i.e., high originality), the patent accumulates less specific technology, which indicates that it is “something new.” As seen in Figures 3.9 and 3.10, the difference between attendees and non-attendees shows a slight gap (much less than 10%) in generality and originality.



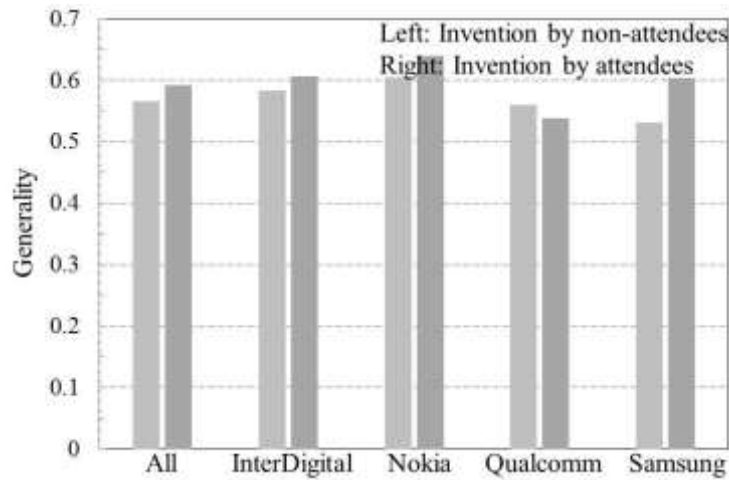

Figure 3.9. Comparison 3: Generality

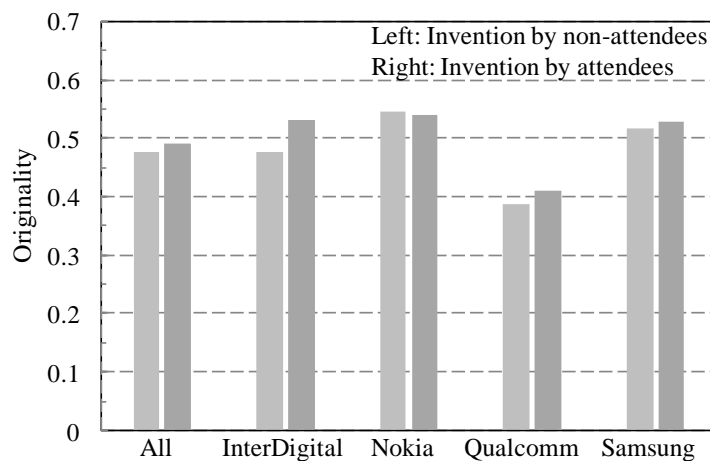

Figure 3.10. Comparison 4: Originality

Figure 3.11 and Figure 3.12 present how attendees' performance to invent and to obtain essential patents change over the years. I searched all the attendees and their patent applications. In Figure 3.11 and Figure 3.12, I set the first meeting year in which each attendee participated as Year = 0, and then recalculated the patent application date. Figure 3.11 shows how the number of forward citations of the patent applications invented by the attendees changes over time, and Figure 3.12 shows the probability for the attendees' patent applications to be declared as essential. The number of forward citations in each year is almost consistent except a few unusual jumps. Thus, in terms of the attendees' technological contribution does not change after they participate in the standardization meetings. On the other hand, the probability for the attendees' patent applications to be declared as

essential is not consistent. That is because the attendees stop participating in the standardization meeting at some point even if they apply patents. For the years between -4, i.e. four years before they participated in the standardization meetings, and 0, i.e. the first year they participated in, the probability increases. And, the years between +1 and Year +3 have high probability. All in all, Figure 3.11 and Figure 3.12 imply that although participation in the standardization meetings does not affect the technological ability of the attendees, it may affect the probability to obtain essential IPRs.

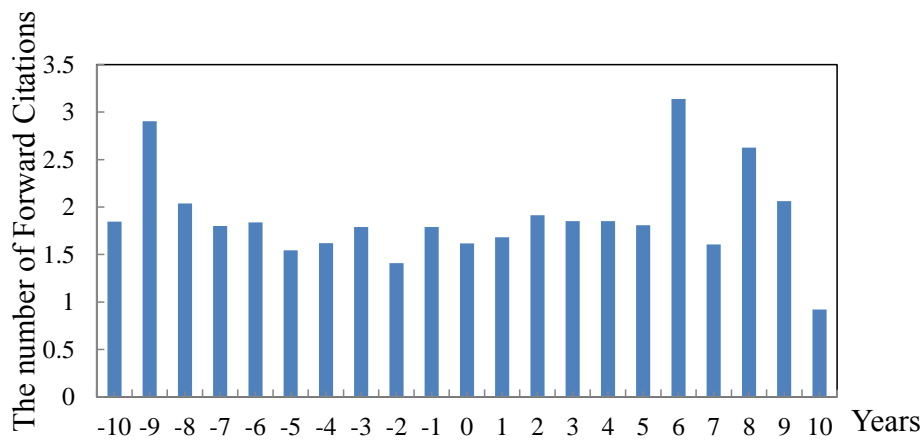

Figure 3.11. The number of forward citations of the patent applications by the attendees (Year=0: the first meeting year which an attendee participates in.

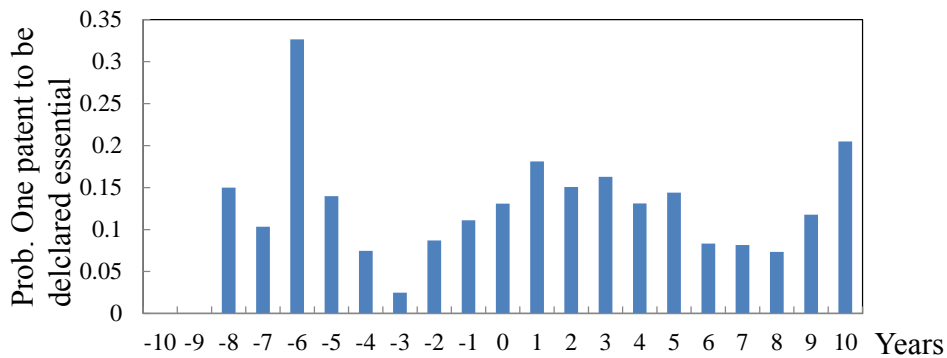

Figure 3.12. the frequency for attendees' patent applications to be declared as essential (Year=0: the first meeting year which an attendee participates in.

### 3.5. Results and Discussion

In this section, I test out hypotheses in three regression models. I test Hypotheses 1, 2, and 3, and Hypotheses 3-1, 3-2, 3-3, and 3-4 in two separate regression models. The former set uses the patent applications by both the attendees and the non-attendees. And, the latter set uses those only by the attendees because Hypotheses 3-1, 3-2, 3-3, and 3-4 are about the attendees' personal features.

#### 3.5.1. Regression 1

Hypotheses 1, 2, and 3 are tested in this section. The dependent variable is whether a patent application is declared essential. If a yes, the dependent variable equals 1; otherwise, 0. The first independent variable to test Hypothesis 1 is "Invention by Attendees," which equals 1 if any meeting attendee is found among the inventors in the patent of interest; otherwise, 0. The second independent variables to test Hypothesis 2 are RTA and PS. Both RTA and PS are calculated in the IPC subgroup unit. In most cases, a patent has more than one IPC; and therefore, I calculated the RTA and PS of each patent application in all member IPC subgroups and took the average. I added two interaction terms by multiplying the Manufacturer dummy. The third independent variables to test Hypothesis 3 are the number of essential IPRs in backward self-citations (Back EIPR Self), the number of non-essential IPRs in backward self-citations (Back NonEIPR Self), and the number of essential IPRs in backward non-self-citations (Back EIPR NonSelf). I added the interactions term by multiplying the Manufacturer dummy.

This analysis uses several control variables with the independent variables. The first control variable is the number of "Non-essential IPRs in Backward Non-Self citations" (Back NonEIPR NonSelf) together with its interaction term obtained by multiplying the Manufacturer dummy. This term is for the comparison with the other knowledge flows mentioned in Hypothesis 3. The second control variable is "The Number of Forward Citations." Several points merit discussion when measuring the technological significance by using the number of forward citations. First, it is now an accepted fact that the number of (either forward or backward) citations varies by technology field and application year (Nagaoka et al., 2010). Second, there is a time effect: newer patents have less probability of being cited by others compared to older patents. To overcome these limitations, I calculated the relative number of forward citations, obtained by dividing the

number of forward citations by the average number of forward citations from the same IPCs (H1Q, H03M, H04B, H04H, H04J, H04K, H04L, H04N 01, H04Q, H04W) and the same application year. In addition, for fair comparison, I considered only non-self-citations. The remaining control variables are Originality, the Number of inventors, the Manufacturer dummy, and the Prior Application year dummy (Year dummy in Table 3.2). The value of the Manufacturer dummy is set to 1 if the inventor's affiliation is either Nokia or Samsung Electronics; otherwise, 0. The value of the Year dummy is set to 1 according to the prior application year of each patent application.

Before moving to analyses, note that the number of observations,  $N$ , is less than 30,334. Because I used patents applied for only to the US PTO, certain independent variables (Generality, Originality, Number of essential IPRs in backward citations, and Relative forward citations) are derived from US PTO-to-US PTO patent citations. The patent applications that have citations of non US PTO-to-non US PTO are not used to estimate regression.

Our analysis uses the probit regression model, and the result is shown in Table 3.2, with the coefficients and  $t$  statistics of each independent variable. First, "Invention by Attendees" has a positive effect and statistical significance at the 1% level in all regression models. Invention by meeting attendees is found important in obtaining essential IPRs. Therefore, Hypothesis 1 is supported.

Second, RTA has positive effects and statistical significance at the 1% level in all regression models, whereas PS has the same tendency in only few models. However, the interaction terms with the Manufacturer dummy, "Manufacturer x RTA" and "Manufacturer x PS," have positive effects and statistical significance at the 1% level in all regression models. The slope shift due to the interaction term is positive, implying that manufacturers' essential IPRs are influenced by their core technological competencies measured by RTA and PS. As a result, Hypothesis 2 is supported for manufacturers.

Finally, I analyze Hypothesis 3. Both "Back EIPR Self" and "Manufacturer x Back EIPR Self" have positive effects and statistical significance at the 1% level in all regression models. Learning from a manufacturer's own essential IPRs had an effect on obtaining new essential IPRs. Hence Hypothesis 3-1 is supported.

“Back NonEIPR Self” has a negative effect and statistical significance at the 1% level. That is, knowledge from the manufacturer’s own non-essential IPRs negatively influenced obtaining new essential IPRs. However, “Manufacturer” = 1, the coefficient of “Manufacturer × Back Non-EIPR Self” is positive and has statistical significance at the 1% level. This result must mean that manufacturers did not develop their subsequent innovations on the basis of their non-essential IPRs but essential IPRs, so that Hypothesis 3-2 is also supported. “Back EIPR NonSelf” has a positive effect and statistical significance at the 1% level whereas “Manufacturer × Back EIPR NonSelf” does not. This result is understood to mean that for NPEs, knowledge from others’ essential IPRs influence obtaining essential IPRs. Thus, Hypothesis 3-3 is supported. Overall, Hypothesis 3 is supported.

		The number of essential IPRs in backward citations?	
		> 0	= 0
Self citation of Non-self citation in backward citations?	The No. of self citations	General: + Manufacturer: +	General: – Manufacturer: +
	The No. of non-self citations	General: + Manufacturer: No statistical significance	General: + Manufacturer: –

Figure 3.13. Result of knowledge flows

Additionally, analysis of several of control variables provided interesting findings. First, I observed that the Manufacturer dummy variable has a negative effect, but this result should not be understood to imply that not manufacturing companies need not hold essential IPRs. The data set used in this regression model has only two types of companies: manufacturing companies and NPEs. If Manufacturer = 0, the dummy variable indicates NPEs. Therefore, this result should be interpreted as implying that NPEs are more active to hold essential IPRs than manufacturers. Second, I need to explain the effect of “Back NonEIPR NonSelf.” “Back NonEIPR NonSelf” has a positive effect and statistical significance at the 1% level (Figure 3.13). Nevertheless, owing to the negative effect of “Manufacturer × Back NonEIPR NonSelf,” the coefficient becomes negative due to

the slope shift under Manufacturer = 1. Therefore, the knowledge flows from others' non-essential IPRs are positively effective for NPEs and negatively effective for manufacturers. On the basis of the conclusions obtained from other parameters of knowledge flows, I can infer that knowledge flow from its own non-essential IPRs is not beneficial for manufacturers in obtaining essential IPRs.

Table 3.2. Probit Regression 1.

Dependent variable: (Disclosed) Essential IPR (= 1), Non-Essential IPR (= 0)

	1	2	3	4	5	6	7	8	9	10	11	12
RTA	0.3874 [24.41]***			0.1925 [8.53]***	0.2293 [9.61]***	0.1521 [5.32]***	0.1717 [6.00]***	0.1614 [5.40]***	0.1683 [5.15]***	0.2048 [6.19]***	0.2011 [5.93]***	0.2069 [6.09]***
PS	0.0133 [3.47]***			0.0054 [0.88]	0.0142 [2.18]**	0.0011 [0.16]	0.0111 [1.51]	0.0075 [0.91]	0.0106 [1.12]	0.0124 [1.28]	0.0164 [1.65]*	0.0153 [1.54]
Back EIPR Self		0.1359 [10.47]***		0.125 [9.28]***	0.1361 [9.91]***	0.1495 [9.76]***	0.1399 [9.00]***	0.1249 [7.93]***	0.0985 [6.10]***	0.0979 [5.99]***	0.0917 [5.64]***	0.0914 [5.62]***
Back Non-EIPR Self		-0.0269 [-2.24]**		-0.0194 [-1.62]	-0.0247 [-2.05]**	-0.1332 [-5.33]***	-0.1535 [-6.16]***	-0.1162 [-4.63]***	-0.1388 [-5.38]***	-0.151 [-5.73]***	-0.1746 [-6.56]***	-0.1723 [-6.49]***
Back EIPR Non-Self		0.2633 [25.76]***		0.227 [21.56]***	0.2252 [21.43]***	0.2179 [17.05]***	0.1705 [12.41]***	0.1504 [10.84]***	0.1593 [10.48]***	0.158 [10.46]***	0.1487 [9.87]***	0.1508 [9.99]***
Invention by Attendees			0.6901 [26.11]***	0.4951 [12.56]***	0.5187 [12.98]***	0.5426 [13.26]***	0.5371 [13.04]***	0.5981 [13.82]***	0.5647 [12.31]***	0.5538 [11.94]***	0.5433 [11.34]***	0.5195 [10.60]***
Manufacturer dummy x RTA						0.3373 [6.04]***	0.318 [5.70]***	0.3434 [6.03]***	0.3685 [6.04]***	0.3299 [5.33]***	0.3322 [5.15]***	0.3213 [4.97]***
Manufacturer dummy x PS						0.1168 [6.42]***	0.1059 [5.79]***	0.1228 [6.49]***	0.1253 [6.02]***	0.1194 [5.61]***	0.1186 [5.41]***	0.1165 [5.30]***
Manufacturer dummy x Back EIPR Self						0.3345 [5.77]***	0.344 [5.93]***	0.3758 [6.35]***	0.4141 [6.62]***	0.4174 [6.61]***	0.4223 [6.68]***	0.4259 [6.74]***
Manufacturer dummy x Back NonEIPR Self						0.1061 [3.69]***	0.1289 [4.48]***	0.0796 [2.72]***	0.0994 [3.30]***	0.1079 [3.51]***	0.1301 [4.21]***	0.1279 [4.15]***
Manufacturer dummy x Back EIPR NonSelf						0.0023 [0.10]	0.0526 [2.26]**	0.0412 [1.75]*	0.0309 [1.25]	0.0277 [1.12]	0.0382 [1.53]	0.0341 [1.36]
Back NonEIPR NonSelf								0.0144 [8.36]***	0.0135 [7.75]***	0.012 [6.54]***	0.0113 [6.14]***	0.0089 [4.89]***
Manufacturer dummy x Back NonEIPR NonSelf								-0.0173 [-5.18]***	-0.0131 [-3.87]***	-0.0133 [-3.78]***	-0.0129 [-3.78]***	-0.013 [-3.58]***
Num of Forward Citation									0.0045 [2.31]**	0.004 [1.97]**	0.004 [1.91]*	0.0039 [1.83]*
Generality										1.0188 [9.80]***	0.9913 [9.17]***	0.9869 [9.12]***
Originality											0.278 [2.87]***	0.2813 [2.90]***
Num of Inventors												0.0261 [2.28]**
Constants	-1.9457 [-82.45]***	-1.8189 [-91.09]***	-1.8263 [-119.78]***	-2.0805 [-59.35]***	-2.2484 [-42.88]***	-2.045 [-37.64]***	-2.213 [-37.26]***	-7.3198 [-1.83]*	-7.1981 [-0.93]	-7.7859 [-1.25]	-7.9155 [-23.44]***	-7.9293 [-0.94]
Manufacturer dummy	No	No	No	No	Yes	Yes	Yes	Yes	Yes	Yes	Yes	Yes
Year dummy	No	No	No	No	No	No	No	Yes	Yes	Yes	Yes	Yes
N	30334	16638	30334	16638	16638	16638	16638	16638	11240	11240	10430	10430

\* p<0.1, \*\* p<0.05, \*\*\* p<0.01

### 3.5.2. Regression 2

Hypotheses 1-1 to 1-4 are tested in this section. I performed analysis from the individual inventor's viewpoint. The dependent variable is whether a patent application is declared as essential. If yes, then the dependent variable equals 1; otherwise, 0. The first independent variable is "Invention when the inventor acts as a meeting attendee (Hypothesis 1-1)," and is used as a dummy variable. If the

patent was applied for when its inventor was a meeting attendee, then this independent variable equals 1; otherwise, 0. Because I am using patents applied for to the US PTO, the application date to the US PTO may not be the original date. Therefore, to have an accurate invention date, I use the priority date only for this independent variable. The second independent variable of interest is the impact of an attendee's breadth of technological understanding (Hypothesis 1-2). As explained in Section 3.3, this is proxied by the average generality of all the patents for which each inventor applied. The third independent variable is used to test the number of solutions that an attendee can use for strategic discussions (Hypothesis 1-3). This is proxied by the number of inventions within one year before the date when the originating patent was invented. The last independent variable is an attendee's experience as an inventor (Hypothesis 1-4). The number of patent inventions for the originating patent application serves as a proxy. Other variables are used as control variables. In order to compare the difference in the strategy of manufacturers and that of NPEs, I made two types of regression models; Regressions models 1, 2, 3, 4, 5, and 6 use all patent applications by the attendees, and regression model 7 uses the attendees' patent applications that have at least one forward citation. Thus the latter is a subset of the former.

Our analysis used the probit regression model, and the result is shown in Table 3.3, with the coefficients and t statistics of each independent variable. As I mentioned earlier, the independent variables of interest are "Invention when an inventor acts an attendee," "Average Generality of an attendee," "the number of patents applied for within one year before the application for the originating patent," and "the number of patents applied for before the originating patent is applied for." Among these four variables, only "Invention when an inventor acts an attendee" shows interesting result. "Invention when an inventor acts an attendee" is positive and has statistical significance at the 1% level in all regression models when it is multiplied by the Manufacturer dummy (the interaction term). The other independent variables do not have statistical significance in all regression models. Hence, only H3-1, for manufacturers, is supported. This implies that the most important factor is the invention for the standard having been created while its inventor from manufacturers is actively participating in the standardization discussion.

It is worth discussing on endogeneity, i.e. inventors with many essential

IPRs are the most likely to attend committees and therefore get more essential IPRs. How does the experience as an attendee help get essential IPRs? Does the attendee experience help the inventor to have inspiration to invent what will become essential? Or, does the attendance at the meeting help bargain the invention to become essential? In order to answer the question, three phases are defined in an attendee's life time; "Invention before an inventor acts an attendee," "Invention when an inventor acts an attendee," and "Invention after an inventor retires an attendee (although he continues invention)." In the first phase, an inventor is not able to bargain his inventions nor have capability to understand what will become essential. In the second phase, an inventor is able to bargain his inventions at the meeting only when he participates at the meeting and also have the capability to understand what will become essential. In the last phase, an inventor is not able to bargain but has had the capability to understand what will come essential from the experience as an attendee. Thus, I can test the bargaining effect by comparing the second phase and the third phase, and the capability effect by comparing the first phase and the third phase. Accordingly, I performed the regression by setting "Invention after an inventor retires an attendee" as the base. From regression models 5, 6, and 7 in Table 3.3, "Invention when an inventor acts an attendee" is positive and has statistical significance at the 1% level in all regression models when it is multiplied by the Manufacturer dummy. The result implies that manufacturers tend to bargain their technology to have it essential. I develop further discussion on regression 7 on the difference in the strategy of manufacturers and that of NPEs. As mentioned above, regression model 7 uses the attendees' patent applications with at least one forward citation. As discussed in Section 3.4.1, forward citation implies knowledge flow which influences subsequent inventions. Thus, I interpret that the patent applications with at least one forward citation are fundamental enough to affect subsequent inventions. "Invention when an inventor acts an attendee" is larger than "Invention after an inventor retires an attendee" for both NPEs and manufacturers. However, for NPEs, "Invention before an inventor acts an attendee" is smaller than "Invention after an inventor retires an attendee," and the similar tendency is not observed in case of manufacturers. This difference can be explained by their strategies. As observed in Table 3.2 and Figure 3.13, manufacturers try to exploit their own competency to the standardization while NPEs try to exploit prior standard knowledge to the standardization. Thus, in case of manufacturers, the competence that is obtained before an inventor acts an attendee is exploited at the standardization, and the



competence affects to get essential IPRs that are fundamental to the subsequent inventions. However, since manufacturers' interest is not in essential IPRs per se but in market, once the competence is exploited at the standardization, the attendee may retire from the standardization and return to his original R&D activity. On the other hand, since licensing is the only revenue for NPEs, even if an attendee retires the standardization, he will be still involved in the standardization indirectly. Thus, the standardization experience remains as a capability for an inventor who retired an attendee to get essential IPRs, and that experience is reflected in regression 7 where "Invention before an inventor acts an attendee" is smaller than "Invention after an inventor retires an attendee".

Table 3.3 Probit Regression 2.

Dependent variable: (Disclosed) Essential IPR (= 1), Non-Essential IPR (= 0)

	1	2	3	4	5	6	7
Invention before an inventor acts an attendee	-0.0043 [-0.11]		0.2716 [5.27]***	0.2533 [4.85]***	0.2012 [3.16]***	-0.0799 [-1.04]	-0.2386 [-2.17]**
Invention when an inventor acts an attendee		0.1776 [4.85]***	0.3873 [8.03]***	0.393 [8.05]***	0.1707 [2.82]***	0.0667 [0.98]	0.1878 [1.85]*
Average Generality of an attendee			0.0177 [2.02]**	0.0138 [1.50]	-0.0125 [-0.64]	0.028 [1.30]	-0.015 [-0.46]
The No. of patents applied within one past year from the application of the originating patent			-0.0136 [-8.75]***	-0.0162 [-9.95]***	-0.0174 [-10.15]***	-0.0093 [-5.11]***	-0.005 [-1.44]
The No. of patents applied until the originating patent is applied			0.0013 [3.27]***	0.0006 [1.52]	0.0008 [2.03]**	0.0008 [1.66]*	0.0002 [0.26]
[Manufacturer dummy] x [Invention before an inventor acts an attendee]					0.0726 [0.62]	0.1406 [1.10]	0.1888 [1.12]
[Manufacturer dummy] x [Invention when an attendee acts an inventor]					0.5738 [5.29]***	0.6379 [5.52]***	0.5409 [3.40]***
[Manufacturer dummy] x [Average Generality of an attendee]					0.0305 [1.38]	-0.0211 [-0.85]	-0.0228 [-0.39]
[Manufacturer dummy] x [The No. of patents applied within one past year from the application]					0.0297 [4.38]***	0.0189 [2.60]***	0.0183 [1.75]*
[Manufacturer dummy] x [The No. of patents applied until the originating patent is applied]					-0.0058 [-3.36]***	-0.0025 [-1.39]	-0.0043 [-1.41]
The No. of forward citations						0.0049 [1.54]	-0.0068 [-0.99]
The No. of inventors						-0.0024 [-0.24]	0.0061 [0.50]
The No. of essential IPRs in backward citations						0.1431 [17.81]***	0.1225 [14.12]***
Manufacturer dummy	No	No	No	Yes	Yes	Yes	Yes
Year dummy	No	No	No	No	No	Yes	Yes
Constant	-1.108 [-50.35]***	-1.1834 [-49.34]***	-1.2345 [-26.85]***	-1.0137 [-19.28]***	-0.8422 [-11.79]***	-1.2108 [-10.40]***	-4.0948 [-0.03]
N	7618	7618	7618	7618	7618	7612	3241

\* p<0.1, \*\* p<0.05, \*\*\* p<0.01

### **3.6. Conclusions and policy implications**

Interest in essential IPRs has been increasing in the wireless communications industry. Studies have sought the determinants for obtaining essential IPRs. In this study, I focused on previously untested items. First, I tested the effect of core technological competencies on essential IPRs. I measured core technological competencies by introducing RTA and PS. RTA represents core technological competency compared to other technological competencies within a company, and PS represents core technological competency compared to other companies' competencies. I found that these parameters are positively effective, especially for manufacturing companies. As a result, I can conclude that it is important to obtain essential IPRs derived from a company's core technological competency. Second, I analyzed the difference in technology strategy between manufacturers and NPEs. I divided the types of backward citations of patents on two dimensions: whether cited patents are essential IPRs and whether citations are made to a firm's own patents. I found that subsequent innovations by manufacturers are based on their own technologies, regardless of whether they are essential patents. By contrast, those by NPEs are based on essential patents, regardless of whether they are their own patents. Finally, I tested the effect of the inventor's attending a standards meeting on his patent's becoming an essential IPR, which is the core contribution of this study. For the analysis, I used 3GPP RAN1's attendees list from the first through 58th meetings, together with a patent database and essential IPR list. By comparison with the patent statistics of non-attendees, I found that (1) patents invented by attendees are more likely to be essential than those by non-attendees, and (2) patents invented by attendees have more forward citations than do those by non-attendees. In addition, I conducted the in-depth analysis about the attendees. I found that the behind of their involvement was their bargaining power, especially for manufacturers, to get essential IPRs. As observed from RTA and PS, it seemed that manufacturers obtain essential IPRs in their specialty, but it turned out that they bargain their specialty in the standardization. That behavior is not preferable because a standard must be defined so as to accelerate further innovation in the industry.

This study suggests that some differences exist between the technology strategies of manufacturers and non-practicing entities (NPEs). A policy goal of standardization is to stimulate innovations by establishing common technology bases on which firms fairly compete. Both manufacturers and NPEs

contribute to this process, but I found that manufacturers focus more on subsequent innovations based on the standards, whereas NPEs contribute more to upgrading the technology standard itself. In this sense, manufacturers and NPEs complement each other. However, to facilitate the process, licensing requirements for essential IPRs, such as the RAND condition, must be implemented strictly. In addition, manufacturers tend to have fewer incentives for listing their patents as essential IPRs than do NPEs because non-essential IPRs that differentiate their products generate significant revenue. Therefore, this study suggests that standards organizations devise a policy providing an appropriate incentive design for manufacturers to contribute to the standardization upgrading process. Otherwise, they may focus on proprietary technologies.

Another major contribution of this study is providing evidence of the complementarity between standardization and invention activities, by observing these activities at the inventor level. Participation in standardization meetings, as well as informal discussions with researchers from other firms (competitors in the product market) serves as an important information channel. A standardization meeting is not only a place for negotiating technology standards but also a forum for open innovation through information exchange among standardization participants. Therefore, this study suggests that such information is highly useful for a firm's technology strategy planning, including external R&D collaborations, as a matter of corporate policy.

#### **Appendix A: Compact business history description of InterDigital, Nokia, Qualcomm, and Samsung Electronics.**

**InterDigital:** InterDigital was founded in 1972 as International Mobile Machines Corporations, and renamed in 1992. InterDigital was one of the first manufacturers in US which developed a portable analog radio system. However, in 1980s, the company started to focus on patenting its inventions in communications technology and licensing the patents. Although the company had its manufacturing unit, the business unit counted a very small part of InterDigital's profit. In 1999, InterDigital gave up its manufacturing unit and became as a technology developer and licensor.

**Ericsson**<sup>18</sup>: Ericsson, one of the most successful Swedish companies, has been a dominant player in communications industries for more than a century. Ericsson is the oldest company in communications industry. Ericsson was founded in 1876 in Sweden by Lars Magnus Ericsson. It was launched as a telephone and switchboard manufacturer. Ericsson expanded its business globally from the late nineteenth century. Ericsson was one of the firms which initiated and led cellular system in the twentieth century. Currently, Ericsson's main business is to provide network systems to network operators.

**Qualcomm** (Mock, 2005): Qualcomm was founded in 1985. Starting its business in satellite communication services, Qualcomm developed and commercialized a CDMA-based cellular system in 1990s. When the CDMA-based cellular system was standardized as IS-95, Qualcomm began to grow very rapidly. All the firms using the CDMA-based cellular standard paid license fee to Qualcomm. However, after selling its base station business unit to Ericsson and its cell phone business unit to Kyocera, Qualcomm became as a technology developer and licensor. Although InterDigital remained as a pure technology developer and licensor, Qualcomm became a fabless semiconductor company, and has been ranked as the top fabless company in sales recently.

**Samsung Electronics** (Son, 2013): Samsung Electronics was founded in 1969 as Samsung Electric Industries in Korea, and was renamed in 1988. It started its business in home appliances. Samsung Electronics expanded its business by acquiring firms. Samsung Electronics entered semiconductor industry and communications industry by acquiring Korea Semiconductor in 1974 and Korea Telecommunications in 1980, respectively. The company achieved unprecedentedly rapid growth in Korea in 1990s and 2000s in various industries. Now Samsung Electronics has business in TV, LCE/LED panels, semiconductors, mobile phones, and home appliances.

---

<sup>18</sup> <http://www.ericssonhistory.com>

## Chapter 4: Just-in-time inventions and the development of standards: How firms use opportunistic strategies to obtain standard-essential patents (SEPs)<sup>19</sup>

### 4.1. Introduction

Recent years have witnessed an explosion of lawsuits about patents primarily built on standards: smartphones and mobile phones, tablets, personal computers, video consoles, and more. Many well-known companies like Apple, Samsung, Motorola, Nokia, Google, HTC, Microsoft, Kodak, and Research in Motion are involved. And this situation might be further exacerbated by the appearance of non-practicing entities (NPEs). Such companies are found to be particularly keen on acquiring patents in the above industries (Fischer et al., 2012). In these cases, a particularly important role is reserved for so-called Standard Essential Patents (SEPs), also simply referred to as essential patents. These patents are by definition required in order to implement a given standard. Consequently, any company implementing that standard will by definition infringe on such patents unless it has a licensing agreement with the patent owner. Because essential patents are particularly powerful and may give rise to abuse, such as refusal to license and hold-up pricing (Shapiro, 2001; Lemley et al., 2007), standard setting organizations created special regimes under which essential patent holders are requested to disclose these patents and commit themselves to license essential patents to any implementer of the standard on the basis of fair, reasonable and non-discriminatory (FRAND) prices and conditions. Many of the lawsuits are actually about these licensing commitments.

Companies owning SEPs have a range of benefits, such as revenue

---

<sup>19</sup> This chapter is also appeared in: Byeongwoo Kang, and Rudi Bekkers, “Just-in-time inventions and the development of standards: How firms use opportunistic strategies to obtain standard-essential patents (SEPs),” Eindhoven Center for Innovation Studies (ECIS) working papers 13.01.

generating opportunities (every implementer of the standard is by definition infringing and thus a potential licensee), a good bargaining position for cross licenses gaining access to both SEPs and non-SEPs, and more. Also on a higher level, Blind et al. (2011b) found that the ownership of essential patents boosted firms' financial returns, and Aggarwal et al. (2011) provide empirical evidence of the influence on stock market returns. Given the attractiveness of owning such patents, it will come as no surprise that companies that do not have any (or believe they have too few) regularly try to purchase them, often at quite astonishing prices. We will give two examples here. In 2010, a consortium that included Apple, Microsoft and RIM acquired a significant part of the patent portfolio of the former Canadian firm Nortel for US\$ 4.5 billion. This portfolio is believed to contain a large number of essential patents for 4G technology, among other standards. In 2011, Google purchased Motorola Mobility for US\$12.5 billion, and many believed this was mainly done to acquire ownership of the company's patent portfolio. These transactions are probably the best illustration of the value that companies attach to essential patents, even though we have to bear in mind that in both examples, the portfolios obviously also included non-essential patents.

But how do companies obtain essential patents in the first place? To answer this question, we need to go back to the standardization process. Most standards are developed in open standard setting organizations, using a set of rules, of which consensus among the participants is an important one. In principle, any interested party can become a participant. In the case of telecommunications or IT technology, it is usually the companies that participate. At Technical Committee (TC) meetings with comparable groups, they discuss technical approaches in order to meet the standards' design requirement and eventually determine – on the basis of consensus – the final version of the standard. The Technical Committee may include technologies patented by the participants, but may also (knowingly or not) incorporate technologies covered by others' patents. For many modern telecommunications or IT standards, it is not unusual that the final standards incorporate many patented technologies, sometimes up to thousands – these are the essential patents. Inclusion of such patented technologies can be a good thing, as these may improve the standards' performance, cost-effectiveness, or environmental friendliness, to name but a few things. In such cases, the cost of essential patents (licensing costs but also the resource-consuming licensing negotiation processes) may be worth the additional value of the standard. However,

if such patents are included without contributing substantially to the standards' value, it could be considered suboptimal from the public perspective (yet perhaps optimal from the individual patent owner's perspective).

In recent years, several insiders have raised the issue of such undesirable inclusion of patented technologies. Some insiders have even expressed concerns over this process, whereby parties can propose technologies *“just for getting patented technology into the standard rather than to improve the standard [...] No mechanism exists to determine whether a patent claim brings a standard forward (real innovation) or just tries to get a patent into the standard in order to make money.”*<sup>20</sup> One such strategy was recently outlined at a conference by the former director of a large multinational's research lab. He explained how he would send staff to a standardization meeting, and right after the meeting, in the hotel room, they would brainstorm how to combine elements mentioned by other participants, and then immediately prepare patent applications on these. (See more about this process in Section 4.3, below). Also direct observations by the authors when attending standardization meetings revealed how companies were strategically filing patents just before as well as during the standardization meetings, in order to have these technologies included in the specified standard.

In this study, we call the phenomenon of strategically filing patents during or just before standardization meetings, 'just-in-time' inventions, which result in 'just-in-time patents'. We highlight the differences in patent filing between those who participated in these meetings, and those who did not. Section 4.2 starts by discussing previous literature on essential patents and the way they came into existence. In Section 4.3 we discuss the standardization process and develop hypotheses concerning just-in-time inventions. In Section 4.4 we introduce our data and present our findings. In Section 4.5 we close with conclusions and a discussion.

---

<sup>20</sup> Presentation by Dirk Weiler (Chairman of the ETSI General Assembly and Chairman of ETSI's IPR Special Committee) titled 'Standards Related Patent Quality: A view from a standardisation organization. Presented at the EC/EPO Workshop on "Tensions between intellectual property rights and standardisation: reasons and remedies". Brussels, November 22, 2010. Available from [http://ec.europa.eu/enterprise/sectors/ict/files/ict-policies/5\\_weiler\\_en.pdf](http://ec.europa.eu/enterprise/sectors/ict/files/ict-policies/5_weiler_en.pdf).

## 4.2. Existing literature on standard essential patents

In the past two decades, there has been an increasing interest and amount of literature on standards in patents. In this section, we will review that literature, and identify what we consider as the relevant remaining gaps in that knowledge.

The existing literature is varied in its nature and can, roughly speaking, be divided into the following categories: (1) the existence of standard essential patents, (2) features of standard essential patents, (3) effects of standard essential patents on the standardization process, (4) effect of standard essential patents on the market (including antitrust/competition concerns), and, finally, (5) firm strategic behavior regarding standard essential patents. We will briefly review these bodies of literature.

**The existence of standard essential patents.** Over time, researchers and policy makers became increasingly aware of the phenomenon of patents in standards. While initial insights were on a case by case basis, the first more systematic approaches to understand this phenomenon were performed by Rysman & Simcoe (2008), who also created a public database known as [ssopatents.org](http://ssopatents.org). A few years later, a large-scale empirical fact-finding study commissioned by the European Commission (Blind et al., 2011a) showed that the standards developed by eleven of the largest standard setting organizations incorporated well over 4000 (claimed) essential patent families, yet the distribution is very skewed – both between standards and in ownership. Since not all these standard setting organizations require their members to disclose the identity of every individual essential patent (family) they own, the actual number is probably considerably higher. In 2012, several researchers in this area took the initiative to develop a large, up to date database of standard essential patents, which is in fact also one of the main data sources for this study (Bekkers et al., 2012).

**Features of SEPs.** A second line of research has investigated in what respect standard essential patents are ‘different’ from regular patents. Rysman and Simcoe (2008) observed that, on average, essential patents have a higher forward citation score than comparable, non-essential patents. This could be interpreted as standards enabling the selection and integration of valuable technologies. While these are important findings, we should bear in mind that there are still key issues on cause and effect; for instance, patents may receive additional citations after they



are included in a standard. If the standard is successful, then companies will direct their R&D efforts towards inventions related to that standard (either as complementary technology, or perhaps essential patents for future generations of that standard); with such directed R&D efforts, the likelihood that essential patents are cited increases. These efforts can result in the problem of endogeneity, and while such forms are difficult to correct, Rysman and Simcoe (2008) try to do so by comparing the received citations before and after the patent was disclosed by its owner as being essential to the standard.

**Effects of SEPs on the standardization process.** In various ways, the existence of essential patents can have an impact on the standardization process as such. Among other things, there is the problem that a single patent can fully block the standardization processes, potentially creating a need to halt work altogether, or withdraw an issued standard (see Farrell et al. 2007). But there are also more indirect effects. Dokko and Rosenkopf (2010), for instance, have shown how companies owning patents have a greater influence on the decisions in standardization processes. The existence of standard essential patents may also have an impact on the lifetime of standards. In a recent paper, Baron et al. (2012) provide evidence that essential patents reduce the likelihood of standard replacement. As such, the authors argue, essential patents may lead to a “lock in” of outdated standards, rather than encourage investment and increase the pace of standardization.

**Effect on the market and antitrust/competition.** Perhaps even more challenging are the effects essential patents have on the market that is served by these standards. In fact, such effects are the main legitimacy of the specific rules many standard setting organizations have adopted for such patents (see Section 4.3). Among the concerns are patent hold-up, royalty stacking, and ambush/patent blocking (Lemley & Shapiro, 2007). Given such concerns, there is an increasing amount of policy literature on antitrust/competition aspects and other consequences of strategies with SEPs, which is well summarized in a recent special issue of the Antitrust Bulletin (see Besen & Levinson, 2012), the book of the American Bar Association on the Antitrust Aspects of Standards Setting (Kobayashi & Wright, 2010), and the 2011 US Federal Trade Commission report, The Evolving IP Marketplace (FTC, 2011). Others, however, stress that there is no direct evidence for royalty stacking and note that licensing rates are typically high in the

industries in question, which is not necessarily a consequence of stacking (e.g. Geradin et al. 2008).

**Firm strategies with regard to SEPs.** The body of literature most closely related to the focus of our paper, and perhaps also the most fascinating part, concerns research on firm strategies for essential patents. Since few now doubt the huge attractiveness of owning such patents, how do companies obtain them? To what degree do they reflect genuine R&D and contribution of knowledge with a high technological merit (a strategy in itself), and to what extent are they the result of their owners' specific conduct? And what is this conduct exactly? In her study on the standardization of the 3G W-CDMA standard, Leiponen (2008) focuses on the role of private alliances, highlighting industry consortia. By being part of such alliances and consortia, firms increase their chances of having their own (patented) technical contributions accepted in the standard. Bekkers et al. (2011) studied the determinants of patents being (claimed) essential. They found that patents with a high value ('technical merit') have an increased likelihood of becoming (claimed) essential, but the patent owner being an active participant was a much better determinant. One possible strategy is that firms use continuation patents in order to obtain patents that are essential to technical standards, as argued by Omachi (2004). Along the same line of thought, Berger et al. (2012) find that patent applications which are eventually disclosed as being standard-essential, are amended more often than other, otherwise comparable patents. Arguably, firms amend these patents to add claims to the patents that will eventually be essential to implement the standard.

Taking into account the current literature on patents and standards, we appreciate the wide variety and depth, but also conclude that knowledge on how companies obtain essential patents in the first place, examining in more depth their actual conduct during the standardization process as such, remains scarce. This is the gap in the literature our contribution aims to address.

#### **4.3. Hypotheses on essential patents and the standardization process**

Standardization is a voluntary process, where interested parties come together and aim to reach a consensus on the exact content of a standard. These interested parties may include companies that are prospective implementers of the

standard, as well as technology developers, end users, intermediate users (such as network operators in telecommunications), component suppliers (such as manufacturers of chip sets or software), and more. Also public entities like national governments may participate. Obviously, different participants may have different preferences, depending on their own (market) situation, their technological strengths and weaknesses, preferences of their clients, and so on.

Standard setting organizations were established to facilitate the standardization process, but it is important to stress that standards are created by participants, not standard organizations themselves. To secure basic principles such as openness, neutrality, and to ensure their activities are not considered as collusive or anti-competitive by competition or antitrust authorities, standard setting organizations have developed sets of rules, which are usually binding upon their members or participants. Rules about patents that are essential to implement their standards are usually so-called IPR rules. Usually these include requirements to disclose essential patents (i.e. informing the standard setting organization (SSO) when a party believes it owns such patents) and requests to make a commitment to license such patents at certain conditions (such as F/RAND: Fair, Reasonable and Nondiscriminatory conditions). Nevertheless, there is quite some variance in the exact rules applied by various SSOs. Lemley (2002) was among the first to analyze this institutional variety, whereas Chiao et al. (2007) empirically explored standard-setting organizations' policy choices. A comprehensive and up to date review is provided in a recent report commissioned by the US National Academies of Science (Bekkers & Updegrove, 2012).

As discussed in the introduction, an essential patent is one that covers a technology which is indispensable in order to produce a device that implements the standard; there is simply no alternative but to use this patented technology. So essentiality depends on the exact scope of the patent (the language in the patent claims) and on the exact content in the standard (the wording of its specifications). So when do patents become essential? Different situations are conceivable. Firstly, the people drafting a standard may include a technology that was already developed and patented long before discussions on the standards began. They might do so because they realize this patented technology is the best way or even perhaps the only way to create a standard with agreed functional specifications. It might increase performance, be cost-effective, save energy consumption, etc.

Patented technologies with extraordinary technical merit are likely to be recognized by all participants and do not necessarily require the patent owner to participate in ‘pushing’ the patent in. Secondly, technical challenges or trade-offs can arise while working on the standard, and participants perform R&D and use their knowledge to address these. Indeed, some may come up with very original and creative solutions, for which they might apply for patents right away. In this case, the patent filing is parallel in time to the standardization effort. Lastly, companies may try to apply for patents and get this technology included in the standard, even if it does not offer great improvements or technical merit to the standard. There are strong incentives to do so, because, as we have seen, owning an essential patent offers great advantages. Whether the patent has great technical merit or not, the advantages are there to enjoy – just the mere fact that the specification of the standard is written in such a way that it overlaps with the language in the patent claim is sufficient. When patents are applied for just before or during standardization meetings, we will refer to them as *just-in-time patents*.

On the basis of the above, we postulate that there is a huge incentive for firms to try and obtain essential patents. Submitting technical proposals for the standard (in 3GPP that can be done electronically in advance of the meeting) and/or participating at meetings can help to accomplish this goal. At the meeting, you can plea to have your technology included, or perhaps bargain with others to obtain votes for inclusion, in return for other favors such as returning votes for other decisions. The submissions and other meeting information, which in 3GPP is instantly made electronically available to non-participating members, also allows companies to consider other parties’ ideas, combine or recombine and subsequently file patents on these. We assume standardization meetings play a pivotal role in obtaining essential patents, and that the mechanisms discussed above result in a cyclic relationship between essential patent filings and the occurrence of standardization meetings. More specifically, we formulate the following hypotheses:

*Hypothesis 1: There is an increased intensity in essential patent filing just before and during a standardization meeting.*

While the above hypothesis considers those patents that are eventually disclosed to be essential, it does not yet reveal the likelihood that a given patent

will become essential. In line with the arguments above, we would expect that those people who participate in meetings increase this likelihood by pleading and bargaining, while those not attending the meetings are not able to increase this likelihood. Our related hypotheses are thus:

*H2. Patents applied for just before or during a standardization meeting have an increased likelihood to become essential patents*

It was argued above that there might be a difference in technical merit, depending on when the patent was filed and the strategy of the filer. Patent citations are, arguably, the best indicator of technical merit for a study of this type (we will refer to this measurement later). While earlier studies have already shown that essential patents, on average, receive more citations than non-essential patents that are otherwise comparable, we predict here that there are differences *between* various types of essential patents. More specifically, we expect that essential patents filed just before or during a meeting are of lower merit (i.e. receive fewer citations) than essential patents filed at any other time.

*H3. Standard essential patents applied for just before or during a standardization meeting have a lower technical quality than comparable patents*

Finally, it might be the case that incentives to engage in just-in-time patenting vary as a result of a firm's different positioning. There might be differences as a result of the business model (e.g. upstream vs. downstream in the knowledge market), and with firms that have been part of the 'essential patent game' for many years versus newcomers. While we are interested to learn about such differences, we have no specific a-priori expectations here, so we will not postulate any hypotheses.

For all the above hypotheses, please note that when we refer to essential patents, we mean those patents that are claimed by their owner to be essential, since we have no objective means of testing whether they are actually essential. Also, note that such claims are usually only made after it has become clear what the standard really looks like, which may be long after the actual meeting. So, in this paper, when we talk about 'essential patents', we mean specifically patents eventually disclosed by their owner as being essential to the standard.

#### 4.4. Data and findings

To test our hypotheses, we turned to the development of the W-CDMA<sup>21</sup> and LTE standards, the most successful global technologies for respectively 3G and 4G mobile telecommunications. Their standardization efforts took place in an organization called Generation Partnership Project (3GPP), which is a partnership of several regional standard setting bodies, including Europe's ETSI as well as Japan's ARIB and South Korea's TTA. The direct successor of the successful 2G GSM standard, the W-CDMA/LTE standard that we focus on, already has over a billion worldwide users,<sup>22</sup> a number that is expected to grow considerably as more advanced services are adopted in both developed and developing countries around the globe. The development of the standards discussed here was anything but dynamic. While the first version of W-CDMA was released in early 2000, the standard saw numerous improvements in later years. Over time, new specifications were added such as HSPA, to improve data transmission speeds. In fact, over a period of a decade, these data transmission capacities gradually increased to a factor of almost one thousand higher than the original version.<sup>23</sup> In addition, the development of the 4G LTE standard was evolutionary, smoothly integrating in the existing activates.

These constant improvements in W-CDMA and LTE, discussed at numerous meetings over more than 10 years, make this a very attractive case study to test our hypotheses. Also the availability of data on meeting participation and essential patents make this case particularly suitable. Furthermore, the nature and volume of that data (77 meetings at quite regular intervals, 939 individual participants at these meetings, affiliated with 53 different firms, as well as over 14,000 patents in

---

<sup>21</sup> In Europe, the W-CDMA standard is also known as UMTS, although technically speaking, the latter has a somewhat wider technical scope. Worldwide, the W-CDMA is also known as 3GPP, after the name of the partnership.

<sup>22</sup> Based on statements from the Global mobile Suppliers Association (GSA) and Informa Media & Telecom.

<sup>23</sup> The first version of the 3GPP standard, known as R99, included specifications for data transport up to a transmission speed of 384 kbit/s. Release 11 of this standard, finalized in the third quarter of 2012, includes a data transmission mode known as HSPA+, which provides speeds of up to 337 Mbit/s.

the relevant technology area, of which 988 are claimed essential) are attractive for putting our hypotheses to the test.

We also collected data on all the meetings of the 3GPP RAN1 group. This is the group responsible for the physical layer of the radio interface, thereby defining the most central element of the standard. We collected all the data, starting with this group’s first meeting (held January 21-22, 1999) to what is known as the 60th meeting (held February 22-26, 2010). In fact, there were a total of 77 meetings in the considered period (the numbering by 3GPP is not always sequential; there might be a *27bis* meeting, for instance), so the average spacing between the start days was slightly under two months (52 days). For our study, we also examined the period of several days preceding each meeting, called here the ‘pre-meeting period’. A schematic of the timing of meetings is presented in Figure 4.1.

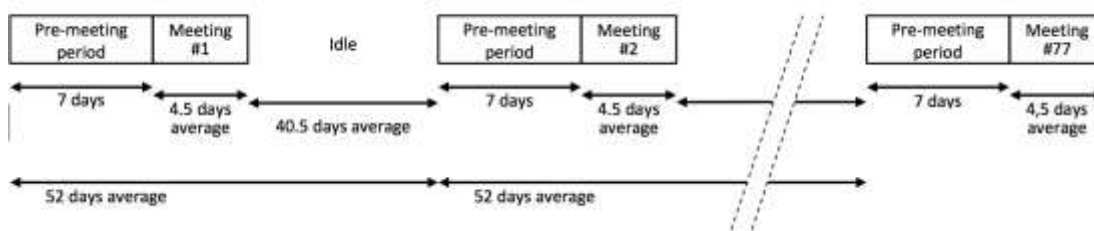

Figure 4.1: Schematic presentation of the occurrence of 3GPP RAN1 meetings.

Data on claimed essential patents was retrieved from the public Open Essential IPR Disclosure Database (OEIDD). This database, first presented at the NBER in early 2012, includes harmonized data of over 40,000 patent disclosures at main standardization bodies (Bekkers et al., 2012). The relevant W-CDMA and LTE entries in this database were matched with PATSTAT, the comprehensive patent database developed by EPO and OECD, providing us detailed metadata on patent families and inventors, among other things. This was complemented with additional data on firms’ business models, home region and so on from other sources.

#### 4.4.1 Testing the first hypothesis: Relationship between patent filing and meeting occurrence

The first hypothesis considers whether there is a cyclic pattern in (preliminary) patent filings, induced by the meeting schedule. Table 4.1 shows the

findings. Here, the first row (‘pre-meeting’) shows the patenting intensity for all the periods of 7 days that precede the meetings we consider. (Since there are 77 meetings in our analysis, the cumulative length of these periods is exactly 77 weeks.) The second row shows the patenting intensity for all the days on which the actual meetings took place. Since the average meeting length was four and a half days, this adds up to a total of 51 weeks. The third column (Idle) shows the patent intensity for all remaining periods in between the meetings – excluding the period preceding the first meeting and the time following the last meeting we consider.<sup>24</sup>

**Table 4.1: Claimed essential patents filed before, during or after a meeting**

<i>Period (1)</i>	<i>Cumulative length in weeks (2)</i>	<i>Claimed essential patents with priority date within that period (3)</i>	<i>As (3), by participating firms, inventor(s) present at meeting (4)</i>	<i>As (3), by participating firms’ inventor(s) not present at meeting (5)</i>	<i>As (3), by non-participating firms (6)</i>
Pre-meeting	77.0	520 (6.8/week)	326 (4.2/week)	159 (2.1/week)	35 (0.5/week)
During meeting	51.3	204 (4.0/week)	95 (1.9/week)	69 (1.3/week)	40 (0.8/week)
Idle	452.9	1170 (2.6/week)	580 (1.3/week)	395 (0.9/week)	195 (0.4/week)
Total	581.1	1856 (3.2/week)	988 (1.7/week)	608 (1.0/week)	260 (0.5/week)

*Note: In a few cases, meetings were held very close together. As a consequence, a total of 38 claimed essential patents (that is 2.0 percent of all patents) overlapped by being both in a post-meeting and a pre-meeting period. In the calculation of the totals, we have removed the duplicates.*

Now we turn to the findings. As Column (3) in Table 4.1 shows, the patenting intensity in the ‘pre-meeting’ periods is much higher than in the idle period between meetings. Also the patenting intensity during the meetings is higher, but this effect is less pronounced. In order to gain a better understanding of why this effect occurs, we further broke these patent filings down into three categories: patents where one of the meeting participants is listed as inventor

<sup>24</sup> If we include these periods, our data would contain (among other things) some very valuable patents applied for long before the series of meetings, which could substantially bias our measurements.



(Column 4), patents filed by firms that participate in the meetings but where the inventors are not meeting participants ('colleagues back home', Column 5), and patents by firms not participating in the meetings at all. The effect is strongest for participants-inventors. During the pre-meeting period, their patenting intensity is over 3 times higher than in the idle periods. During the actual meeting period, it is 1.5 times higher. For the colleagues back home, both effects are less pronounced but still clearly present. Finally, for companies not participating in the meetings at all, we see another, interesting pattern (Column 6). The pre-meeting period hardly shows any rise in patenting activity at all. However, during the time the meeting takes place (which they are not attending) their patenting activity doubles. Table 4.2 is based on the same data as the previous table, but groups the filings of all participants together. The results suggest that we can accept both hypotheses: participating firms peak the week before a meeting, while non-participating firms peak during the meeting.

**Table 4.2: Claimed essential patents filed before, during or after a meeting (grouped together)**

<i>Period (1)</i>	<i>Claimed essential patents by participating firms with priority date within that period (2)</i>	<i>Claimed essential patents by non-participating firms with priority date within that period (3)</i>
Pre-meeting	487 (6.3/week)	35 (0.5/week)
During meeting	164 (3.2/week)	40 (0.8/week)
Idle	975 (2.2/week)	195 (0.4/week)
Total	1626 (2.8/week)	260 (0.5/week)

*As previously noted, 38 claimed essential patents overlapped by being both in a post-meeting and a pre-meeting period. In the calculation of the totals, we have removed the duplicates.*

Now turning to Hypothesis H1 (“*There is an increased intensity in essential patent filing just before and during a standardization meeting*”), we do indeed observe a sizable phenomenon, and thus accept this proposition. In addition, we observe two different *types* of increased intensity: the meeting participants show a significant peak in filing in the 7 days before a standardization meeting, whereas non-participants show a (smaller but still notable) peak that occurs *during* the standardization meeting.

#### 4.4.2 Testing the second hypothesis: Does meeting participation increase likelihood of patent inclusion?

As argued before, standardization meetings offer opportunities to their participants to ‘position their patents in the standards’. That is, by making technical submissions that are covered by their own patents, by proposing their patented technologies at the meeting, and by bargaining with other participants about the content of the standard, they can attempt to have the final standard covering their own patents.

So, how effective are meeting participants in having their patented technology included in the standard? This question is the core of Hypothesis 2. To address this question, we constructed a dataset of *all* US patents and patent applications by inventors who were identified as having participated at one or more of the 3GPP meetings under consideration. We restricted this search to the years 1999 to 2010, the period in which our studied meetings took place. We considered the resulting 14,524 patents as a ‘pool’ of patents that are *potentially* essential to the 3GPP standard. In this respect, this dataset differs from the one we used in the previous section, which included (disclosed) essential patents only. Then, we studied the determinants of whether such a patent is disclosed by its owner to be a standard essential patent, using the earlier mentioned Open Essential IPR Disclosure Database (OEIDD).

Table 4.3 reports our findings. In these LOGIT regressions, the dependent variables are whether or not a patent has been disclosed as essential. Model 1 tests the two core hypotheses; since a single patent can only be applied for either in the pre-meeting period or during the meeting (and never at *both*), we can enter both variables at once, without being concerned about any effect they might have on each other. For patents applied for just before a standardization meeting, we see a significant and strong positive effect. We also added a number of control variables to test how robust this effect is. Since it might be argued that patents with a higher technical merit or ‘value’ are more likely to be essential, we included in Model 2 the number of received forward citations of the patent in question, excluding self-citations. While this effect in itself is found to be significant (as expected, in line with the earlier findings of Rysman and Simcoe, 2008), it does not affect our

core hypothesis at all – it is really an independent effect. Since companies with a large patent stock may have different strategies than those with a small patent portfolio, we included in Model 3 the total patent stock of the assignee. In Model 4 we did the same for the stock of declared essential patents only. Again here, both effects are significant yet also do not affect our core hypothesis.

**Table 4.3: Determinants of patent essentiality**

	Model 1	Model 2	Model 3	Model 4
Patent filed during pre-meeting period	0.5301 [7.32]***	0.5236 [7.19]***	0.5236 [7.19]***	0.5388 [7.28]***
Patent filed during meeting period	0.0354 [0.31]	0.0337 [0.29]	0.0333 [0.29]	0.0681 [0.59]
Forward citations (no self-citations)		0.0181 [8.49]***	0.0181 [8.48]***	0.0164 [7.41]***
Patent stock of assignee (Log10)			-0.0081 [-0.12]	0.1864 [2.48]**
Stock of essential patents of assignee				0.0079 [17.39]***
Constant	-2.7672 [-64.06]***	-2.8247 [-63.99]***	-2.7922 [-9.91]***	-4.5271 [-13.94]***
N	14524	14524	14524	14524

\* p<0.1, \*\* p<0.05, \*\*\* p<0.01

However, the above is not true for patents that are filed during a standardization meeting (the second row in Table 4.3). Here we find no significant effect, and this remains the same after adding all the control variables.

Turning now to Hypothesis H2 (*Patents applied just before or during a standardization meeting have an increased likelihood to become essential patents*), we can only partly accept this proposition: patents applied *just before* a standardization meeting indeed have an increased likelihood to become essential patents, and this effect remains remarkably robust after adding several relevant control variables. However, patents applied *during* a standardization meeting do *not* have an increased likelihood of becoming essential patents.

#### 4.4.3 Testing the third hypothesis: Does the technical merit of just-in-time patents differ from other patents?

One important question now would be whether these just-in-time patents are any different from ‘normal’ patents, whose timing is not specifically linked to a standardization meeting. In particular, we are interested in whether they are cited equally often as other claimed essential patents. We used forward citations as a proxy of the technological importance of a patent (Carpenter et al., 1981; Trajtenberg, 1990; Karki, 1997). The interpretation is relatively straightforward: an invention with great technological impact will attract attention to the following inventions. Hence, technologically important patents will have more citations than less important patents. While there have been long discussions on how good citations are as a predictor of the *value* of a patent (see, among others, Gambardella, 2008), we believe they are much more a direct indicator of technologically important patents, or ‘technical merit’, which is what this paper is studying. To obtain a reliable citation performance measurement, it is important to consider the distribution of incoming citations over time. Rysman and Simcoe (2008) have shown that for claimed essential patents, this citation tail is longer than otherwise identical non-essential patents. Therefore it is important to ensure that the patents we include in this analysis had sufficient time to collect incoming citations. With this in mind, we selected all claimed essential patents or patent applications in our dataset with a priority date of 2005 or earlier (slightly over 1000 patents in our dataset meet that criterion). Using patent citation data compiled in 2012, we see that all these patents had at least 7 years to collect citations. Even the most recent patents in this selection are well into their citation tail, reassuring us that our citation score is robust.<sup>25</sup> Including too recent patents would make the analysis more prone to error and bias. Note that our set of selected patents does not include patents with a priority date older than 1999, the year in which the first of our 77 studied standardization meetings took place. This is important because earlier papers have observed that claimed essential patents preceding the

---

<sup>25</sup> Rysman and Simcoe (2008) estimate the citation tail on the basis of age since patent *grant*. At an age of 4 years, an average essential patent has already collected 40 percent of all the citations it will receive over its lifetime. If we assume that the priority date of a patent lies 3 years before the grant date, this 40 percent is reached 7 years after the priority date.

standardization effort often have a much higher citation score, being selected for their technological contribution, even though they are ‘old’ (Bekkers et al., 2011). Excluding this group prevents unwanted bias in this respect. Finally, while the following analysis includes all citations, we also performed the same analysis with self-citations removed. The outcomes are similar. Also when we performed the analysis using earlier cut-off dates, we got similar results, suggesting that the citation score measurement is robust and not impacted by truncation biases.

Within our selection, older patents had more opportunities to collect citations than younger patents. To correct for this, we followed the approach suggested by Jaffe & Trajtenberg (2002). For each priority year in our dataset, we calculated the average citation performance of all non-essential patents in the appropriate technology classes.<sup>26</sup> Any essential patent score can thus be compared to the average citation score in that year. Since all our patents are in a relatively narrow set of technology classes displaying rather similar citation performance, there was no need for a technology class correction. While we took the citation performance of non-essential patents as a base reference point, all our conclusions are based on comparing different types of essential patents, avoiding the earlier mentioned problems of endogeneity.

Figure 4.2 shows the main results of our analysis. The bars in this graph represent the citation performance of claimed essential patents for the three time periods defined earlier in this paper. Firstly, we observe that all the scores are higher than one. In other words, claimed essential patents have a higher citation performance than non-essential patents. This finding is in line with nearly every other study in this field. We could argue that this higher score may be the result of endogeneity rather than reflect a higher patent value; however, this question is irrelevant for our analysis since our aim is to compare groups of claimed essential patents, not compare claimed essential patents with non-essential patents. Secondly, we observe that claimed essential patents by inventor-participants applied for in the ‘pre-meeting’ period have a much lower citation performance than the (larger) group of patents in the ‘idle’ period. Our observations were similar for the period during the meeting. We expect, however, that the performance score for

---

<sup>26</sup> In the interest of computation time, we did not take the full population of non-essential patents but a large sample (around 10,000 patents, i.e. 10 times the number of essential patents in the selection).

inventors not participating in the meetings would not be dependent on timing. Indeed, Figure 4.2 shows this is not the case. Thirdly, we see that the average citation score of inventor-participants is higher than that of other inventors of claimed essential patents. This can perhaps be understood from the disclosure rules in standardization settings. These rules typically state that disclosure is mandatory for known essential patents.<sup>27</sup> In our context, the qualifier ‘known’ is an important one: if the meeting participant is the inventor of a patent, it is apparent that he or she ‘knows’ about the patent. As the patents by inventor-participants had to be disclosed, they arguably had a better dissemination than other patents.

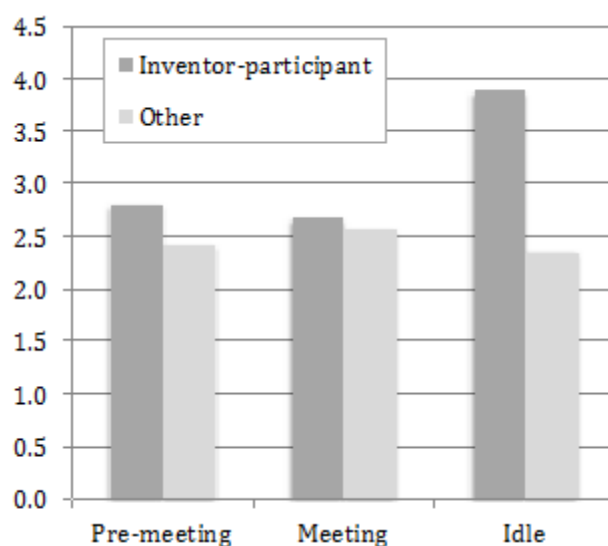

**Figure 4.2: Citation performance of claimed essential patents for three different periods.**

On the basis of these findings, we can firmly accept Hypothesis H3 (*‘Standard essential patents applied for just before or during a standardization meeting have a lower technical quality than comparable patents’*). Both claimed essential patents applied for by inventor-participants in the week preceding a standardization meeting, as well as patents applied for during the meeting, have a significantly lower citation performance than claimed essential patents by

---

<sup>27</sup> For details on SSO IPR policies, see Bekkers, R., & Updegrave, A. (2012). While 3GPP has no IPR rules, its members need to satisfy the IPR rules of the partnering organization(s) via which they gained access to the 3GPP meetings. Most 3GPP participants are ETSI members and the ETSI policy has a ‘known patents’ clause.

inventor-participants applied for at any other time.

#### 4.4.4 Explorative analysis: Who employs just-in-time strategies?

Considering the above, we need to pose the following questions: which organizations engage in just-in-time patenting in standards and do all meeting participants act in the same way, or are there differences between specific types of companies? In this section we address these questions by studying the determinants of just-in-time behavior, adopting a more explorative approach. For the patents and their filing moment, we used the same data as for hypotheses H1 and H3. Then, we identified the companies owning these patents (or, more precisely, the companies that submitted a disclosure that they believed to own an essential patent), and complemented our data with specific information on those companies. (A full description of the data and variables is included as Annex A.) Firstly, we determined the business model that best characterizes the company (in the context of the industry we were considering). While our original data distinguished nine distinct business models,<sup>28</sup> our analysis here reduces that into companies with or without an upstream business model (in the knowledge or product market). Secondly, we determined from which world region these companies originate – typically taking the region where the firm’s headquarters are based. Thirdly, we identified what we call ‘incumbent suppliers’. These are the manufacturing companies that championed the preceding technology standard (2G GSM, which was in many ways also the institutional predecessor of 3GPP). This calculation was based on 1998 ETSI voting powers, which reflect the revenues of those companies in the mobile telecommunications market before W-CDMA or LTE equipment came on the market (see Annex A for the calculations). Then we considered companies’ total patent stock (for any technology area) as well as their patent stock relevant to the 3GPP standards we are examining. Finally, we included the intensity of participation in the 3GPP meetings.

---

<sup>28</sup> These are: (1) Pure upstream knowledge developer or patent holding company (excl. universities); (2) Universities / public research institutes / states; (3) Component suppliers (incl. semiconductors); (4) Software and software-based services, (5) Equipment suppliers, product vendors, system integrators, (6) Service providers (telecommunications, radio, television, etc.), (7) SSOs, fora and consortia, technology promoters (as patent owners themselves), (8) Individual patent owner, (9) Measurement and instruments, testing system.

Before turning to the results, we must stress that due to the nature of this data, it is inevitable that some of the above variables are related (see Annex B for a correlation matrix). Most upstream companies in our dataset, for instance, originate from the US. Most incumbent suppliers, in contrast, originate from Europe (the ‘GSM champions’). The South Korean companies in our dataset have a much higher than average overall patent stock (most of them are in a large business conglomerate known as Chaebol), whereas Japanese companies on average have a much lower stock of SEPs. In the interpretation of our analysis below, we will pay due respect to these interdependencies. Nevertheless, we feel it is valuable to present this combined analysis, as it provides insight into which type of companies embrace certain patenting strategies.

Our results are presented in Table 4.4, which shows the determinants of a patent strategy where filings are done in the 7 days preceding a standardization meeting. (We also performed the same analysis for filings done during the meeting, but omitted these from this paper as this strategy was found to be less pertinent in the sections above). In Model 1, we started looking at business models. We found that companies with an upstream business model are less likely to display this type of patent strategy. In Model 2, we considered the home country of these companies. With the baseline value in this model being Europe, we see that American companies are less likely to be involved in such strategies than European companies. The same is true for Japanese, Chinese and Canadian firms. In fact, this behavior is especially found among European and South Korean firms. In Model 3 we entered both business model and home base. Given the fact mentioned above that upstream business models are especially found in the US, it comes as no surprise that the significance of US home base completely disappears, while the other significant geographical relations remain.



**Table 4.4: Determinants of filing patents in the 7 days preceding a standardization meeting**

	Model 1	Model 2	Model 3	Model 4	Model 5	Model 6	Model 7	Model 8	Model 9
Upstream business	-0.2044		-0.2119		-0.2118		-0.3507		-0.3361
model	[-4.88]***		[-2.81]***		[-2.81]***		[-4.19]***		[-3.99]***
US <sup>(a)</sup>		-0.2795	-0.1069		-0.106		-0.2808		-0.3268
		[-4.91]***	[-1.28]		[-1.13]		[-2.51]**		[-2.83]***
KR		-0.083	-0.0764		-0.0754		-0.1603		-0.2066
		[-1.32]	[-1.21]		[-0.98]		[-1.50]		[-1.87]*
JP		-0.1751	-0.1826		-0.1816		0.0836		-0.0003
		[-2.66]***	[-2.77]***		[-2.28]**		[0.86]		[-0.00]
CN		-0.2925	-0.2895		-0.2885		-0.0733		-0.0774
		[-2.09]**	[-2.07]**		[-1.96]**		[-0.47]		[-0.50]
CA		-0.3344	-0.3418		-0.3416		-0.3061		-0.2667
		[-3.01]***	[-3.08]***		[-3.07]***		[-2.73]***		[-2.34]**
Incumbent				0.1408	0.0019		-0.0325		-0.093
suppliers				[2.24]**	[0.02]		[-0.37]		[-0.98]
Total patent stock						0.0116	-0.2351		-0.2257
(Log10)						[0.28]	[-3.73]***		[-3.55]***
3GPP SEP stock						0.0108	0.1975		0.1732
(log10)						[0.59]	[5.11]***		[4.20]***
3GPP participation								0.0026	0.0024
intensity								[2.45]**	[1.75]*
Constant	-1.1236	-1.0191	-1.0117	-1.2083	-1.0127	-1.2562	-0.2926	-1.4287	-0.4748
	[-46.83]***	[-21.82]***	[-21.63]***	[-58.06]***	[-15.66]***	[-7.54]***	[-1.30]	[-14.52]***	[-1.90]*
Observations	14524	14524	14524	14524	14524	14524	14524	14524	14524

(a): For all the geographical dummies, the baseline value is home base in Europe.

In Model 4, we considered the effect of being an incumbent supplier. It is a positive, significant effect: the firms that dominated the GSM market (Nokia, Ericsson, Alcatel, Siemens, and others) show this strategic patenting behavior more than other firms. Arguably, they are vetted in the standardization game. Combining this incumbent supplier variable with earlier data (Model 5), we again

see an expected interdependence, as most of these incumbent forms are in fact European.<sup>29</sup>

Looking at patent stock gives interesting results. While these two variables do not seem to do much themselves (Model 6), their significance becomes visible if also controlled for countries (Model 7). Interestingly, companies with a large overall patent portfolio show *less* of this strategic behavior, whereas companies with large portfolios specific for the standards we are studying, show *more* of it. Finally, intensity of participation in 3GPP meetings displays a positive effect on this strategic behavior, which remains stable after adding all other variables.

Summarizing, we found that a strategy of applying for patents in the 7 days preceding a standardization meeting is employed by: 1) vertically integrated firms (hence less by US firms, which are mostly upstream firms), 2) the incumbent champions of the previous technology standard (hence more by European firms, where these champions are found), 3) smaller companies that nevertheless have large SEP portfolios for the standard (e.g. very dedicated companies) and, finally and not surprisingly, 4) companies that are very actively participating in 3GPP meetings.

#### 4.5. Conclusions and discussion

The main **findings** of this study can be summarized as follows:

- (1) In the seven days preceding a standardization meeting, we observe a large peak in (preliminary) filing of patents that eventually become essential. This effect can be mainly attributed to filings of which the inventors are also meeting participants. Non-participants show a (smaller) peak, which occurs *during* the standardization meeting.
- (2) Patents applied for in the period seven days *preceding* a standardization meeting have an increased likelihood to become essential patents, an effect that remains remarkably stable after

---

<sup>29</sup> Note that this effect is somewhat harder to see from the regression results, as Europe is the baseline value for the geographic dummies.

checking other possible explanations. In contrast, patents applied for *during* a standardization meeting are not more likely to become essential patents.

- (3) Essential patents filed by participants in the period seven days before a standardization meetings have a significantly lower citation score than other essential patents. The same is true for essential patents filed during a standardization meeting.
- (4) The strategy of applying for patents in the seven days preceding a standardization meeting is particularly employed by: 1) vertically integrated firms (hence less by US firms, which are mostly upstream firms), 2) the incumbent champions of the previous technology standard (hence more by European firms, where these champions are found), 3) smaller companies that nevertheless have large SEP portfolios for the standard and, finally 4) companies that are very actively participating in 3GPP meetings.

Our **interpretation of the above findings** is as follows: Just-in-time patenting consists of two different strategies. Firms that send participants to meetings are often engaged in what we call an *anticipatory patent filing strategy*, where they file (preliminary) patent applications just before a standardization meeting is held. After filing for these patents, they submit their ideas as (electronic) contributions and go to the meeting trying to get their contributions included in the standard. Indeed, these attempts do result in a higher likelihood of their patented technology becoming essential. However, patents filed using this strategy receive significantly fewer citations than the average essential patent, which probably reflects their lower technical merit.

Firms that do not send delegates to meetings are often engaged in what we call a *combinatory patent filing strategy*, where companies are able to take notice of the submitted technical proposals and ideas of others - which are published electronically - and then file new (preliminary) patent applications by recombining such ideas. In fact, we have found anecdotal evidence of patent examiners receiving no fewer than four identical preliminary patent filings from different firms on the same day, presumably about a technical idea that was shared in the context of a

standardization meeting. Such filing conduct is possible because, for the timeframe we consider, contributions and other information shared in the context of the standardization process were *not* considered to count as prior art in the patent examination process. However, since companies following this strategy did not attend the meeting, they were not able to bargain their technology for inclusion, and hence this group of patents has no greater likelihood of becoming an essential patent than the ‘average’ patent. Also patents filed using this *combinatory patent filing* strategy receive significantly fewer citations than the average essential patent, again probably reflecting their lower technical merit.

We believe our findings have a number of **implications**. First of all, if you believe that standards should only cover patented technology if that technology actually brings technical merit to the standard, then our observed just-in-time patenting behavior should raise concerns. As explained above, we observe that both types of just-in-time patents have a significantly lower technical merit than other essential patents. The inclusion of such patents may result in a range of effects that are relevant to policy makers, competition authorities, standards implementers and end users alike. It may result in higher prices (when the rents are passed on to end users), higher barriers to entry for implementers that do not own patents themselves, and affect the level of competition in the market. It may increase risks such as non-availability of essential patents. Finally, a wider proliferation of essential patents can also increase the risk of patent hold-up: The situation where once the patent is covered by the standard, and implements are locked in, the patent holder charges a higher licensing fee than it could have bargained before the technology was made part of the standard (e.g. *ex ante*). In such a situation, the patent holder not only charges rent for the technical merit of the patent, it also appropriates itself the (high) switching costs of the implementers. Patent hold-up can overcompensate patentees, raise prices for consumers who lose the benefit of competition among technologies, and deter innovation by manufacturers facing the risk of hold-up (FTC, 2011).

On the basis of these implications, SSOs could be recommended to take a critical look at the patent inclusion process, and reconsider whether just-in-time patenting strategies drive an unnecessary high degree of low merit patents into their standard. Furthermore, we believe the implications are also relevant to patent offices. Recently, the EPO has begun cooperating with standard setting

bodies in order to include technical submissions and other information shared in the standardization context as prior art (Willingmyre, 2012). We believe this is a very significant step in preventing some of the negative effects of the phenomenon we observe, and would welcome other patent offices to take similar steps. Finally, given the high societal importance of open standards, we believe these implications are relevant for policy makers and competition/antitrust authorities, for reasons already stated above.

Finally, we would like to point out that our study also has **limitations**. First of all, our observations are based on one standardization effort only, the development of 3GPP's W-CDMA and LTE standard. Although this is an economically very significant standardization effort, offering good availability of data for our analyses, its findings are not necessarily generalizable to other standard setting efforts. Across SSOs, and across technology areas in a broader sense, there may be differences in SSOs and meeting rules, in culture, and in strategic conduct. While we expect the results for the IEEE wireless LAN standards to be more like those in our study than, say, the results for IETF standards, we have not studied them. Future research could investigate to what degree standardization in other areas and organizations is similar or different. A second limitation of our study is that our observation of standard essential patents is based on disclosures by the patent owners, and might be prone to both over declaration (companies declaring patents as SEPs while they are not) and under disclosure (companies that fail to declare SEPs). Databases of disclosed patents may also have some other forms of bias, such as those discussed in Bekkers & Updegrove (2012). While we are aware of this limitation, there are no real alternatives for a study like this. The ultimate test of essentiality, known as a 'claim chart' that compares each claim in the patent with the relevant clauses in the standard in question, is a very specialist and expensive exercise, especially if it has to be performed for a large set of patents. A third limitation we would like to mention is specifically relevant to Section 4.4.2 of this paper, relating to the set of all patents by inventors who have also participated in 3GPP meetings. While we consider this set to be the 'pool' of potentially essential patents, we cannot determine whether some of these inventors started to work on other areas. Having said that, we restricted this set of patents to the period 1999-2010 (when our studied meetings took place) and expect any possible bias to be small.

## Appendix A: Overview of variables for regression in Section 3.4.4

---

<b>Business model</b>	Upstream business model	A firm's business model is one of the following: (1) Pure upstream knowledge developer or patent holding company (excl. universities); (2) Universities / public research institutes / states; (3) Component suppliers (incl. semiconductors); (4) Software and software-based services.
<b>Geographical</b>	US	Home base is the United States. <i>Note: for all the geographical dummies, the baseline value is home base in Europe.</i>
	KR	Home base is South Korea
	JP	Home base is Japan
	CN	Home base is China
	CA	Home base is Canada
<b>Incumbent suppliers</b>	Incumbent suppliers	Company is full ETSI 'manufacturer' member and has voting power of 18 or more in ETSI per January 1998 (this is the case for 6 out of the total of 31 ETSI 'manufacturer' member companies; note however that not all companies in our overall data set are or were ETSI members at that time.
<b>Patent stock</b>	Total patent stock (log10)	The log10 of the total number of patent families owned by that firm, as determined by the Thomson Reuters Derwent Innovation Index.
	3GPP SEP stock (log10)	The log10 of the total number of USPTO and EPO patents declared essential to the 3GPP W-CDMA and LTE standards, based on the OEIDD database.
<b>Intensity of participation</b>	3GPP participation intensity	Percentage of the 3GPP meetings actually attended by the firm.

---

## Appendix B: Overview of correlations between variables in regression of Section

### 3.4.4

	(1)	(2)	(3)	(4)	(5)	(6)	(7)	(8)	(9)	(10)
(1) Upstream business model	1									
(2) US	-0.2894	1								
(3) KR	-0.3037	-0.2226	1							
(4) JP	-0.3444	-0.2027	-0.2378	1						
(5) CN	-0.0982	-0.0678	-0.0796	-0.0725	1					
(6) CA	-0.1542	-0.0907	-0.1065	-0.0969	-0.0324	1				
(7) Incumbent suppliers	-0.2459	0.6148	-0.1727	-0.1573	-0.0526	0.2252	1			
(8) Total patent stock (Log10)	-0.441	-0.2871	0.5365	0.2599	0.089	-0.134	-0.1137	1		
(9) 3GPP SEP stock (log10)	0.5341	-0.2779	0.3058	-0.6267	-0.167	-0.1756	-0.1571	0.0451	1	
(10) 3GPP participation intensity	0.1641	-0.2093	0.1521	0.0429	-0.2254	-0.3122	0.0244	0.1772	0.4195	1

*Note: Due to the large number of observations (over 14,000), almost all correlations are statistically significant at the 1% level.*

## Chapter 5: The role of essential patents as knowledge input for future R&D

### 5.1. Introduction

Essential patents attract much attention because of their unique nature (Bekkers et al., 2002; Rysman et al., 2008; Bekkers et al., 2009; Simcoe et al., 2009; Bekkers et al., 2011; Layne-Farrar, 2011; Kang et al., 2012; Kang et al., 2013a). The essential patent concept is well defined by European Telecommunications Standards Institute (ETSI) as follows (ETSI, 2013).

*"ESSENTIAL" as applied to IPR means that it is not possible on technical (but not commercial) grounds, taking into account normal technical practice and the state of the art generally available at the time of standardization, to make, sell, lease, otherwise dispose of, repair, use or operate EQUIPMENT or METHODS which comply with a STANDARD without infringing that IPR. For the avoidance of doubt in exceptional cases where a STANDARD can only be implemented by technical solutions, all of which are infringements of IPRs, all such IPRs shall be considered ESSENTIAL.*

In short, if technologies to implement the standard are legally protected by patents, the patents are called essential patents. As an intellectual property right, essential patents are important assets for their right holders. Simultaneously, essential patents are component technologies of standards. Accordingly, any firm that wants to implement a standard must get a license from the essential patent owner.

The benefits of owning essential patents go without saying. Most of all, licensing agreement with the owner(s) of essential patents is a must if one company implements technical standards. Implementing technical standards without an agreement is infringement of essential patents. Although SSOs ask essential patent owners to respect fair, reasonable, and non-discriminatory (FRAND) conditions, the definition of FRAND conditions is ambiguous (Lemley et al., 2007). The ambiguous



definition has led to many lawsuits between large companies in the mobile communications industry. Given the potential windfall of such intellectual property, many companies whose business is not strictly related to mobile communications technology often try to obtain essential patents.

A firm's patent becomes essential when it is added as a component technology of a particular standard. However, mostly many companies make their patents become essential patents by participating in standardization. There are strategies to make a company's own technological proposals (that are mostly patented) accepted in a technical standard and become essential. Invention of advanced technology is one of the strategies (Rysman et al, 2008). Active participation in the standardization is also an important strategy. Comparing the influence between the technological advancement within a patent and the active participation of the patent owner, Bekkers et al. (2011) found that the latter is more influential than the former to have a company's patent be essential in the standard. Along with active participation in the standardization, a company's alliances with other companies outside the standardization (Leiponen, 2008) and inventors' active participations to the standardization (Kang et al., 2012) are also effective to own essential patents. A recent surprising study showed that firms use an opportunistic patent filing pattern that they file first and bargain their technologies at the standardization meetings (Kang et al., 2013a). Existing literature indicates that firms make great efforts to get essential patents by participating in standardization.

A goal of a technical standard is to stimulate innovations by establishing common technology bases to compete (Blind et al., 2010). Do firms participate in the standardization so as to create a technology base that encourages innovation? Or, do they participate in the standardization to get essential patents? Despite a lot of prior studies, the question still remains unanswered. This chapter focuses on the standardizing firms' R&D efforts based on the standard. If standardizing firms' R&D based on the standard is not active even after the standard is completed, then it can be concluded that firms are only interested in getting essential patents.

The structure of this chapter is as follows. The next section formulates hypotheses. Section 5.3 describes the data set used for this analysis. In Section 5.4, I discuss my analysis results and verify the hypotheses formulated in Section 5.3. Section 5.5 concludes with remarks on future research agenda and policy implications.

## 5.2. Hypotheses

This study conducts in-depth analyses based on Wideband Code Division Multiple Access (WCDMA) and Long Term Evolution (LTE). They are considered as the most successful 3G and 4G mobile communications standards. Both are standardized by Third Generation Partnership Project (3GPP) Radio Access Network (RAN) 1 group. By searching all the companies owning essential patents of WCDMA and LTE and participating in 3GPP RAN1 standardization, I found that those firms can be categorized into four business models: non-practicing entities (NPEs), chipset vendors, manufacturers, and service providers. Our business model classification is consistent with a classification by Open Essential IPR Disclosure Database (OEIDD) (Bekkers et al., 2012). This database is an essential patent database containing more than 40,000 intellectual property right (IPR) disclosures and commitment statements that were made public by IPR owners at main standardization bodies. In addition to essential patents, this database also provides business models of companies based on their primary activity or the dominant revenue sources. I confirmed that my classification of the firms is justified by that of OEIDD. I formulate hypotheses for each business model based on its R&D rooted in a technical standard.

### 5.2.1. Non-practicing entities

NPE stands for Non-Practicing Entities, and, by definition, includes universities and research institutes. In this chapter, I apply the definition of NPE as an entity which does not practice its patented inventions and whose main revenue source is the licensing royalty and/or selling of their own patents (Reitzig et al., 2007). Some may argue that an NPE's role in the innovation process of the mobile communications industry is not clear because they do not intend to implement their inventions. However, each component function used in products in the mobile communications industry is defined by technologies, many of which probably are protected by means of intellectual property rights. In this sense, an NPE's role in terms of division of labor is to create technologies that can at least potentially be commercialized. Therefore, although they do not have (physical) products, NPEs must be included in this study.

Based on this business model, it is required for NPEs to have economically valuable patents. It is their interest to obtain essential patents because any owner of essential patents can ask for the licensing royalties generated from the use of the related technical standards. Kang and Motohashi (2012) found that subsequent innovations for

standardization by manufacturers are based on their own technologies, regardless of whether they are essential patents. In contrast, those by NPEs are based on essential patents, regardless of whether they are their own patents. Creating core competence (Prahalad et al., 1990) is not in an NPE's interest because having core competence in specific technology fields does not necessarily indicate having economically important patents in those fields. They are less constrained in specific technologies than manufacturers. Rather, their interest is to have soon-to-be essential or might-be-infringed patents, from which they can earn licensing revenue. Accordingly, I derive the first hypothesis as follows:

*H1: Essential patents are an important knowledge source for an NPE's R&D.*

### 5.2.2. Chipset vendors

A chipset is a group of integrated circuits that are designed to work together. They are usually marketed as a single product. In the context of a mobile communications system, a chipset, or a part of a chipset, manages signal transmission/reception for communication, and its operation is defined by a mobile communications standard. Although the standard defines the operation, the implementation of the standard needs further R&D. For example, one must consider operation reliability, cost performance, implementation efficiency, etc. Therefore, it is important for the chipset vendors to conduct R&D based on the mobile communications standard. In this sense, a chipset vendors need to accumulate its own knowhow and skills that cannot be easily imitated by competing chipset vendors. Hence, it is likely that a chipset vendor's own patents are an important knowledge source.

Further, a chipset functions as a "brain" for end products such as mobile terminals and systems. Manufacturers of mobile terminals, base stations, system, etc. are the chipset vendors' customers. A chipset vendor is required to know what the demands of his customers are in order to attract them. Hence, the knowledge accumulated by others is also important for a chipset vendor's R&D. In total, I have the following hypotheses for chipset vendors:

*H2: Essential patents are an important knowledge source for a chipset vendor's R&D.*

### 5.2.3. Manufacturers

Chipset vendors and manufacturers can be classified into the same group in

terms of practicing their inventions. Both develop and market their products. In this sense, they are the opposite of the NPE. However, I need to separate chipset vendors and manufacturers from each other because they are different in terms of their positions in the supply chain. Manufacturers buy chipsets and other components to produce their products. Examples of manufacturers in this study are mobile terminal manufacturers and base station manufacturers. Although the manufacturers participate in the standardization process and obtain essential patents, their revenues are mainly from downstream markets which are not necessarily related to the technical standards. For example, they can manage revenues by optimizing supply chains, providing various services, and so on. In addition, as mentioned above, subsequent innovations for standardization by manufacturers are based on their own technologies, regardless of whether they are essential patents (Kang et al., 2012). Thus, essential patents as a knowledge source for manufacturers are not as critical as for NPEs and chipset vendors.

*H3: Essential patents as a knowledge source are not as important for manufacturers as for NPEs and chipset vendors.*

#### 5.2.4. Service providers

Service providers buy products from manufacturers and provide communications services. Although cost and performance of the products are important for them, they don't need to develop the technology for themselves. Hence, they have the least incentive to do R&D based on any type of patents compared to any other business models.

#### 5.2.5. Hypothesis summary

I summarize the hypotheses in Table 5.1 from the aforementioned discussion. For the comparison of R&D strategies in the following sections, the baseline value is service providers.

Table 5.1 Summary of Hypotheses:

The significance for each business model to conduct R&D based on each source

	<b>Reliance on essential patents as a R&amp;D knowledge source</b>
<b>NPE</b>	High
<b>Chipset vendors</b>	High
<b>Manufacturers (Followers)</b>	Medium (Medium)
<b>Service providers</b>	Low

### 5.3. Data and Analysis Model

#### 5.3.1. Data

It is necessary to make a proper data set for this study. The reason is that many big firms such as Nokia, Panasonic, Samsung Electronics, and so on have other business and R&D fields that are not related to mobile communications. This study uses PATSTAT (Ver. Oct, 2011), 3GPP RAN1 meeting minutes, ETSI Special Report 000314 (Ver. March 2012), and the Derwent Innovations Index. Table 5.2 shows each database and the retrieved information.

Table 5.2 Database and the Retrieved Information

<b>Database</b>	<b>Retrieved Information</b>
PATSTAT, Edition. Oct 2011.	Patent information (Application date, IPC, inventors, etc)
3GPP RAN1 Meeting minutes #1(21/1/99) ~ #60 (22/02/10)	Meeting participants list
ETSI Special Report 000314 Ver. Mar 2012	Essential patents list
Derwent Innovation Index	No. of patents assigned

First, I limit the patent data set to the patent applications filed by the firms which own essential patents. Then, I further limit the patent data set to patents filed to the U.S. Patent and Trademark Office (U.S. PTO). Patent applications are subject to a tradeoff between dominance and cost. Therefore, there is a bias in patent applications. The firms owning essential patents are doing business in global markets, but they also apply for patents in the U.S., taking on the risk of higher costs because of the U.S. market's global

significance. A more important reason is that patent applicants to the U.S. PTO must disclose prior art of an invention (duty of candor). Consequently, patent applications to the U.S. PTO result in numerous patent citations. I further limit the patent data set to patents filed after 1999, since the 3GPP RAN 1 standardization started in 1999. 3GPP is a standard setting organization which was formed in late 1990s to define a globally applicable mobile system after GSM. RAN1 is responsible for the specification of the physical layer of the radio interface, and defined W-CDMA and LTE since their inception.

Under the previously mentioned conditions, I construct the data set as follows. First, I retrieve the list of essential patents for W-CDMA and LTE from ETSI SR 000314 and find their international patent classifications (IPCs). Second, I extract the patent applications in the same IPCs. Third, I remove the essential patents and the patent applications “aimed” at essential patents. This is necessary because our interest is how important essential patents are as a knowledge source for future R&D. The patent applications aimed at essential patents are retrieved by taking out the list of patent applications by the participants of standardization meetings. The meeting participants are found from 3GPP RAN1 meeting minutes, and I consider that their patent applications are done with the intent of developing a standard rather than a firm’s business. Consequently, I obtain the patent data set for mobile communications, excluding those patents related to the mobile communications standards. I summarize the dataset construction process in Figure 5.1.

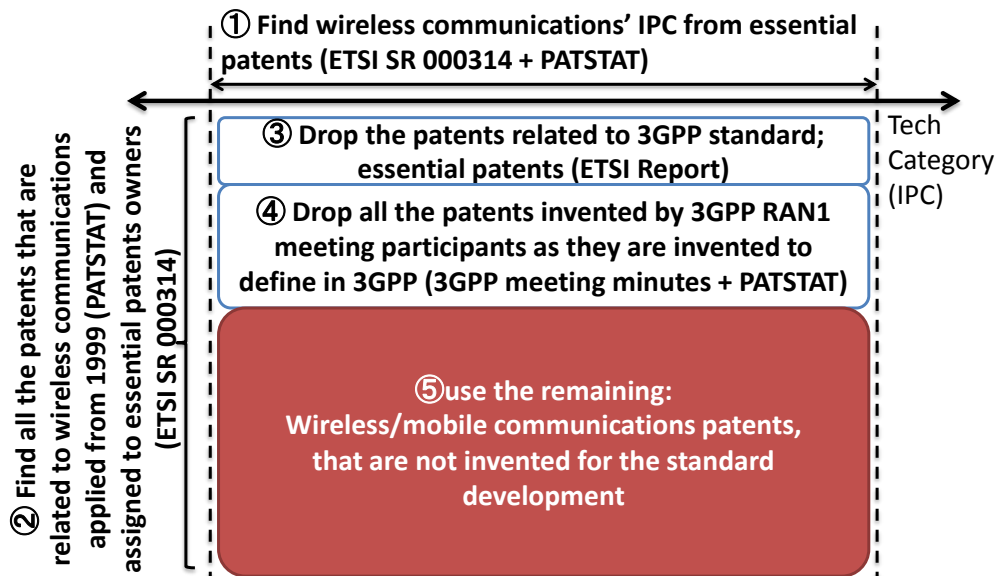

Figure 5.1 Dataset Construction

I obtained 28801 patent applications by 43 firms through the method aforementioned. Table 5.3 shows the data statistics. The first column represents the business models that are considered in this research. The second, the third, and the fourth columns are the number of patent applications, the number of firms in each business model, and the number of patent applications per firm, respectively. The fourth column is obtained by dividing the second column by the third. First, manufacturers are the largest entity in my dataset (31 firms). Second, among the 4 business models, I note that chipset vendors and manufactures perform many R&D activities. This is perhaps because they have products while the others (NPEs and the service providers) do not. The largest number of patent applications per firm is done by chipset vendors (1065.3 patents per firm). This exceeds that of manufacturers (768.1 patents per firm) by 50%. This finding infers that chipset vendors conduct a great deal of R&D activities in the field.

Table 5.3 Data Statistics

Business model	No. of patent applications	No. of firms	No. of patents applications per firm
NPE	436	5	87.2
Chipset vendor	4261	4	1065.3
Manufacturer	23810	31	768.1
Service Provider	294	3	98.0
<b>All</b>	<b>28801</b>	<b>43</b>	<b>669.8</b>

Figure 5.2 depicts the number of annual patent applications to the U.S. PTO. The number of annual patent applications is fairly constant until 2005, and it decreases after 2005. One explanation for this tendency is patent applications are published 18 months from the earliest filing date. A patent application is confidential to the patent office until its publication. Although it is possible to publish a patent application at the request of the applicant, such is rare. Thus, there might be uncounted patent applications that were not published. Another explanation is my using patent applications to U.S. PTO. There are more non-U.S. based firms in the data. Therefore, there might be uncounted patent applications to U.S. PTO which were applied to their home country's PTO as the first patent applications and therefore not listed in the U.S. PTO.

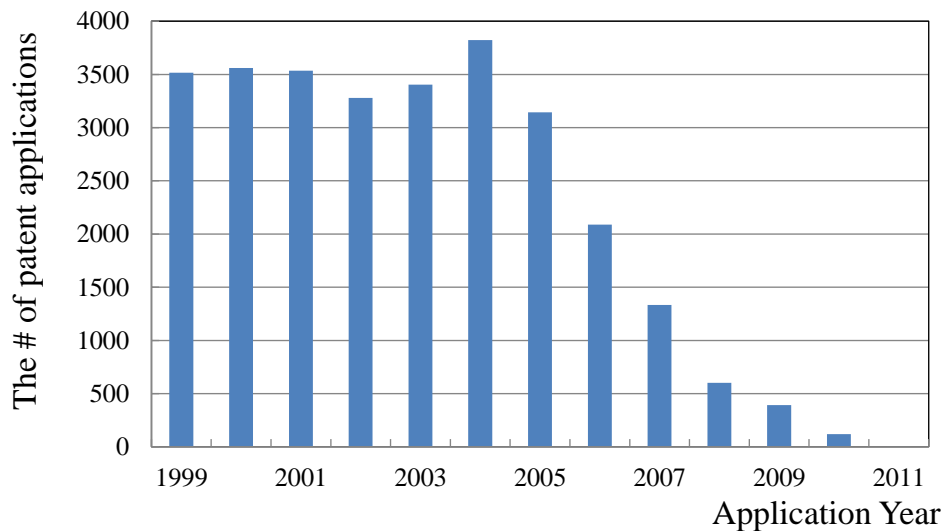

Figure 5.2 Number of annual patent applications (28801 patent applications)

### 5.3.2. Analysis model

My analysis uses a logit regression model. The observation is per patent



application. The dependent variable is a dummy variable and indicates whether a patent application cites essential patents (=1), or not (=0). To compare other knowledge source for R&D to essential patents, one additional logit regression models are used. The knowledge source to compare is internal knowledge. The dependent variable is a dummy variable and indicates whether a patent application cites any patents that were filed by the same applicants (=1), or not (=0). In patent applications, especially those to the U.S. PTO, an applicant must provide prior references, either patent or non-patent literature (duty of candour). Many studies have used patent citations as a proxy for knowledge flow (Trajtenberg et al., 1997; Nagaoka et al., 2010), and I develop analysis with this presumption.

The independent variables and the control variables are the same for the three regression models. The independent variables are dummy variables for each business model. In order to avoid the dummy variable trap (Greene, 2011), I do not define the dummy variable for service providers. I also define national dummies, and consider Chinese and Korean firms as following manufacturers. Accordingly, Asustek, HTC, Huawei, LG, Samsung Electronics, and ZTE are classified as followers in this study. Since they are all manufacturing firms, there must be inevitable correlations between independent variables (See Appendix A for a correlation matrix).

One may raise a concern about classification of followers. For example, Samsung Electronics is included as a follower. First, as seen in Figure 5.1, most data are patent applications before 2006. Thus, although some of the five firms from China and Korea are market leaders as of today (2013), they were not by mid-2000s. Second, even if Chinese and Korean firms increase their essential patents which may be an evidence of their competitiveness, their knowledge is still heavily dependent on the Triad (Kang et al., 2013b). Third, excluding them, the other firms are from Europe, Japan and the U.S. Since these countries have local mobile communication standards, their domestic firms developed relevant systems. For example, in 1990s, the second-generation (2G) communication standards were designed in different countries; global system for mobile communication (GSM) in Europe; interim standard-95 (IS-95), which is more well-recognized with its brand name, cdmaOne in North America; and personal digital cellular (PDC) in Japan. GSM was standardized as a result of the cooperation between competing companies under the policy of the European Commission to enlarge the size of European markets. The standardization of IS-95 was led by Qualcomm, and that of PDC was done by Nippon Telegraph and Telephone (NTT). Consequently, the firms in

those countries have constructed some level of technological capabilities, knowhow, and skills.

In order to properly control some critical influence, I include several control variables in the regression model. The first control variable is firm size. Companies with large patent portfolios have more resource to manage their corporate strategy by themselves. They don't need to rely on standards and have less incentive to participate in the standardization than companies with small patent portfolios (Blind et al., 2004). The amount of assigned patent applications is used as a proxy of the firm size, and can be obtained from the Derwent Innovation Index. The  $\log_{10}$  value is used in the regression. The second control variable is core technological competence. I use Relative Technology Advantage (RTA) as a proxy of the core technological competence (Narin et al, 1987; Patel et al, 1997). The RTA is obtained from the ratio of the number of a firm's patents in a technology field to the total number of the firm's patents in all technology fields. RTA is the technological competence in each technology field within a firm. Then, I calculated the RTA of each patent application in all member IPC subgroups and took the average. By adding this variable, I can control the influence of core competence to each patent application. The third control variable is absorptive capacity (Cohen et al, 1990). The absorptive capacity is important in R&D, especially when using external knowledge. With low absorptive capacity, a firm will fail in not only recognizing new information but also applying the information to commercialization. Many methodologies to measure the absorptive capacity (Cohen et al., 1990) have been proposed, and I use the number of inventors in this study (Veugelers, 1997). The fourth control variable is a dummy variable for the national origin of each firm. There are five countries in my data, and the national origin dummy variables are defined for China (including Taiwan), Europe, Japan, and Korea. The fifth control variable is the prior application year.

## **5.4. Results and Discussions**

### **5.4.1. Essential patents as a knowledge source**

The comparison of R&D strategies based on a standard is shown in Table 5.4 with the coefficients and t statistics of each variable. First, NPEs have positive effects and statistical significance at the 1% level in all regression models. This result indicates that an NPE's inventions are based on essential patents compared to service providers. Thus, H1 is supported. Second, chipset vendors also have positive effects and statistical significance at 1% level in all regression models. This result indicates that a chipset

vendor's inventions are based on essential patents. Thus, H2 is supported. On the other hand, manufacturers have a negative effect and statistical significance at the 1% level in regression model 3 while the coefficients are all positive in the other regression models. This must be interpreted that essential patents for manufacturers' R&D are not as important as those for NPEs and chipset vendors, but the importance of essential patents for manufacturers' R&D is larger than that for service providers. As assumed in Section 5.2.3, the mobile standard itself may not be of much interest for manufacturers. Further, the coefficient of following manufacturers is not consistent in models and is not statistical significant in any model, the significance of mobile standards in following manufacturers' R&D is not clear.

Table 5.4 Regression result 1  
DV: whether citing essential patents (= 1), or not (= 0)

	1	2	3	4	5	6	7	8	9
NPE	1.6382 [16.82]***				2.4949 [9.75]***	2.5487 [9.93]***	2.7526 [10.66]***	2.7697 [10.72]***	2.7733 [10.74]***
Chipset vendor		0.7036 [17.50]***			1.4724 [6.14]***	1.3946 [5.78]***	1.4277 [5.91]***	1.4355 [5.95]***	1.4379 [5.96]***
Manufacturer			-0.8006 [-21.20]***		0.9403 [4.02]***	0.8827 [3.76]***	0.9482 [4.04]***	0.9489 [4.04]***	0.9464 [4.03]***
Service Provider				-0.9141 [-3.94]***	.	.	.	.	.
China Dummy					-0.3168 [-2.07]**	-0.3939 [-2.54]**	-0.1955 [-1.25]	-0.1916 [-1.22]	-0.1805 [-1.14]
Japan Dummy					-0.7378 [-14.38]***	-0.8677 [-13.03]***	-0.983 [-14.52]***	-0.9819 [-14.51]***	-0.9822 [-14.51]***
Korea Dummy					0.0146 [0.26]	-0.1449 [-1.89]*	-0.2512 [-3.23]***	-0.2579 [-3.32]***	-0.2546 [-3.26]***
US Dummy					0.0153 [0.30]	-0.0021 [-0.04]	0.0051 [0.10]	-0.006 [-0.11]	-0.0076 [-0.14]
Log10(NumPat)						0.1619 [3.02]***	0.1451 [2.71]***	0.1452 [2.71]***	0.1468 [2.74]***
RTA							-0.2172 [-8.77]***	-0.2184 [-8.81]***	-0.2187 [-8.82]***
The Num of Inventors								0.0253 [2.50]**	0.0258 [2.54]**
Application Year	No	No	No	No	No	No	No	No	Yes
Constant	-1.7484 [-104.64]***	-1.8366 [-99.07]***	-1.0813 [-33.22]***	-1.7033 [-103.81]***	-2.6174 [-11.30]***	-3.1373 [-10.85]***	-2.9769 [-10.29]***	-3.0357 [-10.46]***	4.5053 [0.34]
N	28801	28801	28801	28801	28801	28801	28801	28801	28801

#### 5.4.2. Internal knowledge as a knowledge source

The comparison of R&D strategies based on a standard is shown in Table 5.5 with the coefficients and t statistics of each variable. In regression model 1, the

coefficient of NPEs is negative and statistically significant at 1 % in all regression models. This can be explained by InterDigital. Most data in NPEs are InterDigital's patent applications. InterDigital declares all its patents essential patents (Bekkers et al., 2009). As a result, NPEs have almost no self-citation. Second, the coefficient of chipset vendors is negative and statistically significant at 1% only in regression model 2. Nevertheless, chipset vendors don't have statistical significance in regression models 5~10. In contrast, manufacturers have positive effects with statistical significance at 1% in all regression models. This result indicates that manufacturers' inventions are based on their own technology. In addition, the tendency to invent based on one's own technology is more likely for following manufacturers. The coefficients of China and Korea dummies are negative and statistically significant at the 1% level in all regression models. This result must mean that Chinese and Korean firms do not have enough knowledge accumulation, and they rely on external knowledge rather than their own knowledge. This result is consistent with Kang et al. (2013b).

Table 5.5 Regression result 2

DV: whether citing patents filed by the same applicant (= 1), or not (= 0)  
(excluding essential patents in DV)

	1	2	3	4	5	6	7	8	9
NPE	-0.8857 [-7.84]***				-0.5256 [-3.07]***	-0.5 [-2.91]***	-0.5029 [-2.91]***	-0.463 [-2.68]***	-0.5051 [-2.92]***
Chipset vendor		-0.4301 [-12.37]***			-0.0198 [-0.15]	-0.0591 [-0.44]	-0.0595 [-0.44]	-0.0436 [-0.32]	-0.0743 [-0.55]
Manufacturer			0.4934 [15.06]***		0.3497 [2.78]***	0.321 [2.53]**	0.3198 [2.52]**	0.3205 [2.52]**	0.3482 [2.74]***
Service Provider				-0.4101 [-3.30]***					
China Dummy					-0.3316 [-3.02]***	-0.3789 [-3.37]***	-0.3825 [-3.37]***	-0.371 [-3.26]***	-0.5026 [-4.37]***
Japan Dummy					0.5446 [16.90]***	0.4792 [10.51]***	0.4811 [10.35]***	0.483 [10.38]***	0.4876 [10.45]***
Korea Dummy					-0.3915 [-9.07]***	-0.4717 [-8.05]***	-0.47 [-7.95]***	-0.4901 [-8.27]***	-0.5282 [-8.86]***
US Dummy					0.0613 [1.60]	0.0525 [1.36]	0.0522 [1.35]	0.0257 [0.66]	0.0469 [1.20]
Log10(NumPat)						0.0806 [2.02]**	0.0809 [2.03]**	0.0853 [2.14]**	0.0675 [1.69]*
RTA							0.0032 [0.21]	0.0011 [0.07]	0.0023 [0.15]
The Num of Inventors								0.0626 [8.33]***	0.0564 [7.47]***
Application Year	No	No	No	No	No	No	No	No	Yes
Constant	-0.2751 [-22.95]***	-0.2256 [-17.56]***	-0.6983 [-23.23]***	-0.283 [-23.65]***	-0.6931 [-5.60]***	-0.9509 [-5.35]***	-0.9536 [-5.35]***	-1.1138 [-6.21]***	-85.5904 [-8.85]***
N	28801	28801	28801	28801	28801	28801	28801	28801	28801

#### 5.4.3. Result summary

I determined which business model weighs which knowledge source for its own R&D. However, it is not certain whether the difference is statistically significant or not. The Kruskal-Wallis test is a t-test that is able to test N-groups ( $N > 2$ ) for non-parametric data (Kruskal et al, 1952), but there are some limits to the Kruskal-Wallis test (Chan et al, 1997). The Kruskal-Wallis test only indicates that at least one of the groups in the data is statistically different from the others, but does not indicate the statistical differences between each group pair. In addition, it does not specify which group is statistically different from the others. Thus, I apply the Wilcoxon-Mann-Whitney test (Mann et al, 1947) to each business model pair.

The results are shown in Tables 5.6-1, and 5.6-2. First, Table 5.6-1 indicates the Wilcoxon-Mann-Whitney test of R&D based on a standard. Each test pair shows

statistical difference. Therefore, comparing the results together with the regression results, the importance of essential patents for R&D of each business model can be listed in order as follows: NPE > chipset vendor > manufacturer (as well as following manufacturer) > service provider. Second, Table 5.6-2 indicates the Wilcoxon-Mann-Whitney test of R&D based on internal knowledge. A statistically significant difference was not observed in any pairs between manufacturer and chipset vendor, and between service providers and NPEs. Therefore, comparing the results together with the regression results, the importance of internal knowledge for R&D of each business model can be listed in order as follows: (following manufacturer >) manufacturer > chipset vendor, service provider > NPE.

Table 5.6-1 Wilcoxon-Mann-Whitney test: R&D based on a standard

	Observation	Rank sum	Expected	<b>z</b>	Prob >  z
NPE	436	1236763	1024164		
Chipset vendor	4261	9796490	10009089		
Combined	4697	11033253	11033253	10.314	0.0000
Chipset vendor	4261	65460103	59807396		
Manufacturer	23810	3.285.E+08	3.342.E+08		
Combined	28071	3.940.E+08	3.940.E+08	18.808	0.0000
Manufacturer	23810	2.872.E+08	2.870.E+08		
Service provider	294	3318926	3543435		
Combined	24104	2.905.E+08	2.905.E+08	3.236	0.0012

Table 5.6-2 Wilcoxon-Mann-Whitney test: R&D based on internal knowledge

	Observation	Rank sum	Expected	<b>z</b>	Prob >  z
Manufacturer	23810	3.400.E+08	3.340.E+08		
Chipset vendor	4261	5.437.E+07	5.981.E+07		
Combined	28071	3.940.E+08	3.940.E+08	13.000	0.0000
Chipset vendor	4261	9.712.E+06	9.707.E+06		
Service provider	294	664636	669732		
Combined	4555	1.038.E+07	1.038.E+07	0.285	0.7760
Service provider	294	1.135.E+05	1.075.E+05		
NPE	436	153282	159358		
Combined	730	2.668.E+05	2.668.E+05	2.806	0.0050

I summarize the result in Table 5.7. Comparing Table 5.1 and Table 5.7, my assumption on the importance of R&D based on a standard is the same. However, the others are different. I assumed that the importance of internal knowledge for chipset vendors and manufacturers was high while that for following manufacturers was low, however the results show the opposite. Also, the importance of R&D based on others' knowledge to chipset vendors turned out to be lower than expected. Finally, the importance of R&D based on others' knowledge to manufacturers turned out to be the same as for following manufacturers.

Table 5.7 Summary of the regression results:  
Each business model's reliance on knowledge source

	<b>Standard</b>	<b>Internal knowledge</b>
<b>NPE</b>	Very high	Low
<b>Chipset vendors</b>	High	Medium
<b>Manufacturers (Followers)</b>	Medium (Medium)	High (Very Low)
<b>Service providers</b>	Low	Medium

### 5.5. Conclusions and policy implications

This study examined the role of essential patents as a knowledge input for future R&D from the case of WCDMA and LTE. It divided the firms owning essential patents and participating in the standardization by their business model, and compared their R&D activities that are based on a technical standard and their internal knowledge. The findings are as follows:

(1) Essential patents are very important for NPEs' R&D compared to any other business models. I assume this is because licensing fees that are expected from the standard implementation and/or infringement constitute their revenue source. Their R&D effort is less than those of chipset vendors and manufacturers in terms of the number of patent applications. However, their subsequent R&D is a lot rooted in essential patents.

(2) Essential patents are also important for chipset vendors' R&D compared to manufacturers and service providers. Their R&D effort per firm measured by the number of patent applications per firm is the highest in my data. Since the operation of mobile communication in a chipset is defined by the technical standard, the chipset

vendors' R&D is conducted based on the essential patents.

(3) Essential patents are an important knowledge source for manufacturers' R&D compared to service providers, but not as important as for NPEs and chipset vendors. Manufacturers count 72% ( $= 31 / 43 * 100$ ) of all the firms owning essential patents and participating in the standardization in my data. They consider their internal knowledge as an important knowledge source for future R&D rather than essential patents. Then, a question remains the reason why so many manufacturers are participating in the standardization recognizing that essential patents, a proxy of a technical standard, are not a knowledge source for future R&D. I discuss on this question later in this section.

(4) Although the coefficient of NPEs is negative in Table 5.5 which sets service providers as a base, the result is believed as a result that InterDigital, who has the biggest share of NPEs' patent applications in my data, tends to declare all its patents essential patents. Therefore, no particular knowledge source was important for service providers' future R&D.

The findings provide several implications. First, a clear tendency was found for NPEs to do R&D activities based on the technical standard although their patent applications were less than that of practicing companies. Considering their revenue source, it is not in their interest to implement their own patented technologies. If their patents are related to the technical standard and other business models' patents, NPEs' patents might worsen patent thickets (Shapiro, 2001) and hold-up problems (Lemley et al., 2007). Since any technical standard has a significant role for the innovations of the industry where the network effect is strong, any delay in deployment of the technical standard must not be allowed.

Second, tension between firms may be increasing due to essential patents. For example, essential patents are very attracted especially for NPE whose main revenue source is licensing fee. NPEs generate many standard-based inventions to get soon-to-be-standard and/or might-be-infringed patents. Manufacturers have to get essential patents before NPEs get them. The tension led the situation where, despite great R&D efforts to obtain essential patents, manufacturers, who are the main implementers, do not conduct additional R&D on top of the standard. There might be different motivations for companies to get essential patents. One may want to have leverage over the standard which plays a key role for innovation in the industry (Shapiro



et al., 1999; Tasse, 2000), and another may want to block any other firm from privatizing the standard. Either motivation makes manufacturers get essential patents recognizing that essential patents, a proxy of a technical standard, are not a knowledge source for future R&D. In the end, the tension results in a waste of energy and resource, and increases the social costs which will be paid by customers.

Third, tension between firms may be also increasing due to non-essential patents. These patents often create the patent thickets and the holdup problems. As Table 5.3 shows, 83% ( $= 23810 / 28801 * 100$ ) of the patent applications in my data are filed by manufacturers. The recent patent wars have illustrated that it is important to have a good non-essential patent portfolio as well as a good essential patent portfolio.

Finally, this chapter offers implications for following countries such as China and Korea. A result of this chapter shows that Chinese and Korean companies' dependency on their own knowledge is very low. This implies that knowledge accumulation in China and Korea takes a long time and their knowledge still relies on external knowledge from leading countries. Although knowledge transfer plays a key role in closing the gap between leaders and followers (Jaffe et al., 1993), China and Korea need more efforts to nurture domestic knowledge competitiveness.

**Appendix A: Overview of correlations between independent variables in regressions**

	1.	2.	3.	4.	5.	6.	7.	8.	9.	10.	11.
1. NPE	1										
2. Chipset vendors	-0.0517	1									
3. manufacturers	-0.2708	-0.9101	1								
4. service providers	-0.0126	-0.0423	-0.2218	1							
5. China dummy	-0.0049	-0.01	0.0141	-0.012	1						
6. Japan dummy	-0.077	-0.2589	0.2844	-0.0631	-0.0735	1					
7. Korea dummy	-0.0456	-0.1532	0.1684	-0.0373	-0.0435	-0.2285	1				
8. U.S. dummy	0.1822	0.6107	-0.6135	-0.0682	-0.0795	-0.4171	-0.2469	1			
9. Log10(NumPat)	-0.2322	-0.1209	0.2278	-0.1488	0.0387	0.5098	0.433	-0.331	1		
10. RTA	0.1348	0.0391	-0.0781	-0.0078	0.1754	-0.2959	-0.1602	0.1807	-0.3102	1	
11. No. of inventors	-0.0189	0.0155	-0.0074	-0.0039	-0.0229	-0.0644	0.0287	0.0764	-0.0253	0.0264	1

## **Chapter 6: Asia's Rise in ICT Global Standardization: Empirical Analysis of Chinese and Korean Companies in Mobile Communications Standardization**

### **6.1. Introduction**

Technological catch-up in Asian developing countries, particularly Northeast Asian countries, has become visible in many areas. Scientific catch-up by China, Korea, and Taiwan was observed in the solar cell industry (Sakata et al., 2013). These countries compete against leading countries such as Germany, Japan, and the U.S. in emerging technology fields and learn from them in matured technology fields. Chinese efforts to catch up in the chemical, medical, and drug industries were also observed (Motohashi, 2008). An analysis of the Chinese patent database showed that a significant number of patent applications to the State Intellectual Property Office, i.e., the Chinese patent office, for chemical, medical, and drug industries were applied from within China: 50% for chemical technologies and slightly more than 60% for medical and drug technologies.

Along with other industries, China's and Korea's catch-up in the information and communication technology (ICT) industry is acknowledged (Lee et al., 2001; Lee et al., 2002; Mu et al., 2005; Fan, 2006; Gao et al., 2012; Kenny et al., 2013; Murphree et al., 2013). Nevertheless, not many studies compared the differences between the national standardization strategies of China and Korea from a catch-up strategy perspective. In addition, prior studies failed to discuss how their participation in global standardization is positioned in their catch-up strategy. When one discusses catch-up in an industry in which the network effect prevails, he/she must not forget that the standard plays a key role for innovation in the industry (Shapiro et al., 1999; Tasse, 2000). Because a standard in the ICT industry is considered a technological base, industry-wide market formation largely depends on the standard. Hence, even if a new entrant gained as much technological

capability as that of a leading firm, whether the entrant is capable of leading the industry without leverage over the standard is uncertain. This chapter shows how China's and Korea's standard strategies and their subsequent performances differ from each other. For the analysis, I focus on the case of Wideband CDMA (WCDMA) and Long Term Evolution (LTE), two of the most successful global standards in the mobile communications industry. Although my scope is limited to these standards, this chapter achieves an in-depth analysis.

The structure of this chapter is as follows. The next section reviews the historical background of the standard development of mobile communications in Korea and China, before their activities in ICT global standardization, to determine how these countries developed their technological capabilities. Section 6.3 explains the research data. Section 6.4 presents my data analyses and findings. Section 6.5 concludes with discussions and implications.

## **6.2. Before the Asian Rise in ICT Global Standardization: How China and Korea gained their technological capabilities**

I briefly review the history of how Korea and China obtained the technological capabilities necessary to actively participate in ICT global standardization activities. As studies indicated (Jaffe et al., 1993; He et al., 2006), knowledge transfer played a key role in closing the gap between leading companies and Chinese and Korean companies in the industry.

### **6.2.1. Case of Korea**

The rise of Korea in ICT global standardization started in the 1980s (Lee et al., 2002; Jho, 2007). Mobile communications services in Korea were launched in March 1984 through the founding of Korea Mobile Telecommunications Services Co. under the Korea Electricity and Telecommunication Corp. However, the domestic mobile communications industry in the 1980s was heavily dependent on foreign firms: the mobile communications standard adopted was Advanced Mobile Phone System (AMPS), an analog mobile communication standard developed by Bell Labs, and necessary equipment was imported from abroad.

Demand for mobile communications services rapidly grew in the 1990s. To meet the demand, mobile communications evolved from an analog to a digital

system. In adopting a digital mobile communication standard, two options led by two different ministries under the Korean government were available.

The first option, proposed by the Ministry of Commerce, Industry and Energy (MOCIE, now the Ministry of Trade, Industry and Energy) was the Global System for Mobile Communications (GSM) project. Because GSM was already deployed as the European-wide mobile communications standard in the 1980s, the stability of the GSM system was guaranteed and quick deployment in the Korean market was expected. Because technological capability was inadequate for developing a mobile communications protocol in Korea in the early 1990s, government officers and engineers sought partners. However, no incumbent GSM manufacturer agreed to transfer technology to develop the GSM system in Korea (Yoo et al., 2005), which meant full reliance on foreign technology. This phenomenon was critical in the Korean government's decision to decline the GSM project because of its belief that technology transfer was important for the growth of the country's technological competence. The Korean government learned the importance of knowledge transfer for national growth from its experience with the TDX development project and, in January 1982, launched the TDX development project at the Electronics and Telecommunication Research Institute (ETRI) with four domestic firms as manufacturers and suppliers of TDX switching equipment: Daewoo, Goldstar (now LG), Otelco, and Samsung. Each firm had international partner(s), that is, advisor(s), such as Alcatel, AT&T, and Ericsson (Larson, 1995; Chapuis et al., 2003).

The second option was proposed by the Ministry of Information and Communications (MIC), which advocated the Code Division Multiple Access (CDMA)-based technology by Qualcomm. Qualcomm offered full support to the Korean government's request for technology transfer, including access to Qualcomm's intellectual property and expertise (Mock, 2005). An agreement between Qualcomm and ETRI to start a joint development project in May 1991 enabled the parties to provide radio and network technologies, respectively.<sup>30</sup>

---

<sup>30</sup> Korea IT Times' interview with Hang-gu Bahk (Chairman and CEO of Soam System) titled, "Tracing 50 Years of Korea's Electronics Industry Development." Available from <http://www.koreaitimes.com/story/7816/tracing-50-years-korea%E2%80%99s-electronics-industry-development> (Last accessed 5th April 2013).

Throughout the collaboration with Qualcomm, ETRI contributed to the authorization and commercialization of Interim Standard 95 (IS-95) as the first CDMA-based standard in 1993. ETRI's contribution to the Korean industry was to further transfer the knowledge of mobile communication technology to domestic firms such as LG Information and Communications (now LG Electronics), Samsung Electronics, and others.

This technology transfer formed the technological base for Korean domestic companies to contribute to the ICT global standardization.

#### 6.2.2. Case of China

Similar to Korea, China also developed its technological base by heavily relying on technology transfer from abroad. China changed its policy only during the late 1970s and early 1980s, and opened its domestic market and embraced foreign companies. As a result, not only investments and imported products but also relevant technologies were simultaneously introduced. Policy makers attempted to take advantage of telecommunication technologies from abroad, that is, through technology transfer, knowledge diffusion, and innovation.

Since the first foreign direct investment (FDI) was approved to found Shanghai Bell in 1984, many other major foreign companies have entered the Chinese market in the form of joint ventures (JV). Examples include Beijing International Switching System Corporation (with Siemens), Tianjin NEC, Qingdao AT&T, Beijing Nokia Hangxing, Nanjing Ericsson, Jiangsu Fujitsu, and Guangdong Nortel (Mu et al., 2005). Consequently, the FDI trend changed from “goods dominated” to “JV dominated,” which resulted in technology transfer from foreign companies to these JVs. With governmental support, telecommunication products from the JVs were successfully installed in telecommunication networks in China, which in turn facilitated further knowledge diffusion across the entire country (Tan, 2002). For example, an indigenous digital switch HJD-04 was developed in 1991 through knowledge diffusion from Shanghai Bell's System-12. During the rapid growth of the mobile communications market throughout the 1990s, four indigenous Chinese companies emerged as major players in the country's promising industry: DaTang, Great Dragon, Huawei, and ZTE (Malerba et al., 2012).

The mobile communication market started in 1987 with the introduction of

analog mobile communication standards such as Total Access Communication System and Advanced Mobile Phone System (AMPS) by China Telecom, affiliated with the Ministry of Posts and Telecommunications. Along with reforms and restructurings in government ministries and state-owned service providers, the GSM system was introduced by China Unicom (jointly owned by the Ministry of Electronic Industry, the Ministry of Railways, and the Ministry of Electrical Power) and China Telecom in 1995. In April 1998, the Ministry of Information Industry (MII) was established and played the role of regulating the telecommunication industry. As a result, China Telecom was split into three business units: China Telecom (fixed-line), China Mobile (mobile), and China Satcom (satellite). China Mobile took over the GSM system from China Telecom. In January 2002, CDMA IS-95A was launched by China Unicom, which entered into a CDMA Intellectual Property Agreement with Qualcomm in 2000 (Yu et al., 2005). These Chinese telecommunication service providers continued to take advantage of the fast growing business market in China and further expanded their business abroad in the late 1990s, particularly to developing countries. Simultaneously, they enhanced their R&D technological capabilities and started to actively participate in international standardization.

The R&D capability in the Chinese telecommunication industry was greatly improved through the development of China's own mobile communication standard (Fan, 2006; Gao et al., 2012; Hui, 2013). In 1995, a mixed R&D group with researchers from the Research Academy of Post and Telecommunication (RAPT) and a company founded in the U.S. by two Chinese engineers, Chen Wei and Xu Guanhan, was formed to invent a new mobile communication standard, the Time Division Synchronous Code Division Multiple Access (TD-SCDMA), to bypass Qualcomm's IPR advantages in CDMA (Liu et al., 2009). With efforts from DaTang, which was affiliated with MII, the International Telecommunication Union (ITU) in 2000 approved TD-SCDMA as a 3G mobile communications standard. This approval is regarded as a milestone event for the technological progress of the telecommunications industry in China (Gao et al., 2012).

### **6.3. Research Data and Methodology**

Section 6.2 reviews how Chinese and Korean companies obtained their technological capability in mobile communications. Before addressing my main

discussion, I explain my data, that is, essential patents.

Numerous empirical studies used essential patents to understand the dynamics of standardization (Bekkers et al., 2002; Rysman et al., 2008; Simcoe et al., 2009; Layne-Farrar, 2011). Once a (technical) standard is completed, the legally protected (usually by patents) technologies to implement the standard become essential patents. In this sense, a set of essential patents is part of the (technical) standard per se. From a legal perspective, implementing a standard without the essential patent licenses from the owners is impossible. This situation results in the hold-up problem (Shapiro, 2001; Lemley et al., 2007). Therefore, whoever intends to implement a standardized system needs to own at least one essential patent to ease license agreements if the other owners are competitors in a market. In fact, many companies in the mobile communications industry make great efforts to obtain essential patents in the standardization process (Leiponen, 2008; Bekkers et al., 2011; Berger et al., 2012; Kang et al., 2012; Kang et al., 2013). I believe that using essential patents is the best methodology for an empirical study like this and that finding alternative methodologies to analyze Chinese and Korean efforts in the mobile communications standardization is very difficult.

I retrieved the list of essential patents from the ETSI Special Report 000314 (Version March, 2012) and focused on WCDMA and LTE, which are recognized as the most globally successful technical standards in mobile communications, with services provided globally. I retrieved the list of the essential patents reported in 25 and 36 series in the ETSI SR 000314, including the specification of WCDMA and LTE in Third Generation Partnership Project (3GPP), respectively. Then, I drop essential patents only for TD-SCDMA (TS 25.221, TS 25.222, TS 25.223, TS 25.224, and TS 25.225). Moreover, no essential patents for TD-LTE are included in the ETSI's report used. Patent statistics for each essential patent, such as citations, assignees, application date, and others, were obtained by matching the essential patents with the EPO PATSTAT patent database (Ver. October 2011). One must know that the list of essential patents is reported based on a declaration of the patent owners. Thus, the risk exists that the list is over- or under-declared (Bekkers et al., 2012b). Because verification of the essentiality of the essential patents requires technical expertise and no database exists that verifies essential patents, I believe that ETSI's database is the best one for a study such as this. Thus, I note this issue as a limitation of this chapter.



Special attention must be paid when using patent data analysis to ensure that the analysis results from the data are not highly skewed. For example, a patent can be selectively applied to several patent offices. Additionally, several patents that are occasionally applied to a single patent office represent one invention divided into several applications, and so on. Accordingly, I observe my data per patent family to avoid any double-counting of single inventions. I limit my patent data to only those patents applied to the U.S. Patent and Trademark Office (USPTO). Throughout the dataset construction work, 3,916 essential patents for WCDMA and LTE were obtained.

## **6.4. Analysis**

### **6.4.1. Number of essential patents owned by Chinese and Korean companies**

The first analysis shows how active Chinese and Korean companies are in 3GPP standardization in terms of the number of essential patents that they own. This analysis indicates the degree of their participation in standardization by focusing on their invention activities. I count the (cumulative) number of essential patents by application year of each patent, and group the essential patents by the owner's home base (Figure 6.1). Then, Figure 6.1 is reconfigured as the share of essential patents owned by Chinese and Korean companies compared with the number of all essential patents in Figure 6.2.

Before 2000, companies in the U.S., Europe, and Japan owned most of the essential patents (more than 90%). That is, companies in China and Korea owned fewer than 10% of essential patents. This result is not surprising given the long history of mobile communications in these countries (Dahlman et al., 2008). In 1981, Nordic Mobile Telephony and AMPS existed, which were developed in Europe and the U.S., respectively. Then, in the 1990s, Europe and the U.S. developed digital mobile communication systems such as GSM and Digital AMPS. Also in the 1990s, Japan developed its own mobile communication standard, called Personal Digital Cellular (PDC). However, the number of essential patents owned by Chinese and Korean companies rapidly increased in the 2000s, and the increase in essential patents owned by Korean companies was dramatic. Korean companies owned fewer than 10 essential patents in the mid-1990s, but in 2010 achieved the second largest share of essential patents after the U.S. companies. Although the curve representing

China's ownership is smoother than that of Korea (Figure 6.1), Chinese companies were also successful in owning essential patents. Meanwhile, Chinese companies had less than 10 essential patents in 2001 but had ten times more than that in 2010. In Figure 6.1, the difference between the steep curve of China and that of Korea is a result of the fact that China has its own 3G mobile communication standard, TD-SCDMA. TD-SCDMA was accepted by the ITU as a 3G standard in 2000 together with CDMA2000 and WCDMA.<sup>31</sup> However, commercializing TD-SCDMA took nine years.<sup>32</sup> Although most developed countries attempted to deploy post-3G standards in late 2010, Chinese firms focused on their 3G standard. Chinese firms did participate in a post-3G global standard (LTE) they attempted to do so through their own domestic post-3G standard, called TD-LTE or LTE-TDD. Because TD-SCDMA is deployed only in China and the Chinese market itself was large enough, Chinese companies did not participate in developing WCDMA, the globally deployed 3G standard. In contrast, Korea did not have its own 3G mobile communications standard; therefore, Korean companies had to participate in the global standardization process from an early phase.

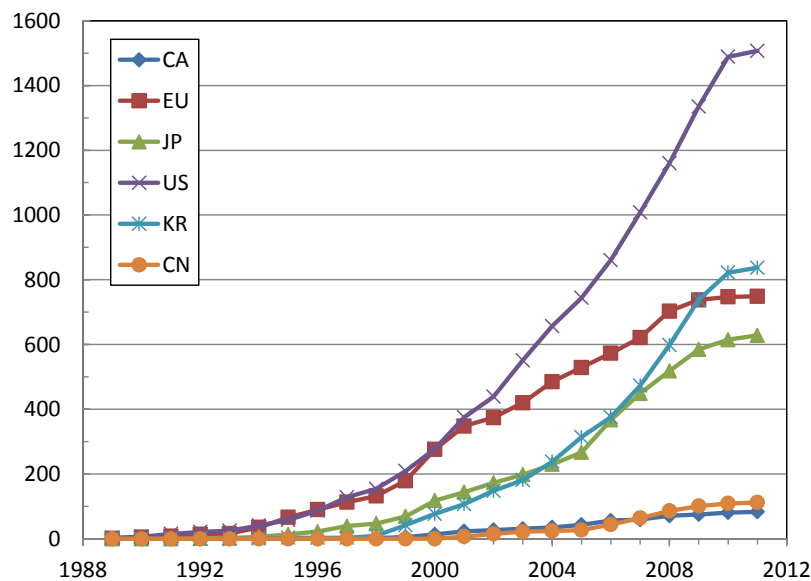

Figure 6.1. (Cumulative) Number of essential US patent families (by home base of firms)

<sup>31</sup> At ITU's World Radio Conference in Istanbul, 2000.

<sup>32</sup> MIIT licensed TD-SCDMA to China Mobile in 2009.

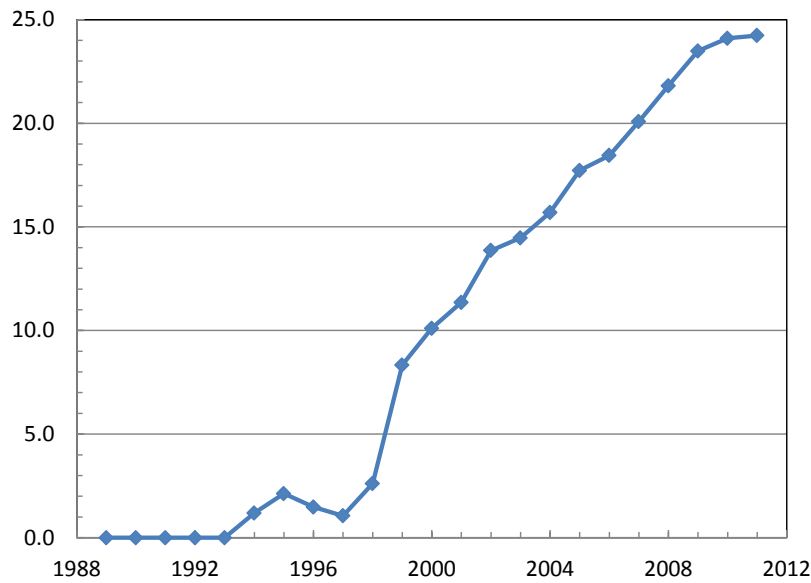

Figure 6.2. Share of essential patents owned by Chinese and Korean companies

#### 6.4.2. Citation analysis of essential patents applied by China and Korea

As noted, Chinese and Korean companies have made significant contributions to developing technical standards in the mobile communications industry in terms of the number of essential patents. Surprisingly, they have considerable portions of essential patents in WCDMA and LTE despite their short history in the industry. However, the question is the degree of Chinese and Korean companies' dependence on external (foreign) or internal (domestic) knowledge in acquiring essential patents. Bekkers et al. (2012a) visualized the knowledge positions of firms in the WCDMA market by analyzing patent citations among the firms. A significant portion of knowledge in essential patents was found to come from the large European and U.S. companies such as Ericsson, Motorola, Nokia, and Qualcomm. In fact, as reviewed in Section 2, knowledge from abroad was transferred to Chinese and Korean companies from the European and U.S. companies. I ask myself the following questions: Has the knowledge transfer adequately increased the technological capability for those companies to participate in the standardization using their own technological capability? Or, is the participation of those companies still dependent on external knowledge in standardization?

To answer these questions, I conducted a citation analysis of essential patents. I focused on the national origins of backward citations by finding the

addresses of patent applicants and calculated the proportion of the national origins. I defined six categories of sources of knowledge: China, Europe, Japan, Korea, the U.S., and others. The list of “others” includes Australia, Canada, Eastern Europe, Israel, New Zealand, and Russia. Generally, when using patent data applied only to one patent office, citation analysis has drawbacks, the main one of which is that a significant proportion of citations in a patent application to a patent office comes from domestic references of the patent office (Michel et al., 2001). For example, many patent application citations to the European Patent Office were references from Europe. Thus, in my study, a significant number of citations in a patent may come from the U.S. references. Nevertheless, because I attempt to observe whether knowledge transfer occurs not from/to the U.S. but from/to China and Korea, the bias does not influence my data analysis. To observe progress over time, I show knowledge flow every five years.<sup>33</sup>

The results are shown in Figures 6.3-1, 6.3-2, 6.3-3, 6.3-4, 6.4-1, and 6.4-2, which indicate how knowledge transfer changed every five years. Figures 6.3-1, 6.3-2, 6.3-3, and 6.3-4 show how Korean companies’ dependency on foreign knowledge decreased. Essential patents applied by Korean companies until 1995 entirely relied on the knowledge received from abroad. However, those until 2010 relied on 17% of the knowledge obtained within Korea. This share is almost the same as the knowledge flow from Japanese companies. Knowledge reliance on the Triad declined from 100% to 77% for two decades, implying that, although knowledge flow from leading countries is still important, knowledge has accumulated within Korea and this accumulated knowledge worked positively to assist Korea in participating in the ICT global standardization. Additionally, this development is interpreted as Korea’s standard policy being aligned with the global main trajectory. Meanwhile, the case for China is different and shows that the country’s reliance on its own knowledge grew from 5% to 6% (Figures 6.4-1 and 6.4-2) but that Chinese firms heavily depend on the Triad and Korea. This result indicates that knowledge accumulation from the development of its own standard

---

<sup>33</sup> One may propose to show the progress by comparing WCDMA and LTE. However, I decided to conduct analysis based on time for the following reasons: one of the reasons is that, on many occasions, an essential patent is declared for both WCDMA and LTE, and finding the border of WCDMA and LTE is difficult. A second reason is that both are standardized in the 3GPP RAN1 group and by the same group of people (Kang et al., 2013). Thus, no clear difference is expected.

takes a long time, and that knowledge is not aligned with the global main trajectory because of China's policy to develop its own 3G standard.

Two points common to both China and Korea are worth discussing. First, for both Korea and China, a significant proportion of their knowledge is from the U.S. despite a citation bias by the patent office. Therefore, the true leader in this industry is the U.S. even today. Second, although China and Korea gained technological capabilities before their participation in global standardization, as explained in Section 6.2, their leverage over standardization was very limited, indicating that technological capabilities obtained through a catch-up process does not guarantee successful participation in standardization. In fact, non-technological factors are important to obtaining essential patents in standardization (Bekkers et al., 2011; Kang et al., 2013).

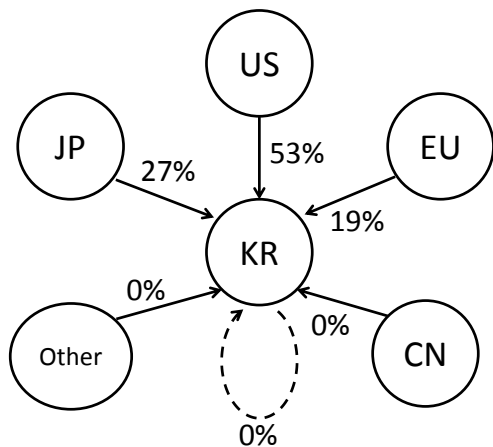

Figure 6.3-1. Knowledge base of essential patents: Case of Korea (~1995)

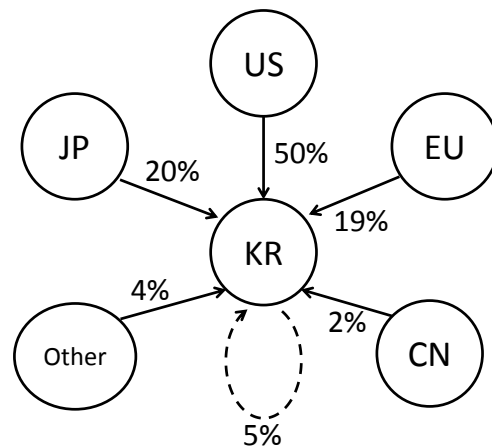

Figure 6.3-2. Knowledge base of essential patents: Case of Korea (~2000)

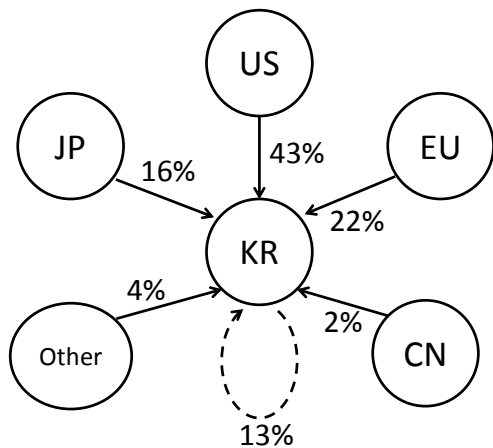

Figure 6.3-3. Knowledge base of essential patents: Case of Korea (~2005)

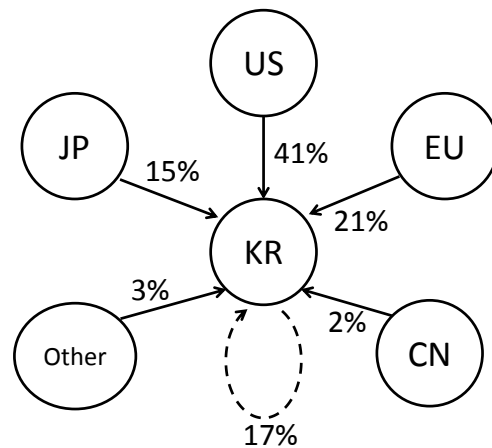

Figure 6.3-4. Knowledge base of essential patents: Case of Korea (~2010)

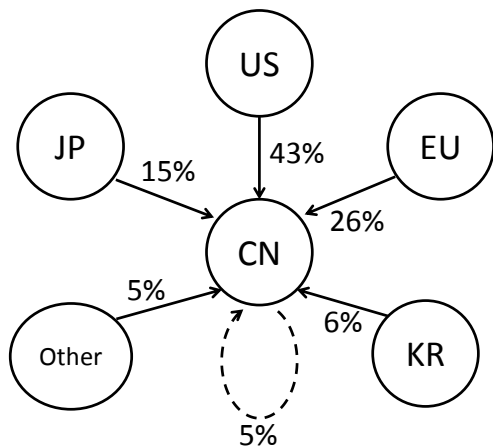

Figure 6.4-1. Knowledge base of essential patents: Case of China (~2005)

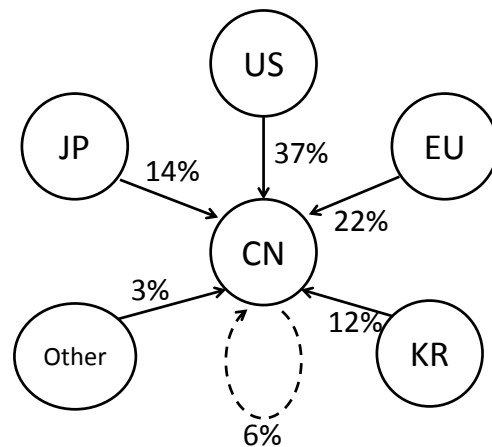

Figure 6.4-2. Knowledge base of essential patents: Case of China (~2010)

### 6.4.3. Technological value of essential patents owned by Chinese and Korean companies

Figures 6.3-1, 6.3-2, 6.3-3, 6.3-4, 6.4-1, and 6.4-2 show that China and Korea have accumulated the knowledge necessary for ICT global standardization. However, the next question is, what is the value of essential patents invented by Chinese and Korean companies as an output? Does owning a number of essential patents mean significantly contributing to standardization in terms of technological development? This section answers these questions.

To answer these questions, I conducted a Tobit regression. The dependent variable is the number of (normalized) forward citations, which is used as a proxy for the technological value of a patent (Carpenter et al., 1981; Karki et al., 1997). Old patents are would probably be cited more frequently than recent ones, which becomes a bias in citation analysis. Therefore, I divide the number of forward citations by the average number of forward citations from the same application year and international patent classification (IPC) (Jaffe et al., 2002). The independent variables are five regional dummy variables: Canada,<sup>34</sup> China, Europe, Japan, and Korea, with a greater interest in the variables for China and Korea. To avoid the dummy variable trap (Greene, 2011), I do not define a dummy variable for the U.S. Thus, the baseline in this regression model is the U.S. I add control variables to the regression analysis, the first of which is a dummy variable for whether the essential patent of interest cites other essential patents (= 1) or not (= 0). Adding this variable enables testing of the effect of knowledge flow from prior standards. By multiplying this variable with the main independent variables of interest—China and Korea—I add two interaction terms. The second control variable is Log10 of the stock number of patents in mobile communications per firm, which is used as a proxy for firm size. I use IPCs of essential patents for any patents classified into those IPCs from the Derwent Innovations Index. The third control variable is Log10 of the stock number of essential patents per firm, which is used as a proxy for firms' cumulative effort in standardization. Finally, the fourth control variable is application year. Dummy variables were defined for each application year.

Table 6.1 shows the results, including the coefficients and t-statistics. First, China and Korea—the independent variables of interest—have negative effects and negative statistical significance at the 1% level in regression models 2 and 5, respectively. They also have negative effects and statistical significance at the 1% level in regression models 6–11 when control variables are added. This result indicates that the essential patents applied by Chinese and Korean companies are

---

<sup>34</sup> In my dataset, the Canadian companies contain Northern Telecom (Nortel). This paper still counts Nortel even though Apple, Microsoft, and Research in Motion (RIM) acquired its patent portfolio in 2010 because Nortel was one of the dominant incumbent companies in the mobile communications industry and constructed a giant patent portfolio. In addition, the lack of Nortel's patent applications in 2011 does not change the results of my analysis.

less cited by subsequent patent applications than those by the U.S. companies. The difference between Korea and China is that Korea's coefficient is as low as that of Japan's and China's coefficient is the lowest. Second, for any regression model, the coefficients for Europe and Japan are lower than the base (the U.S.), and Canada appears higher than the base. In this model, Canada's essential patents are those declared essential by Nortel and RIM. Whereas the other regions, even the EU and U.S., include large, small, old, young, incumbent, and new companies, Canada has only two companies and both were dominant firms in 2000s. Therefore, that the coefficients for Canada have the largest values is not surprising. I conclude that the U.S. creates the most technologically valuable inventions related to standardization.

In addition, an interesting finding is observed from the analysis of the control variables. The first control variable has positive effects and statistical significance at the 1% level in regression models 7–11. This result indicates that the technological contribution by essential patents is positively affected by the knowledge spillover from prior essential patents. Each interaction term obtained by multiplying China and Korea, respectively, has positive effects. The interaction term with Korea is statistically significant at the 1% level, but that for China is not. This result indicates that because Korea's standard strategy is to go with the global main trajectory, the country actively and effectively absorbs knowledge from the standard to lead standardization.



Table 6.1 Regression result

DV: the number of forward citations											
	1	2	3	4	5	6	7	8	9	10	11
Canada	3.7139					2.625	2.8145	2.7795	2.7896	2.5757	3.3015
	[4.90]***					[3.44]***	[3.68]***	[3.64]***	[3.65]***	[3.19]***	[3.97]***
China		-3.0312				-3.916	-3.7525	-4.1807	-4.1688	-4.4493	-2.7255
		[-3.95]***				[-5.09]***	[-4.85]***	[-4.70]***	[-4.67]***	[-4.65]***	[-2.71]***
Europe			0.2157			-0.828	-0.6235	-0.6603	-0.7009	-0.7747	-1.9723
			[0.75]			[-2.66]***	[-1.99]**	[-2.11]**	[-2.23]**	[-2.37]**	[-5.69]***
Japan				-1.6141		-2.3481	-2.2017	-2.2257	-2.064	-2.2198	-2.1221
				[-4.99]***		[-6.79]***	[-6.34]***	[-6.42]***	[-5.66]***	[-5.39]***	[-4.91]***
Korea					-1.4048	-2.0982	-2.0547	-2.5235	-2.2026	-2.2629	-2.2065
					[-4.87]***	[-6.72]***	[-6.55]***	[-6.89]***	[-5.13]***	[-5.20]***	[-4.79]***
Citing prior essential patents							2.1368	1.7626	1.7688	1.7763	0.3814
							[8.19]***	[5.94]***	[5.96]***	[5.98]***	[1.22]
[China] x [Citing prior essential patents]								1.6978	1.435	1.5138	1.5138
								[0.95]	[0.80]	[0.84]	[0.82]
[Korea] x [Citing prior essential patents]								1.5832	1.5659	1.5423	2.153
								[2.50]**	[2.47]**	[2.43]**	[3.26]***
Log10_NumPatStock									-0.3114	-0.2131	0.0242
									[-1.44]	[-0.86]	[0.09]
Log10_NumEssPat										-0.2609	0.6187
										[-0.82]	[1.86]*
AppYear	No	No	No	No	No	No	No	No	No	No	Yes
Constant	-0.8475	-0.694	-0.5171	-0.4792	-0.8171	0.2593	-0.3984	-0.2793	0.8224	1.1278	-9.7426
	[-6.78]***	[-5.55]***	[-3.91]***	[-3.53]***	[-5.92]***	[1.40]	[-1.94]*	[-1.34]	[1.04]	[1.29]	[-8.24]***
Sigma_contant	6.558	6.5751	6.562	6.5672	6.5876	6.4819	6.4843	6.4755	6.476	6.4782	6.5118
	[62.74]***	[62.73]***	[62.75]***	[62.75]***	[62.64]***	[62.80]***	[62.77]***	[62.77]***	[62.77]***	[62.73]***	[61.95]***
N	3916	3916	3916	3916	3916	3916	3916	3916	3916	3916	3916

\* p<0.1, \*\* p<0.05, \*\*\* p<0.01

## 6.5. Conclusions, Discussion and Implications

This chapter presented an empirical analysis of Asian countries' rise in ICT global standardization using China and Korea. I reviewed the historical background on how China and Korea obtained their technological capabilities in the mobile communication industry before participating in ICT global standardization. Then, to address my main interest, I focused on Chinese and Korean companies in 3GPP, WCDMA, and LTE and compared their standard strategy. The findings are as follows.

- (1) Despite their short histories in ICT global standardization, the number of essential patents applied in WCDMA and LTE by Korean companies has been rapidly increasing, even though most essential patents still come from the U.S. companies. The proportion of the number of essential patents applied by Korea is increasing, indicating that Korea selected the global main standard trajectory as its national standard strategy and concentrates its resources on catching up, that is, path-following catch-up (Lee et al., 2001). In contrast, Chinese companies also obtained essential patents in WCDMA and LTE. However, the increase in the essential patents obtained by Chinese companies was not as rapid as that of Korean companies. Because China leverages its huge domestic market, it decided to not follow the global main trajectory but, instead, decided

to create its own standard for its domestic market, that is, path-creating catch-up or leapfrogging II (Lee et al., 2001).

- (2) Using an analysis of citations of essential patents applied by Chinese and Korean companies, I measured their knowledge reliance on the Triad. In the early 1990s, Korean companies completely relied on the Triad. However, over time, their accumulated domestic knowledge contributed more to obtaining essential patents, although a significant amount of knowledge still comes from leading countries. Korean firms have become as competitive as Japanese firms in standardization. Meanwhile, Chinese companies still significantly depend on foreign knowledge, implying that knowledge accumulation in China through the development of the domestic standard takes a considerable amount of time. For both countries, the main source of knowledge is the U.S.
- (3) The regression result supports my findings in (2). Essential patents of Korean and Chinese firms have lower technological value than those of the U.S. firms. However, Korean firms' essential patents have almost similar technological value as those of Japanese firms. Korea's efforts to absorb prior knowledge in the standard results in creating technologically valuable inventions. Chinese firms' essential patents have the least technological value.

My findings provide several implications. The first implication is for any country that targets the Chinese market. My analysis shows that China's standard strategy is to concentrate on its domestic standard aimed at its domestic market rather than the primary global standard. Thus, China's strategy might have delayed improvements in its technological capability and the formation of its market, indicating that a risk exists that China's standard may be derailed from the global standard trajectory and, consequently, the country's market may be left behind. Nevertheless, the Chinese market remains very attractive for any firm given its size. China's standard-deployment scenario may influence a standard trajectory and possibly threaten a leading country. Thus, any country—particularly the leading country—that targets the Chinese market must adopt an ambidextrous strategy and focus on the Chinese market and remain competitive in the global market.

Second, this chapter offers implications for other following countries. If another following country attempts to establish a standard strategy for a national

innovation, it must consider its domestic market size. China was able to establish a domestic standard—albeit late and technologically inferior—because of its market size. Its decision to use its domestic market may change the standard trajectory. In contrast, Korea focused on and put all of its domestic resources into the global mainstream. As a result, it quickly caught up in global standardization. If a following country owns a large domestic market, China is the model from which to learn. Otherwise, Korea is the model from which to learn.

Third, an additional implication exists related to complementary assets for other following countries. The market for the mobile communications industry is formed by emergence of a standard. However, the standard leader is not necessarily the downstream market leader. Although Chinese firms have not been the main contributors to global standardization, they hold significant global market share in the infrastructure vendor and the mobile term markets, attaining its market share through complementary assets such as low-cost manufacturing. This fact implies that nurturing competitive complementary assets is important (Teece, 1986). Even if the standard is led by leading countries, a new entrant may gain leverage over a market that emerges through the formation of a standard by applying its complementary assets.

Finally, the proliferation of essential patents has accelerated and is an unavoidable phenomenon that resulted from the growth in the technological capability of latecomers. Given the nature of essential patents, any firm that wants to implement a particular standard must obtain a license from the essential patent owner. From the legal perspective, the essential patent is undoubtedly a powerful asset whether or not it has high technological value. If reaching a licensing agreement between any essential patents holder fails, then a market cannot form. Even if incumbent firms that are the owners of essential patents form a market, new entrants face the barrier of paying a licensing fee. Some may say that the essential patent owner must license under fair, reasonable, and non-discriminatory (F/RAND) conditions. However, no definite requirement for F/RAND licensing exists and the results of lawsuits between firms, notably between conglomerate ones, are ambiguous. Thus, the tension that exists between firms will increase from the proliferation of essential patents.

## **Chapter 7: Conclusions -Summary, implications, and future research agenda-**

### **7.1. Summary**

The summary of each chapter is as follows:

Chapter 1 is the introduction of this study. It provided the background and the prior literature to understand the discussions in this thesis.

Chapter 2 introduced the research methodology used in this study. In detail, I introduced lists of the patent statistics which were used in this study, and the research data.

Chapter 3 showed firms' efforts to obtain essential patents. Obtaining essential patents is important for innovation competition in the network industry, where technical standardization plays a critical role in development. In Chapter 3, I empirically investigated the determinants of essential patents for wireless communications standards by using the patent database. More specifically, I used the technological capabilities of both the firm and the patent inventor to explain the probability of its selection as an essential patent. In addition, I compared manufacturing firms' and non-practicing entities' (NPEs) technology strategies for essential patents. Our results indicate that manufacturing firms accumulate their technological capability in specific technology fields, whereas NMPs cover broader technology fields to keep their dominant position in the standardization process.

Chapter 4 presented an in-depth investigation on the standardization process of the successful Wideband-Code Division Multiple Access (W-CDMA) and Long Term Evolution (LTE) standards for mobile telecommunications. I studied the first 77 meetings where these standards took shape, covering a period of over 12 years, and identified the patenting behavior of each of the 939 individual

participants attending these meetings, as well as the patenting behavior by non-participants, together resulting in over 14,000 patents for this technology. The data revealed a strong relationship between patent timing and the occurrence of meetings. I observed a remarkable phenomenon that I call 'just-in-time-inventions': the patent intensity of about-to-become claimed essential patents is much higher during or just before these meetings than in other periods. At the same time, they were of considerably lower technical value ('merit'). This suggested that the just-in-time inventions are only beneficial to their owners, whereas for the public they merely invoke unnecessary costs. Finally, I observed that the phenomenon of just-in-time inventions is highly concentrated among specific types of firms, above all vertically integrated ones, and the incumbent champions of the previous technology standard.

Chapter 5 investigated empirically how essential patents play a role as a knowledge source for future R&D. The firms owning essential patents were classified by their business models, and it was investigated how significantly each business model manages the technical standards for their R&D activities by comparing knowledge sources. The results indicate that there is significant difference among different business models in utilizing each knowledge source for their R&D activities. NPEs conducted R&D based on technical standards. Chipset vendors actively conducted R&D based on technical standards. Manufacturers conducted R&D based on their internal knowledge. However, manufacturers from China and Korea are less likely conduct R&D based on their internal knowledge.

Chapter 6 observed the current situation of Asian countries in ICT global standardizations from the point of view of mobile communications standards, WCDMA and LTE, and derived interesting findings and meaningful implications from the analysis. In detail, I conducted our analysis based on (declared) essential patents. I identified that the list of WCDMA and LTE essential patents, and found other information by matching the list to patent database. From the analysis, I found that Asian countries occupy a significant proportion of essential patents. In terms of the number of essential patents, Asian countries compete against leading countries. At the same time, the analysis of essential patents showed that their efforts to develop a standard originate more from domestic knowledge, and their dependence on the knowledge of leading countries is decreasing. However, I also found that there is still a gap between leading countries, especially U.S., and Asian

countries. Chinese and Korean contribution to standardization in terms of technological value is still small. This describes some limitation in Chinese and Korean efforts. However, under some condition, their contribution was non-negligible compared to that of the leading countries, which provides a hint where and how China and Korea as well as other Asian countries must proceed from now on.

## **7.2. Implications**

This thesis provides important implications. First, there is a risk for owners of essential patents to privatize the standard. In mobile communications industry where network effect is large, a standard does a key role for the industry-wide innovation. In Chapter 3, collaboration between firms at the standardization rake distributed specialties to make a standard to push innovation at first glance. However, in-depth analyses showed evidence that firms use an opportunistic patent filing to obtain the essential patents. In Chapter 6, China and Korea achieved fast catch-up in owning essential patents, but their technological contribution is still limited in the standardization. Their efforts to get essential patents are aimed to block any competitor from privatizing the standard.

Second, as a result of the risk, tension between firms, especially between NPEs and manufacturers, could be observed. Essential patents are very attracted especially for NPE whose main revenue source is licensing fee. NPEs generate many standard-based inventions to get might-be-infringed patents. Manufacturers have to get essential patents before NPEs get them. That is why Korean and Chinese firms, all of which are manufacturers, also needed to get essential patents. The tension led the situation where, despite great R&D efforts to obtain essential patents, manufacturers, who are the main implementers, do not conduct additional R&D on top of the standard. That is a waste of energy and resource, and increases the social costs which will be paid by customers in the end. And, we must remember that any implementing firm can turn into an NPE. In fact, we observe any implementing firm failed in the market, once a market leader, files lawsuits against competitors using its dominant ownership of the essential patents.

Taken together, I conclude that patents in standards, a.k.a. essential patents, have a limitation to push innovation. The phenomena are resulted thanks

to the legal powerfulness of the essential patents. As a result, firms pay too much interest in essential patents. Essential patents provide owners exclusive ownership in the public property. The exclusive ownership in the public property increases unnecessary social costs and blocks fair competition. Thus, fair, reasonable, and non-discriminatory (FRAND) terms for essential patents must be respected so as to lessen the exclusive ownership in the public property. In addition, we need a third party which can evaluate claimed essential patents and filter out unsuitable essential patents. One may propose essential patent pooling, but pooling the essential patents is not enough because concerns will be raised who to lead, how to allocate licensing revenue, etc. More study is necessary. Finally, standardization must work not only as a place to 'negotiate' the standard but also as a forum to exchange information between firms because standardization provides opportunities to combine distributed knowledge, to lessen risks, to form a market, and to direct development.

### **7.3. Limitations and Future Research Agenda**

I would like to list up a future research agenda based on the limitations found in this study. First, this study was conducted based on the case of 3GPP's standards. There is always a tradeoff between generalization and specialization in research work. To address my research question, this research work investigated in depth the case of 3GPP's standardization, and gave up generalization. In the future, one can try to generalize the findings of this study on other standards. Also, the analyses and the relevant results in this study are based on the observations of 3GPP's standards (i.e. empirical research). Thus, in the future it is possible to use a theoretical approach to discuss the findings in this study.

Second, some of the data and the indicators used to conduct the analyses in this study have endogeneity problems. For example, Chapter 3 and Chapter 4 analyzed the meeting participants' effects to claim a patent essential. It is under discussion that inventors with many essential patents are the most likely to attend the standardization meetings and get more essential patents. There is also an endogeneity problem with the essential patents. It is known that essential patents receive forward citations more than average patents, fact which is interpreted as that the essential patents are technologically more valuable than the average patents. However, some argue that essential patents receive forward citations

because they are claimed to be essential and more publicly known. Rysman et al (2008) tried to correct the problem by comparing the number of forward citations before the patents were declared essential and after the declaration, correction which was conducted in this study also (See Chapter 3).

Third, this research studied the benefits of owning essential patents in terms of R&D and technological catch-up. Dynamics of essential patents are not limited to the scope investigated in this study. For example, essential patents affect the lifetime of standards (Baron et al, 2012), and even in lawsuits, a more complex mechanism is working (Simcoe et al., 2009). In addition, according to a survey of people in the information and communication technology industry, the benefits of international standards development are globalized market formation, increased export chances, and globalized R&D and production processes (Blind et al, 2010). Thus, there are many other perspectives to better understand the dynamics of essential patents.

Fourth, this study grouped focal firms according to business model or national origin for ease of analysis. In fact, some groupings were used as a result of tendencies commonly observed from each individual firm analysis. However, those tendencies are not always applicable to all firms. For example, the tendencies of technology search are different for each firm from the case of essential patents. The authors investigated types of technology search enables firms to get essential patents from a case study in Digital Versatile Disc (DVD) and Moving Picture Experts Group (MPEG) (Wajima et al., 2010). Although most focal firms<sup>35</sup> are manufacturers, each firm behaves according to its own corporate strategy. Future research could focus on each firm's strategy and compare how each strategy differs from each other.

Finally, this study is based only on an effect of the patent system that encourages innovation by motivating the inventor (and/or the assignee) to invent and collect monetary rewards from the invention with exclusive rights over the invention. However, the patent system also encourages innovation by disclosing information about inventions. First this allows any third party to use the knowledge

---

<sup>35</sup> All the firms used in the analysis are Hitachi, IBM, JVC, LG, Mitsubishi, NTT, Panasonic, Philips, Pioneer, Samsung, Sanyo, Sharp, Sony, Thomson, and Toshiba.



freely after the patent expires. Second, one can create new knowledge around the disclosed information. Although Chapter 5 analyzed essential patents as a knowledge source, that is primitive. More elaborated research design can improve to better understand essential patents as a knowledge source.

## Reference

- Acs, Z. J., Braunerhjelm, P., Audretsch, D. B. & Carlsson, B. (2009) The knowledge spillover theory of entrepreneurship, *Small Business Economics* 32(1), 15-30.
- Adachi, F. (2001). Wireless Past and Future – Evolving Mobile Communications Systems, *IEICE Transactions on Fundamentals*, E84-A(1).
- Aggarwal, N., Dai, Q., & Walden, E. A. (2011). The More, the Merrier? How the Number of Partners in a Standard-Setting Initiative Affects Shareholder's Risk and Return, *MIS Quarterly* (35)2, 445-462
- Alcarcer, J., & Gittelman, M. (2006). Patent citations as a measure of knowledge flows: The influence of examiner citations, *Review of Economics and Statistics* 88(4), 774-779.
- Alcacer, J., Gittleman, M., & Sampat, B., (2009). Applicant and examiner citations in US patents: An overview and analysis. *Research Policy* 38, 415-427.
- Allen, R. H., & Sriram, R. D. (2000). The Role of Standards in Innovation, *Technological Forecasting and Social Change* 64, 171-181.
- Baba, Y., & Nobeoka, K. (1998). Towards knowledge-based product development: the 3-D CAD model of knowledge creation, *Research Policy* 26, 643-659.
- Baron, J., Blind, K., & Pohlmann, T. (2012). Essential Patents and Standard Dynamics. Working paper, retrieved from <http://www.intertic.org/Conference/Baron.pdf>.
- Basberg, B. L. (1982). Technological change in the Norwegian whaling industry: A case-study in the use of patent-statistics as a technology indicator, *Research Policy* 11, 163-171.
- Bekkers, R., Duysters, G., & Verspagen, B., (2002). Intellectual property rights, strategic technology agreements and market structure: The case of GSM.

- Research Policy* 31, 1141-1161.
- Bekkers, R., Verspagen, B., & Smits, J. (2002). Intellectual property rights and standardization: the case of GSM, *Telecommunications Policy* 26, 171-188.
- Bekkers, R., & West, J., (2009). The limits to IPR standardization policies as evidenced by strategic patenting in UMTS. *Telecommunications Policy* 33, 80-97.
- Bekkers, R., Bongard, R. & Nuvolari, A., (2011). An empirical study on the determinants of essential patent claims in compatibility standards. *Research Policy* 40, 1001-1015.
- Bekkers, R., Catalini, C., Martinelli, A., & Simcoe, T. (2012b). Intellectual Property Disclosure in Standards Development. NBER conference on Standards, Patents & Innovation, Tucson (AZ), January 20 and 21, 2012. Available at <http://users.nber.org/~confer/2012/IPKE/Bekkers.pdf>.
- Bekkers, R., Iversen, E., & Blind, K. (2012). Emerging ways to address the reemerging conflict between patenting and technological standardization, *Industrial and Corporate Change* 21(4), 901-931.
- Bekkers, R., & Martinelli, A. (2012b). Knowledge positions in high-tech markets: Trajectories, standards, strategies and true innovators, *Technological Forecasting & Social Change* 79(7), 1192-1216.
- Bekkers, R., & Updegrave, A. (2012). A study of IPR policies and practices of a representative group of Standards Setting Organizations worldwide. Washington, DC: National Academies of Science. Retrieved from [http://sites.nationalacademies.org/xpedio/groups/pgasite/documents/webpage/pgasite\\_072197.pdf](http://sites.nationalacademies.org/xpedio/groups/pgasite/documents/webpage/pgasite_072197.pdf).
- Berger, F., Blind, K., & Thumm, N., (2012). Filing behavior regarding essential patents in industry standards. *Research Policy* 41, 216-225.
- Besen, S. M., & Levinson, R. J. (2012). Introduction to the special issue on the use

- and abuse of voluntary standard-setting processes in a post-RAMBUS world: Law, economics, and competition policy. *Antitrust Journal* 75(1), 1-16.
- Blind, K., & Thumm, N. (2004). Interrelation between patenting and standardization strategies: empirical evidence and policy implications, *Research Policy* 33, 1583-1598.
- Blind, K., Gauch, S., & Hawkins, R. (2010). How stakeholders view the impacts of international ICT standards. *Telecommunications Policy* 34, 162-174.
- Blind, K., Bekkers, R., Dietrich, Y., Iversen, E., Köhler, F., Müller, B. et al. (2011a). Study on the Interplay between Standards and Intellectual Property Rights (IPRs). Final Report. Study commissioned by the European Commission Tender No ENTR/09/015 (OJEU S136 of 18/07/2009). Brussels: European Commission. Retrieved from [http://ec.europa.eu/enterprise/policies/european-standards/standardisation-policy/policy-activities/intellectual-property-rights/index\\_en.htm](http://ec.europa.eu/enterprise/policies/european-standards/standardisation-policy/policy-activities/intellectual-property-rights/index_en.htm).
- Blind, K., Neuhaeusler, P., & Pohlmann, T. (2011b). Standard essential patents to boost financial returns. Paper at the 6th Annual Conference of the EPIP Association, September 8-9, 2011.
- Brockhoff, K. K. (1992). Instruments for patent data analyses in business firms, *Technovation* 12(1), 41-58.
- Callaert, J., Van Looy, B., Verbeek, A., Debackere, K., & Thijs, B. (2006). Traces of Prior Art: An analysis of non-patent references found in patent documents, *Scientometrics* 69(1), 3-20.
- Carpenter, M., Narin, F., & Woolf, P. (1981). Citation rates to technologically important patents, *World Patent Information* 3(4), 160-163.
- Chan, Y., & Walmsley, R. P. (1997). Learning and Understanding the Kruskal-Wallis One-Way Analysis-of-Variance-by-Ranks Test for Differences Among Three or More Independent Groups. *Physical Therapy* 77(12).

- Chapuis, R. J., & Joel, A. E. (2003). *100 Years of Telephone Switching: Electronics, Computers, And Telephone Switching 1960-1985*, IOS Press.
- Chiao, B., Lerner, J., & Tirole, J. (2007). The rules of standard-setting organizations: an empirical analysis. *RAND Journal of Economics* 38(4), 905-930.
- Clark, J., Piccolo, J., Stanton, B., & Tyson, K. (2000). Patent pools: a solution to the problem of access in biotechnology patents?, USPTO.
- Cohen, W., & Levinthal, D. (1990). Absorptive capacity: A new perspective on learning and innovation. *Administration Science Quarterly* 35, 128-152.
- Cohen, W., Goto, A., Nagata, A., Nelson, R., & Walsh, J. (2002). R&D spillovers, patents and the incentives to innovate in Japan and the United States, *Research Policy* 31, 1349-1367.
- Criscuolo, P., & Verspagen, B. (2008). Does it matter where patent citations come from? Inventor vs. examiner citations in European patents, *Research Policy* 37, 1892-1908.
- Cusumano, M., Mylonadis, Y., & Rosenbloom, R. (1992). Strategic maneuvering and mass-market dynamics: the triumph of VHS over beta, *Business History Review* 66(1), 51-94.
- David, P. A. (1985). Clio and the Economics of QWERTY, *The American Economic Review* 75(2), 332-337.
- Dahlman, E., Parkvall, S., Skold, J., & Beming, P. (2008). *3G Evolution: HSPA and LTE for Mobile Broadband* (2nd edition), Academic Press.
- Diwan, I., & Rodrik, D. (1991). Patents, Appropriate Technology, and North-South Trade, *Journal of International Economics* 30(1-2), 27-47.
- Dokko, G., & Rosenkopf, L. (2010). Social Capital for Hire? Mobility of Technical Professionals and Firm Influence in Wireless Standards Committees, *Organization Science* 21(3), 677-695.

- Dunphy, S. M., Herbig, P. R., & Howes, M. E. (1996). The Innovation Funnel, *Technological Forecasting and Social Change* 53, 279-292.
- Ernst, H. (1998) Patent portfolios for strategic R&D planning, *Journal of Engineering and Technology Management* 15, 279-308.
- Ernst, H., Leptien, C., & Vitt, J. (2000). Inventors Are Not Alike: The Distribution of Patenting Output Among Industrial R&D Personnel, *IEEE Transactions on Engineering Management* 47(2), 184-199.
- Escribano, A., Fosfuri, A., & Tribo, J. A. (2009). Managing external knowledge flows: The moderating role of absorptive capacity, *Research Policy* 38, 96-105.
- ETSI, (2011). Intellectual Property Rights (IPRs) Essential, or Potentially Essential IPRs Notified to ETSI in Respect to ETSI Standards, 2011 (ETSI SR 000 314 V2.10.1 (2011-06)).
- ETSI, (2012). Annex 6: ETSI Intellectual Property Rights Policy. ETSI Directives version 29, January 2012. (URL: [http://portal.etsi.org/directives/29\\_directives\\_jan\\_2012.pdf](http://portal.etsi.org/directives/29_directives_jan_2012.pdf))
- ETSI, (2013). Annex 6: ETSI Intellectual Property Rights Policy. ETSI Rules of Procedure, 20 March 2013. (URL: [http://www.etsi.org/images/etsi\\_ipr-policy.pdf](http://www.etsi.org/images/etsi_ipr-policy.pdf))
- Fabry, B., Ernst, H., Langholz, J., & Koster, M. (2006). Patent portfolio analysis as a useful tool for identifying R&D and business opportunities – an empirical application in the nutrition and health industry, *World Patent Information* 28, 215-225.
- Fan, P. (2006). Catching up through developing innovation capability: evidence from China's telecom-equipment industry. *Technovation* 26, 359-368.

- Farrell, J., & Saloner, G. (1986). Installed Base and Compatibility: Innovation, Product Preannouncements, and Predation, *The American Economic Review* 76(5), 940-955.
- Farrell, J., Hayes, J., Shapiro, C., & Sullivan, T. (2007). Standard setting, patents, and hold-up. *Antitrust Law Journal*, 74(3), 603-670.
- Fischer, T., & Henkel, J. (2012). Patent trolls on markets for technology – An empirical analysis of NPEs’ patent acquisitions, *Research Policy* 41, 1519-1533.
- Fontana, R., Nuvolari, A., & Verspagen, B. (2009). Mapping technological trajectories as patent citation networks. An application to data communication standards. *Economics of Innovation and New Technologies* 18, 311-336.
- FTC (2011). The Evolving IP Marketplace: Aligning Patent Notice And Remedies With Competition. Federal Trade Commission.
- Fung, M. K., & Chow, W. W. (2002) Measuring the intensity of knowledge flow with patent statistics, *Economics Letters* 74, 353-358.
- Gallagher, S., & Park, S. H. (2002). Innovation and competition in standard-based industries: A historical analysis of the U.S. home video game market, *IEEE Transactions on Engineering Management* 49(1), 67-82.
- Gallagher, S. (2012). The battle of the blue laser DVDs: The significance of corporate strategy in standards battles, *Technovation* 32, 90-98.
- Gallini, N. T. (2002). The Economics of Patents: Lessons from Recent U.S. Patent Reform, *Journal of Economic Perspectives* 16(2), 131-154.
- Gambardella, A., Giuri, P., & Luzzi, A. (2007) The market for patents in Europe, *Research Policy* 36(8), 1163-1183.

- Gambardella, A., Harhoff, D., & Verspagen, B. (2008). The value of European patents. *European Management Review* 5(2), 69-84.
- Gandal, N., Gantman, N., & Genesove, D. (2006). "Intellectual property and standardization committee participation in the US modem industry," in Shane Greenstein and Victor Stango, eds., *Standards and Public Policy*, Cambridge University Press, 208-230.
- Gao, X., & Liu, J. (2012). Catching up through the development of technology standard: The case of TD-SCDMA in China, *Telecommunications Policy* 36, 531-545.
- Geradin, D., Layne-Farrar, A., & Padilla, A. J. (2008). The Complements Problem Within Standard Setting: Assessing the Evidence on Royalty Stacking. *Boston University Journal of Science & Technology* 14(2), 144-167.
- Gnyawali D. R., & Park, B.-J.(2009). Co-opetition and Technological Innovation in Small and Medium-Sized Enterprises: A Multilevel Conceptual Model, *Journal of Small Business Management* 47(3), 308-330.
- Gnyawali D. R., & Park, B.-J.(2011). Co-opetition between giants: Collaboration with competitors for technological innovation, *Research Policy* 40, 650-663.
- Goldsmith, A., (2005). *Wireless Communications*, Cambridge University Press, Cambridge.
- Goodman, D.J., Myers, R.A., (2005). 3G Cellular Standards and Patents. 2005 International conference on Wireless Networks, Communications and Mobile Computing, 415-420.
- Goto, A., & Motohashi, K. (2007). Construction of a Japanese Patent Database and a first look at Japanese patenting activities, *Research Policy* 36, 1431-1442.
- Granstrand, O., Patel, P., & Pavitt, K. (1997). Multi-Technology Corporations: Why They Have "Distributed" rather than "Distinctive Core" Competences. *California Management Review* 39(4), 8-25.



- Greene, W. H. (2011). *Econometric Analysis* (7th ed.). Pearson Prentice Hall.
- Griliches, Z., (1990). Patent Statistics as Economic Indicator: A Survey, *Journal of Economic Literature* 28(4), 1661-1707.
- Hagedoorn, J. (2002). Inter-firm R&D partnerships - an overview of major trends and patterns since 1960, *Research Policy* 31, 477-492.
- Hall, B. H., & Ziedonis, R. H. (2001). The Patent Paradox Revisited: An Empirical Study of Patenting in the U.S. Semiconductor Industry, 1979-1995, *The RAND Journal of Economics* 32(1), 101-128.
- Hall, B. H. (2007). Patents and Patent Policy, *Oxford Review of Economic Policy* 23(4), 568-587.
- He, Z-L., Lim, K., Wong, P-K., (2006). Entry and competitive dynamics in the mobile telecommunications market. *Research Policy* 35, 1147-1165.
- Hedge, D., & Sampat, B. (2008). Examiner citations, applicant citations, and the private value of patents, *Economics Letters* 105(3), 287-289.
- Hui, Y. (2013). From Self-Innovation to International Standardization: A Case Study of TD-SCDMA in China, *Seoul Journal of Economics* 26(1), 113-146.
- Jaffe, A. B., Trajtenberg, M. & Henderson, R. (1993). Geographic localization of knowledge spillovers as evidenced by patent citations, *Quarterly Journal of Economics* 108, 577-598.
- Jaffe, A. B. (2000). The U.S. patent system in transition: policy innovation and the innovation process, *Research Policy* 29, 531-557.
- Jaffe, A. B., Trajtenberg, M. & Henderson, R. (1993). Geographic localization of knowledge spillovers as evidenced by patent citations, *Quarterly Journal of Economics* 108, 577-598.

- Jaffe, A. B., Trajtenberg, M., Fogarty, M.S., (2000). Knowledge spillovers and patent citations: Evidence from a survey of Inventors. *The American Economic Review* 90(2), 215-218.
- Jaffe, A. B., & Trajtenberg, M. (Eds.). (2002). *Patents, Citations & Innovations: A Window on the Knowledge Economy*. MIT Press.
- Jho, W. (2007). Global political economy of technology standardization: A case of the Korean mobile telecommunications market, *Telecommunications Policy* 31, 124-138.
- JISC (Japan Industrial Standards Committee). (2009). *Research on relationship and problem of standardization and technology development in the field of cutting-edge technology*. (In Japanese) Available at: [http://www.jisc.go.jp/policy/kenkyuukai/ipr/ipr\\_houkoku.html](http://www.jisc.go.jp/policy/kenkyuukai/ipr/ipr_houkoku.html)  
Original document: 日本工業標準委員会(2009).  
先端技術分野における技術開発と標準化の関係・問題に関する調査報告書
- Jones, B. F. (2009). The Burden of Knowledge and the “Death of the Renaissance Man”: Is Innovation Getting Harder?, *Review of Economic Studies* 76(1), 283-317.
- Kang, B., & Motohashi, K. (2012). Determinants of Essential Intellectual Property Rights for Wireless Communication Standard: Manufacturing firms vs. non-manufacturing patentees, RIETI Discussion Paper Series 12-E-042.
- Kang, B., & Bekkers, R. (2013). Just-in-time inventions and the development of standards: How firms use opportunistic strategies to obtain standard-essential patents (SEPs), Eindhoven Center for Innovation Studies (ECIS): Working paper No: 13-01.
- Kang, B., Dong, H., & Motohashi, K., (2013b). Asian Rise in ICT Global Standardization: An Empirical Analysis on Chinese and Korean Companies in Mobile Communications Standardization, 10th ASIALICS Conference: The Roles of Public Research Institutes and Universities in Asia’s Innovation Systems, Tokyo, Japan, 20-21 September 2013

- Karki, M.M.S., (1997). Patent citation analysis: A policy analysis tool, *World Patent Information* 19(4), 269-272.
- Keller, W. (1996). Absorptive capacity: On the creation and acquisition of technology in development, *Journal of Development Economics* 49, 199-227.
- Kenny, M., Breznitz, D., & Murphree, M. (2013). Coming Back Home after the Sun Rises: Returnee Entrepreneurs and Growth of High Tech Industries, *Research Policy* 42, 391-407.
- Kobayashi, B. H., & Wright, J. D. (2010). Intellectual property and standard setting. In ABA Handbook on the Antitrust Aspects of Standards Setting. American Bar Association.
- Kortum, S., & Lerner, J. (1999). What is behind the recent surge in patenting? *Research Policy* 28, 1-22.
- Kruskal, W. H., & Wallis, W. A. (1952). Use of ranks in one-criterion variance analysis. *Journal of the American Statistical Association* 47(260), 583-621.
- Lakoff, S., (2008). Upstart startup: constructed advantage and the example of Qualcomm. *Technovation* 28, 831-837.
- Larson J. F. (1995). *The telecommunications revolution in Korea*, Oxford University Press.
- Layne-Farrar, A., (2011). Innovative or indefensible? An empirical assessment of patenting within standard setting. *International Journal of IT Standards and Standardization Research* 9, Issue 2, 1-18.
- Lee, H., & Han, S.-Y. (2002). The Evolution of the National Innovation System in the Korean Mobile Telecommunication Industry, *Communications & Strategies* 48, 161-186.
- Lee, K., & Lim, C. (2001). Technological regimes, catching-up and leapfrogging:

- findings from the Korean industries, *Research Policy* 30, 459-483.
- Leiponen, A., (2006). National Styles in the Setting of Global Standards: The Relationship between Firms' Standardization Strategies and National Origin, in Zysman, J., Newman, A. (Eds), *How Revolutionary was the Digital Revolution? National Responses, Market Transitions, and Global Technology in the Digital Era*, Stanford University Press, 350-372.
- Leiponen, A.E., (2008). Competing through cooperation: Standard-setting in wireless telecommunications. *Management Science* 54, Issue 11, 1904-1919.
- Lemley, M. A. (2002). Intellectual property rights and standard-setting organizations. *California Law Review*, 90(6), 1889-1980.
- Lemley, M. A., & Shapiro, C. (2007). Patent holdup and royalty stacking. *Texas Law Review*, 85, 1991-2049.
- Lerner, J. (2002). 150 Years of Patent Protection, *The American Economic Review* 92(2), 221-225.
- Lin, B.-W., Chen, C.-J., & Wu, H.-L. (2006). Patent Portfolio Diversity, Technology Strategy, and Firm Value, *IEEE Transactions on Engineering Management* 53(1), 17-26.
- Liu, X., & Dalum, B. (2009). Path-following or leapfrogging in catching-up: The case of the Chinese telecommunications equipment industry. Presented at 'Wireless VITAE 2009: 1st International Conference on Wireless Communication, Vehicular Technology, Information Theory and Aerospace & Electronic Systems'.
- Machlup, F., & Penrose, E. (1950). The Patent Controversy in the Nineteenth century, *The Journal of Economic History* Vol. 10(1), 1-29.
- Malerba, F., & Nelson, R. R. (2012). *Economic Development as a Learning Process: Variation Across Sectoral Systems*, Edward Elgar Publishing.

- Mann, H. B., & Whitney, D. R. (1947). On a Test of Whether one of Two Random Variables is Stochastically Larger than the Other. *The Annals of Mathematical Statistics* 18(1), 50-60.
- Martinelli, A. (2011). An emerging paradigm or just another trajectory? Understanding the nature of technological changes using engineering heuristics in the telecommunications switching industry. *Research Policy*, 41(2), 414-429.
- Michel, J., & Bettels, B., (2001). Patent citation analysis: A close look at the basic input data from patent search report. *Scientometrics* 51, No.1, 185-201.
- Mock, D., (2005). *The Qualcomm Equation*, American Management Association, New York.
- Moser, P. (2005). How Do Patent Laws Influence Innovation? Evidence From Nineteenth-Century World's Fairs, *The American Economic Review* 95(4), 1214-1236.
- Motohashi, K., (2008). Assessment of technological capability in science industry linkage in China by patent database, *World Patent Information* 30, 225-232.
- Mowery, D. C., & Oxley, J. E. (1995). Inward technology transfer and competitiveness: the role of national innovation systems, *Cambridge Journal of Economics* 19, 67-93.
- Mu, Q., & Lee, K. (2005). Knowledge diffusion, market segmentation and technological catch-up: The case of the telecommunication industry in China, *Research Policy* 34(6), 759-783.
- Murphree, M., & Breznitz, D. (2013). Innovation in China: Fragmentation, Structured Uncertainty, and Technology Standards, *Cardozo Law Review de novo*, 196-213.
- Nagaoka, S., Motohashi, K., & Goto, A. (2010). Patent Statistics as an Innovation Indicator, in Hall, B.H, Rosenberg, N., (Eds), *Handbook of the Economics of*

- Innovation*, Volume 2, Academic Press, 1083-1128.
- Narin, F., & Noma, E. (1985). Is technology becoming science?, *Scientometrics* 7, 369-381.
- Narin, F., & Noma, E. (1987). Patents as indicators of corporate technological strength, *Research policy* 16, 143-155.
- Narin, F., & Breitzman, A. (1995). Inventive productivity, *Research Policy* 24, 507-519.
- Narin, F., Hamilton, K. S., & Olivastro, D. (1997). The increasing linkage between U.S. technology and public science, *Research Policy* 26, 317-330.
- Nelson, A. J. (2009). Measuring knowledge spillovers: What patents, licenses and publications reveal about innovation diffusion, *Research Policy* 38, 994-1005.
- Noyes, J. (1983). The QWERTY keyboard: a review, *International Journal of Man-Machine Studies* 18, 265-281.
- Omachi, M. (2004). Emergence of Essential Patents in Technical Standards: Implications of the Continuation and Divisional Application Systems and the Written Description Requirement. IIR Working Paper WP#05-02. Retrieved from <http://hermes-ir.lib.hit-u.ac.jp/rs/bitstream/10086/15993/1/070iirWP05-02.pdf>
- Patel, P., & Pavitt, K. (1997). The technological competencies of the world's largest firms: Complex and path-dependent, but not much variety, *Research policy* 26, 141-156.
- Polanyi, M. (1944). Patent Reform, *The Review of Economic Studies* 11(2), 61-76.
- Prahalad, C. K., & Hamel, G. (1990). The core competence of the corporation. *Harvard Business Review* 68(3), 79-91.

- Qian, Y. (2007). Do National Patent Laws Stimulate Domestic Innovation in a Global Patenting Environment? A Cross-Country Analysis of Pharmaceutical Patent Protection, 1978-2002, *The Review of Economics and Statistics* 89(3), 436-453.
- Reitzig, M., Henkel, J., & Heath, C. H. (2007). On sharks, trolls, and their patent prey - unrealistic damage awards and firms' strategies of 'being infringed'. *Research Policy* 36, 134-154.
- Rysman, M., Simcoe, T., & Heath, C., (2008). Patents and the performance of voluntary standard-setting organizations. *Management Science* 54, 1920–1934.
- Sakakibara, M., & Branstetter, L. (2001) Do stronger patents induce more innovation? Evidence from the 1988 Japanese patent law reforms, *Rand Journal of Economics* 32(1), 77-100.
- Sakata, I., & Sasaki, H. (2013). Scientific Catch-Up in Asian Economies: A Case Study for Solar Cell, *Natural Resources* 4(1A), 134-141.
- Shapiro, C., & Varian, H. R. (1999). *Information Rules: a strategic guide to the network economy*, Cambridge, Harvard University Press.
- Shapiro, C. (2001). Navigating the patent ticket: cross licenses, patent pools, and standard setting. In A. Jaffe, J. Lerner, & S. Stern, (Eds.). *Innovation Policy and the Economy* Vol.I, MIT Press, Cambridge.
- Shapiro, C. (2004). PATENT SYSTEM REFORM: ECONOMIC ANALYSIS AND CRITIQUE, *Berkeley Technology Law Journal* 19(3), 1017-1047.
- Simcoe, T. S., Graham, S. J. H., & Feldman, M. P. (2009). Competing on Standards? Entrepreneurship, Intellectual Property, and Platform Technologies, *Journal of Economics & Management Strategy* 18(3), 775–816.
- Son, W., 2013. *Samsung, History of persistent innovation - All of winning innovation*, Korea.com (In Korean)

- Tan, Z. A. (2002). Product cycle theory and telecommunications industry - foreign direct investment, government policy, and indigenous manufacturing in China, *Telecommunications Policy* 26(1), 17-30.
- Tassy, G. (2000). Standardization in technology-based markets, *Research Policy* 29, 587-602.
- Teece, D. J. (1992). Competition, cooperation, and innovation: Organizational arrangements for regimes of rapid technological process, *Journal of Economic Behavior & Organization* 18 (1), 1-25.
- Thompson, M. A., & Rushing, F. W. (1996). An Empirical Analysis of the Impact of Patent Protection on Economic Growth, *Journal of Economic Development* 21(2), 61-77.
- Trainer, M. (2007). The role of patents in establishing global telecommunications, *World Patent Information* 29, 352-362.
- Trajtenberg, M. (1990). A Penny for your Quotes: Patent Citations and the Value of Innovations. *RAND Journal of Economics*, 21, 172-187.
- Trajtenberg, M., Henderson, R., & Jaffe, A. (1997). University Versus Corporate Patents: A Window on The Basicness Of Invention. *Economics of Innovation and New Technology* 5(1), 19-50.
- Verspagen, B. (2007). Mapping technological trajectories as patent citation networks: a study on the history of fuel cell research. *Advances in Complex Systems* 10, 93-115.
- Veugelers, R. (1997) Internal R&D expenditures and external technology sourcing, *Research Policy* 26(3), 303-315.
- Wajima, K., Inuzuka, A., & Watanabe, T. (2010). Empirical Study on Essential Patents in DVD and MPEG Standards Patent Pools, IAM Discussion Paper Series #16.



- Webb, C., Dernis, H., Harhoff, D., & Hoisl, K. (2005). Analysing European and International Patent Citations: A Set of EPO Patent Database Building Blocks, *OECD Science, Technology and Industry Working Papers*, 2005/09, OECD Publishing.
- Willingmyre, G. T. (2012). Cooperation between Patent Offices and Standards Developing Organizations. Washington, DC: National Academies of Science. Retrieved from [http://sites.nationalacademies.org/xpeditio/groups/pgasite/documents/webpage/pga\\_072350.pdf](http://sites.nationalacademies.org/xpeditio/groups/pgasite/documents/webpage/pga_072350.pdf)
- Wuchty, S., Jones, B., & Uzzi, B. (2007). The Increasing Dominance of Teams in the Production of Knowledge, *Science* 316, 1036-1039.
- Yoo, Y., Lyytinen, K., & Yang, H. (2005). The role of standards in innovation and diffusion of broadband mobile services: The case of South Korea, *Journal of Strategic Information Systems* 14, 323-353.
- Yu, J., & Tan, K. H. (2005). The evolution of China's mobile telecommunications industry: past, present and future, *International Journal of Mobile Communications* 3(2), 114-126.

## Acknowledgement

First of all, I would like to thank God for his guide.

I am highly indebted to Professor Kazuyuki Motohashi. I am very much honored to study under his supervision. I appreciate all his contributions of time, ideas, and funds. He created an environment in which I could fully commit to my work, and also offered me various experiences. Most of all, without his supervision, I would have not been able to reach who I am now.

Special thanks go to Professor Rudi Bekkers. His professionalism has also inspired me. My stay in the Netherlands has remained so much special. Working with him was a great honor and so much joy for me. Co-work with him has become one of the cornerstones for the next.

I am grateful to Motohashi Laboratory members. Especially, I enjoyed discussions with Dr. Takanori Tomozawa (Now with Ministry of Economy, Trade and Industry), Dr. Dong Huo, Mr. Suchit Pongnumkul, Miss Kuniko Matsumoto (Now with SIGMAXYZ Inc.), Mr. Jianwei Dang, Mr. Hideshi Aoki (Now with Panasonic Corporation), Mr. Toshitaka Tomioka (Now with A.T. Kearney), Mr. Seokbeom Kwon, Mr. Teppei Toda (Now with A.T. Kearney), and Prof. Yeong-Wha Sawng (Now with Konkuk University). I wish all the best for them.

I also express my gratitude to friends. This research work couldn't have been completed without their encouragement and help. It is just impossible to pen down every name in this paper.

Finally, I appreciate love, prayer, and support that my family gave to me. Especially, my wife, Alexandra, has been always there for me every moment and she has sacrificed opportunities for my study. Just saying 'thank you' is too little to express my indebtedness to her.

Byeongwoo Kang  
The University of Tokyo  
March 2014

## About Author

Byeongwoo Kang was born in Daegu, Korea, in 1982. He received his B.S. and M.S. degrees in Communications Engineering from Tohoku University, in 2006 and 2008.

Between April 2008 and May 2011, he was with Mobile Communication Technology Research Laboratory (Now Advanced Communication Technology R&D Laboratory), LG Electronics and conducted research to standardize next generation standards for mobile wireless communications. Some of his inventions are used in 3GPP LTE-Advanced and IEEE 802.11ac. The work experience at LG Electronics let him realize important issues about management of technology and intellectual property rights in standards.

In April 2011, after leaving LG Electronics, he started his doctoral study at Department of Technology Management for Innovation, The University of Tokyo. Since September 2011, he has been involved in projects as a research assistant at Research Institute of Economy, Trade and Industry (RIETI), Japan. His research interests include standardization and intellectual property rights, technology commercialization, markets for technology, collaborations between actors of national innovation systems as well as technologies such as signal processing and mobile wireless communications technologies.